



Commercial Application of HTS Power Cables in KEPCO, Korea



Dec. 4, 2019

Chulhyu LEE
Korea Electric Power Corp.



Contents

- ▶ 1. What did we do to promote the application of HTS technology in KEPCO?
- ▶ 2. What is the benefit of the world's 1st commercial project of 23 kV HTS power cable; Shingal Project ?
- ▶ 3. What do we have as a next step to keep the HTS cable technology moving forward ?
- ▶ 4. What is the plan for the further application of distribution HTS cables for an urban power supply ?



1. What did we do to promote the application of HTS technology?

- ▶ We have wonderful technology in our hands; high possibilities to apply HTS cables to power system
- ▶ However, it's too premature to create its own market

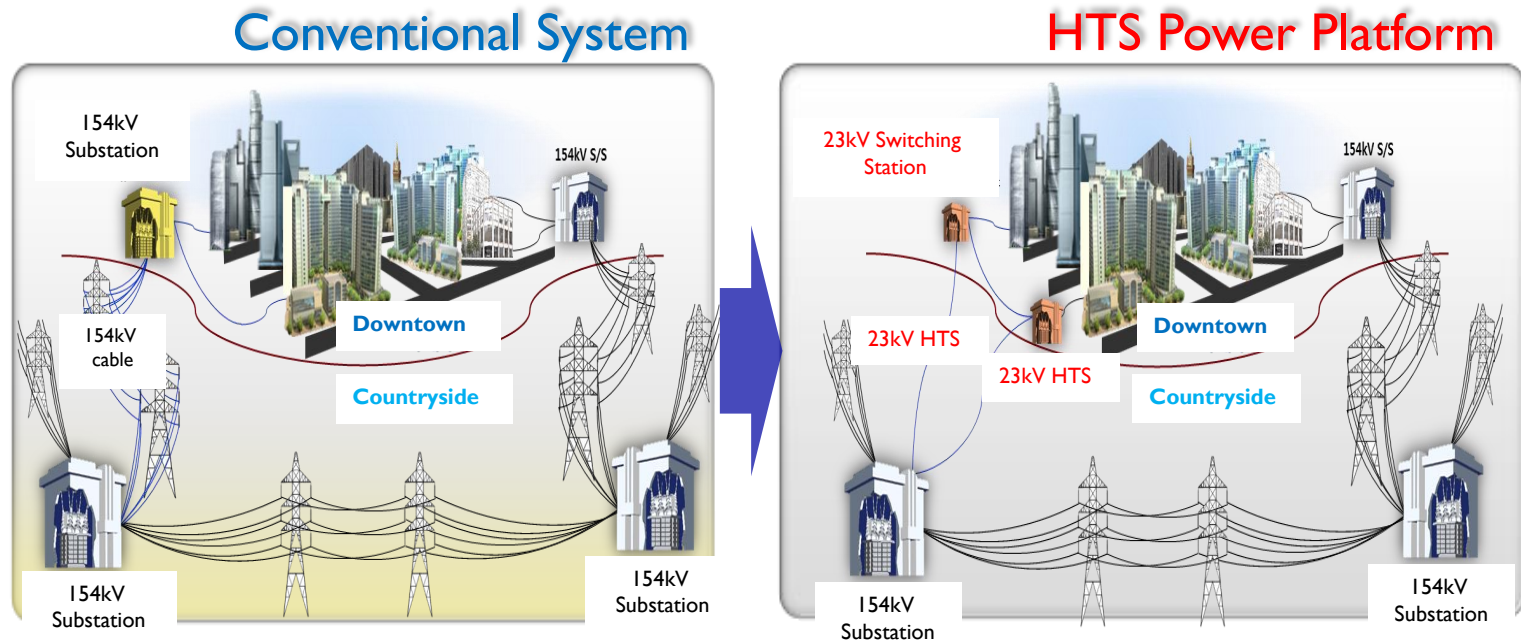

1. What did we do to promote the application of HTS technology?

- ▶ There have been much debates on which party should come first between utilities and manufacturers.

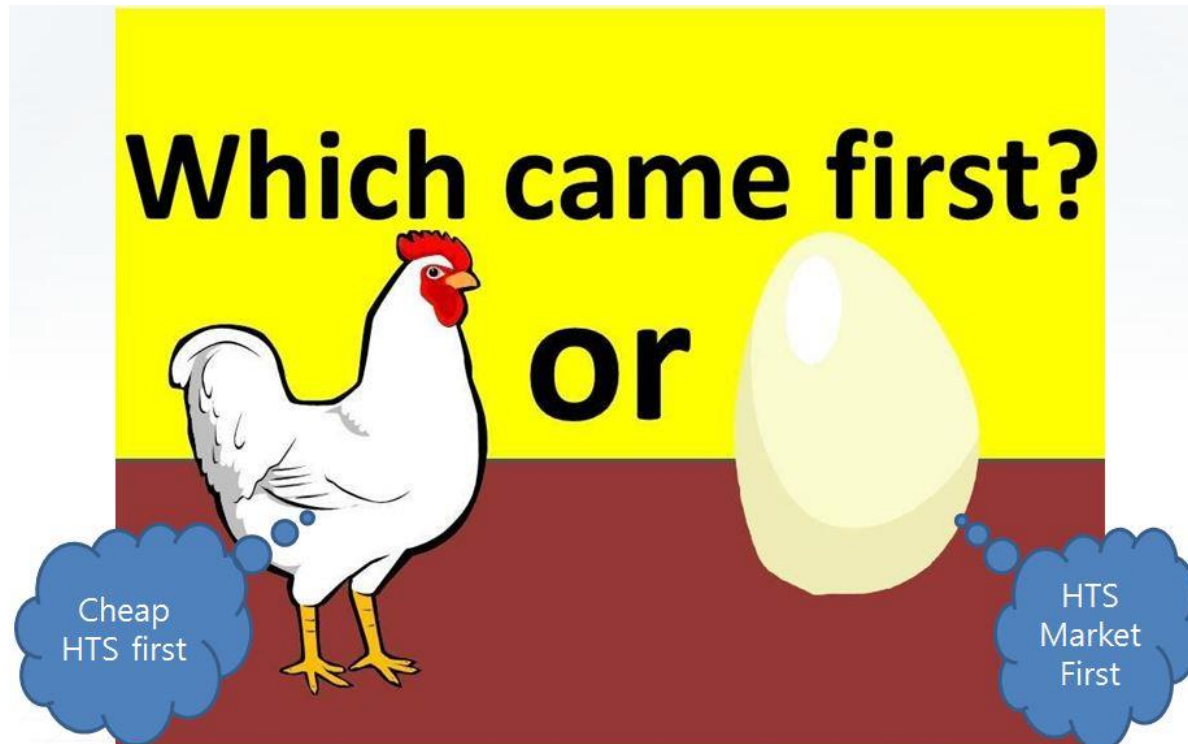

1. What did we do to promote the application of HTS technology?

- ▶ **KEPCO declared its leadership** with the support of high executive levels on the business launching ceremony (Apr. 2016)
 - ▶ “We choose to go to the HTS business” by KEPCO CEO
- ▶ That event successfully triggered interests and vision of KEPCO engineers as well as industry



2. What is the benefit of 23 kV HTS power cable application ; “Shingal Project” ?

- ▶ Shingal Project is to connect two 154 kV substations with a 23 kV HTS cable over a distance of 1 km
- ▶ The 23 kV HTS cable connection has the effect of **sharing the supply capability** between the two substations,
 - ▶ **Emergency supply** through the HTS cable became possible during a blackout of the 154 kV substation
- ▶ **S. Korea is the first country** in the world to deploy a commercial HTS AC cable (July 2019, IEA)



2. What is the benefit of 23 kV HTS power cable application ; “Shingal Project” ?

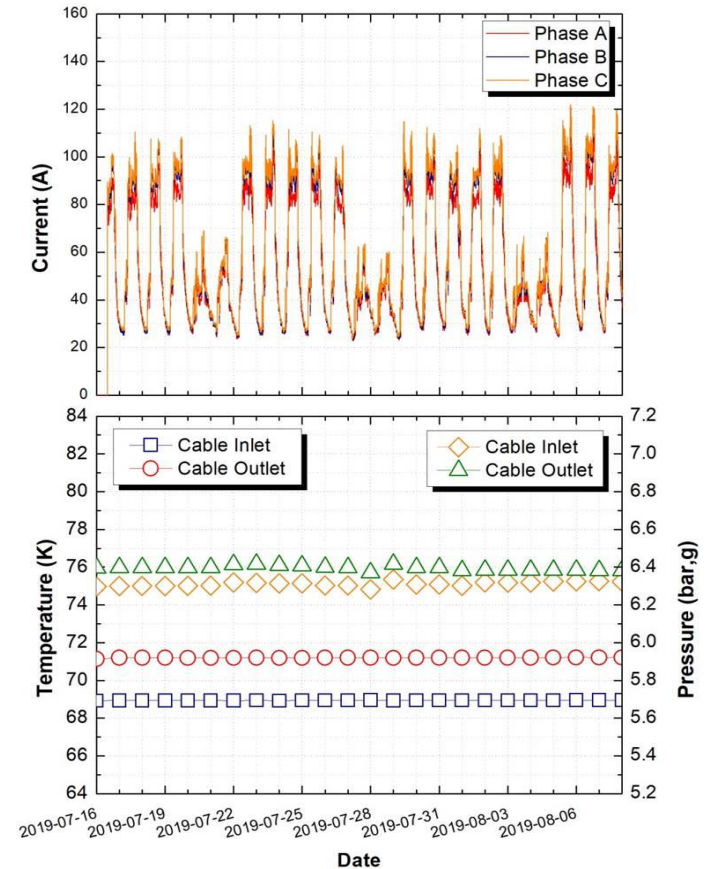
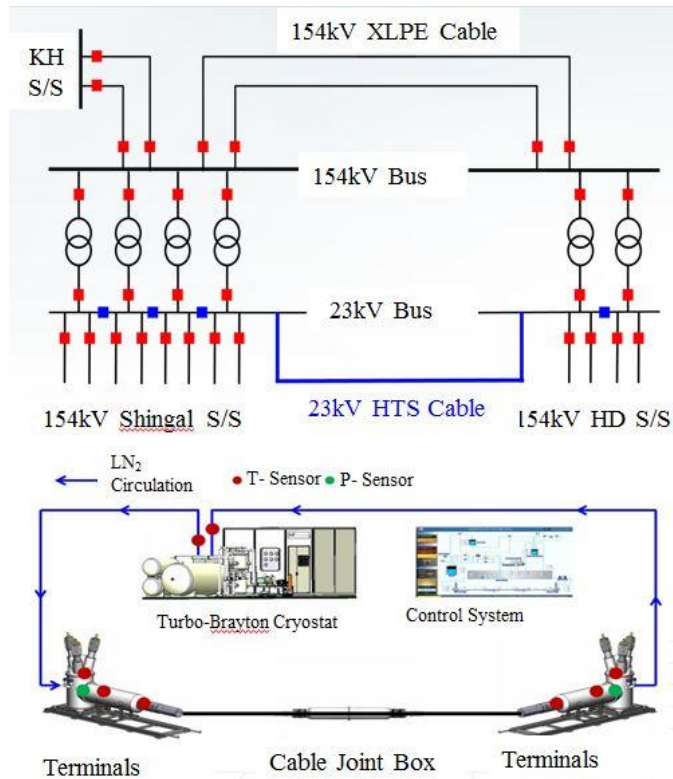

2. What is the benefit of 23 kV HTS power cable application ; “Shingal Project” ?

- ▶ In terms of Economy,
 - ▶ Total investment cost : \$14.9 million
 - ▶ HTS cable(\$7.2M), cooling system(\$6.3M), and commons(\$1.4M)
 - ▶ Cooling system consumes almost the same electricity as much as power loss reduction of HTS cables
- ▶ In terms of Non-Energy benefit
 - ▶ Expected to enhance the load supply capability and reliability
 - ▶ On the Shingal Project completion ceremony, dated Nov. 5, 2019, the word “Superconductor” was at the top of the **NAVER search word** (NAVER is Korea’s largest portal site like Google), the stock price of LS cable jumped by up to 8 % as well.



3. What do we have as a next step to keep HTS technology moving forward?

- ▶ **The 2nd commercial project of HTS power cables** will be the Onsu Project, to connect two 154 kV substations with one circuit of 154 kV HTS cables.

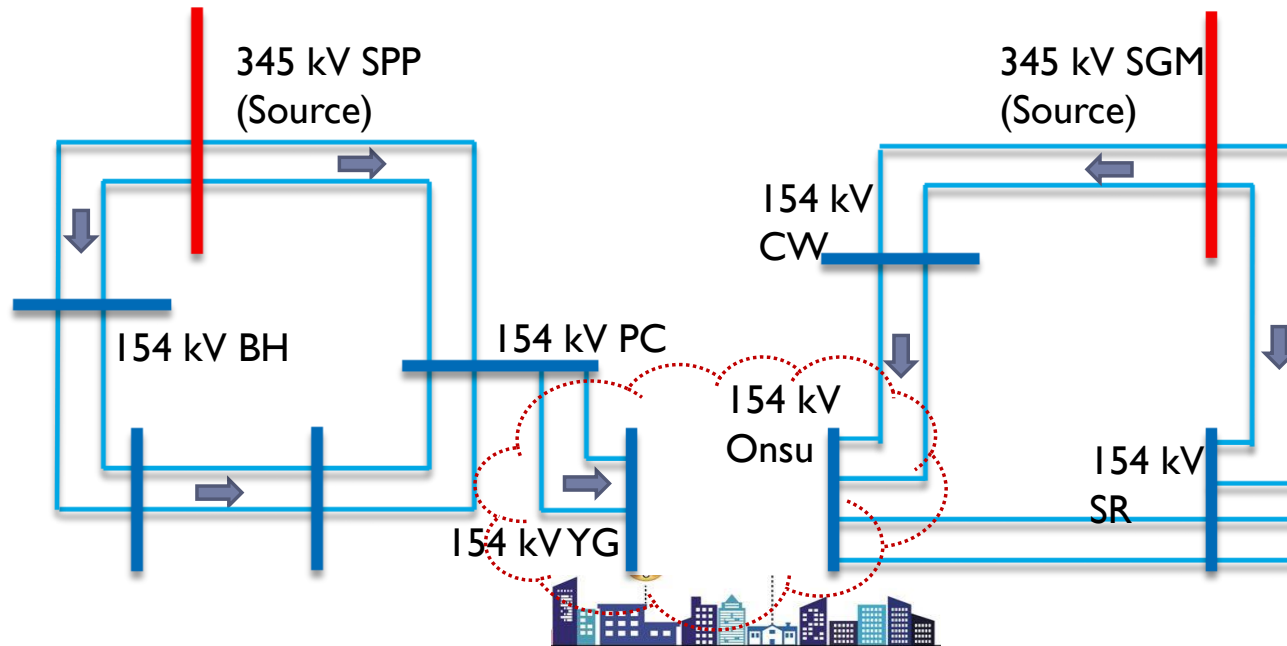

Peak Demand 149 MW in 2019

3. What do we have as a next step to keep HTS technology moving forward?

- ▶ Under a conventional approach, two circuits of transmission cables with the rating of 400 MVA necessary; however, cable tunnel construction is inevitable
- ▶ **Using HTS cable approach**, one circuits of 154 kV HTS cable installed in the conduit is sufficient, which will be **the same investment cost** as conventional approach, and will **reduce the construction duration** from 36 months to 12 months

Cable tunnel with the diameter of 2.4 m at the depth of 50m below GL (Shield TBM)

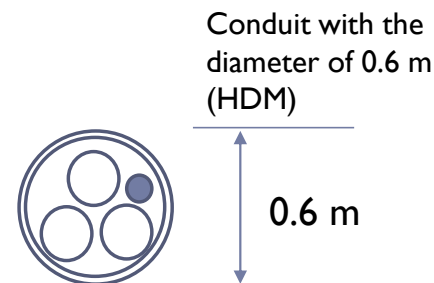
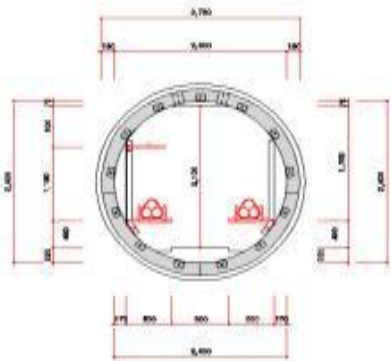

3. What do we have as a next step to keep HTS technology moving forward?

2nd commercial project of 154 kV HTS cables between the Onsu and YG substations

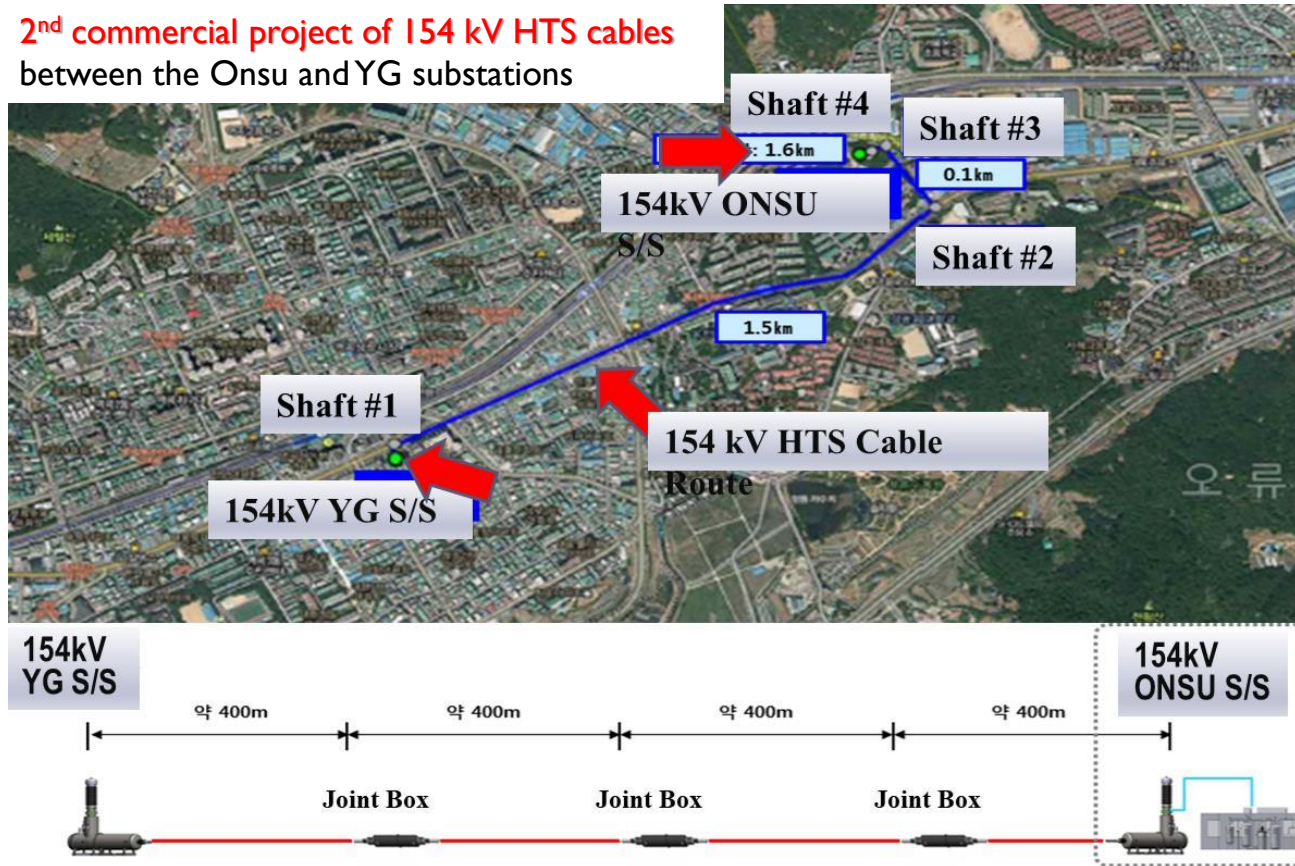

3. What do we have as a next step to keep HTS technology moving forward?

Category	Item	Construction Cost (million USD)		Remarks
		XLPE * 2	HTS * 1	
Transmission Cable Construction	Equipments	1.87	24.1	
	Installation	0.84	2.0	
	Cable Tunnel	26.90	-	
	HDD Conduit	-	2.8	
	Sub Total	29.61	28.9	
Substation Construction	Equipment	1.20	0.60	GIS installation
	Installation	0.24	0.12	
	Sub total	1.44	0.72	50%
Total		31.05	29.62	Savings of 1.38

2nd commercial project of 154 kV HTS cables between the Onsu and YG substations

4. What is the plan for the further application of the 23 kV HTS cables?

- ▶ Challenges preventing massive adoption of HTS
 - ▶ **High cost of HTS wires & the short distance of HTS cooling**
 - ▶ Can we expect the learning curve of solar cell is applied to HTS ?

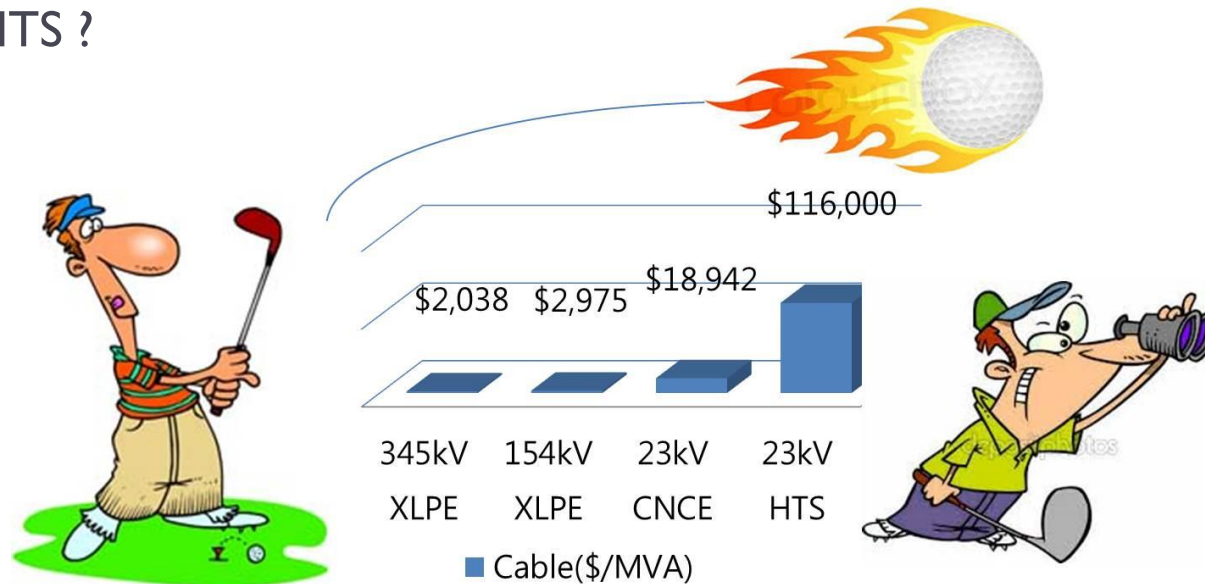

4. What is the plan for the further application of the 23 kV HTS cables?

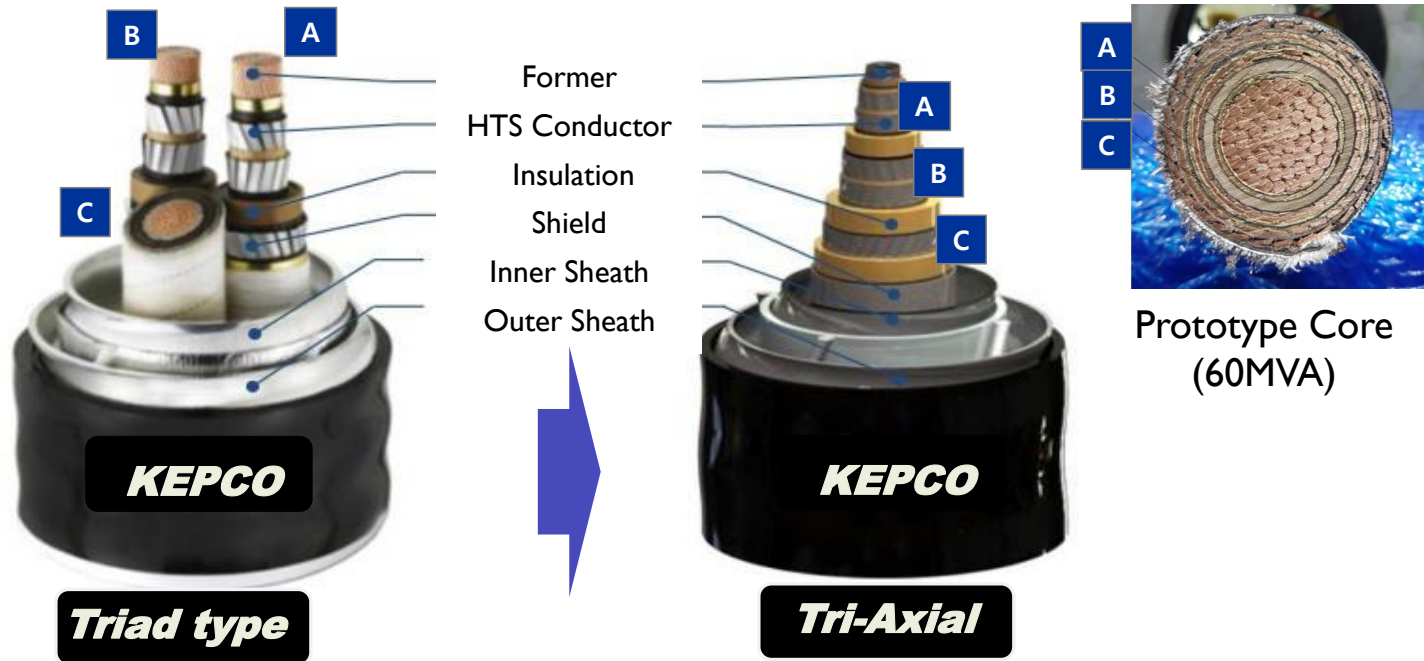

Capacity (MVA)	23 kV HTS Cable System (2 circuit, Reliability Criteria N-1)		
	1km (million USD)	2km	3km
120	2,490 → 1,800	4,190 → 3,040	6,130 → 4,270

4. What is the plan for the further application of the 23 kV HTS cables?

- ▶ **A 60 MVA 23 kV HTS Power Platform** will be demonstrated in an actual grid between the 154 kV Munsan and Sunyou substations

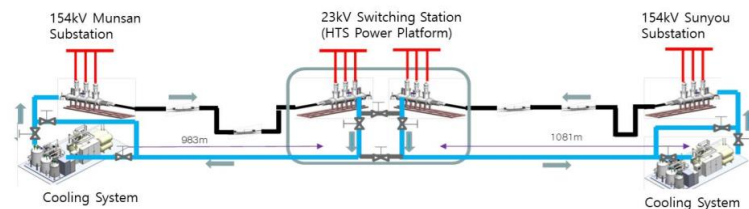
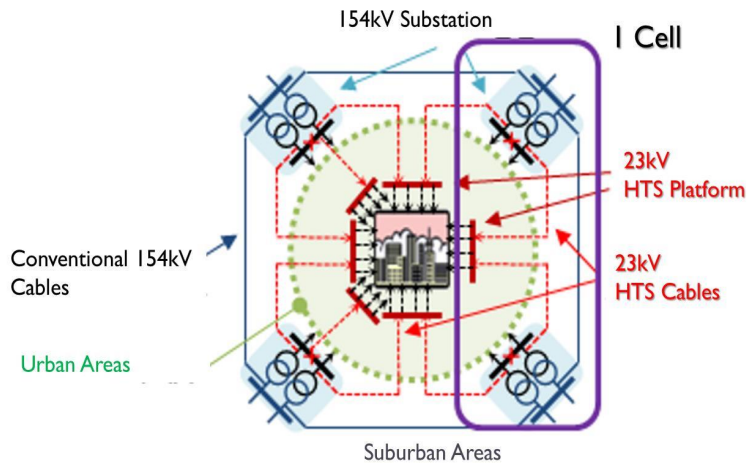

5. Conclusion

- ▶ Not long ago, an American film titled “Current war” was shown. DC of Edison vs AC of Tesla ➡ How about HTS DC cables?
- ▶ In the past, electricity wasn’t able to be stored. Not any more. ESS equipped with Li-battery ➡ How about the SMES?
- ▶ IT revolution has been taking place on the basis of semiconductor devices
- ▶ It’s time for **the superconducting society to lead the wave of paradigm change.**

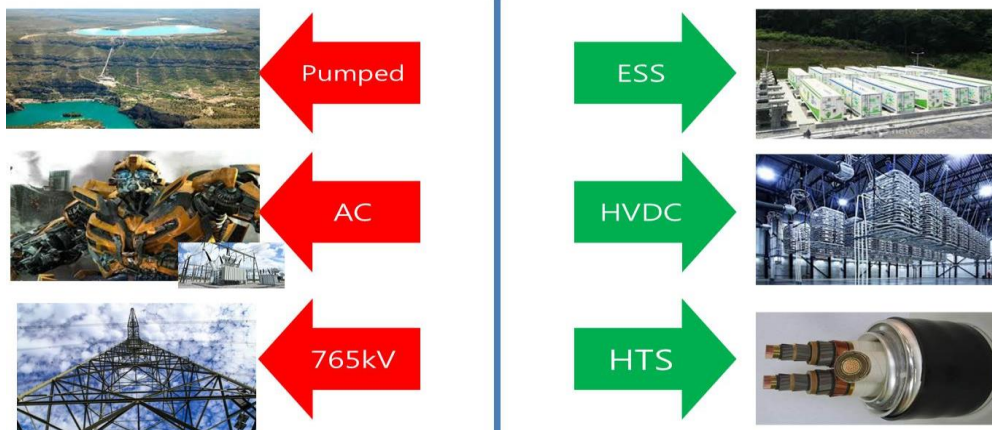



Thank you for your attention

chulhyu.lee@kepco.co.kr

