



Nexans is paving the way for a superconducting electric world

ARNAUD ALLAIS / JUNE 14, 2022



Content



- 1 — HTS SOLUTIONS FOR GRIDS
- 2 — 20 YEARS OF HTS SYSTEMS IN THE GRID
- 3 — THE NEXT STEPS
- 4 — NEED FOR A NEW MODELING APPROACH

1

HTS Solutions for Grids

1.1/ Nexans HTS solutions

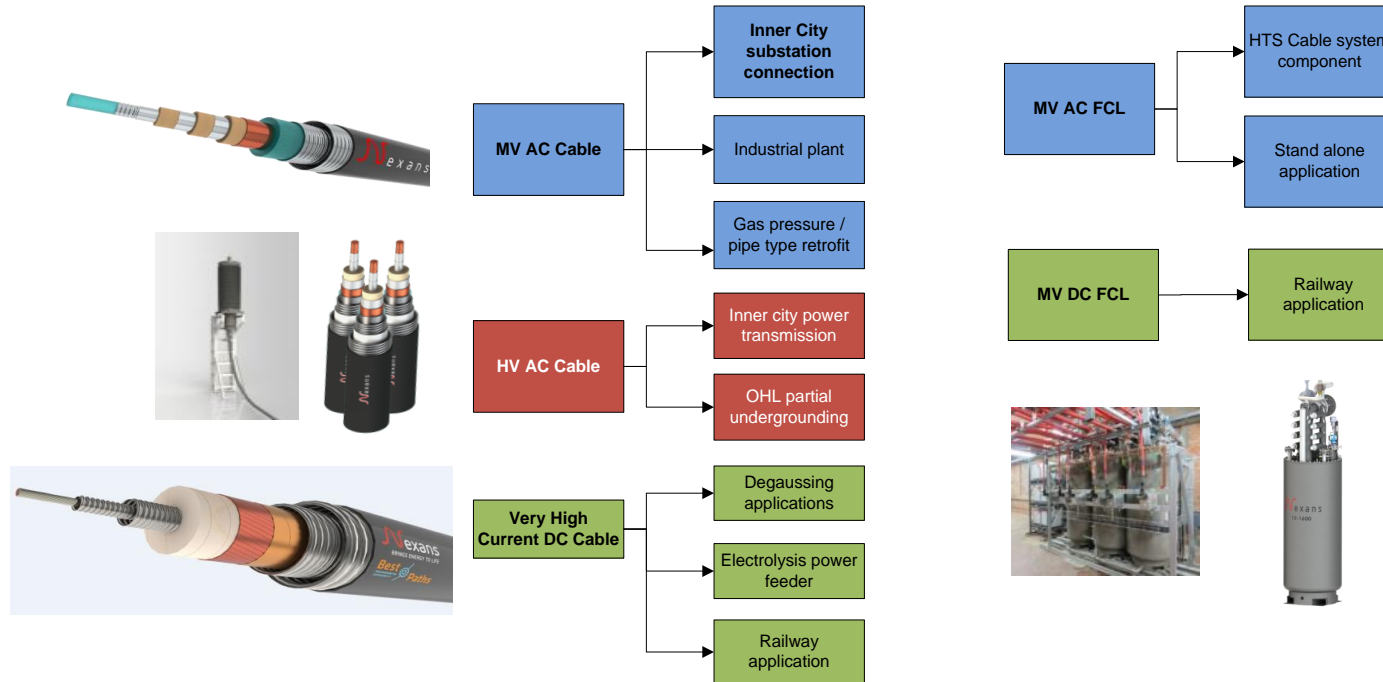

1.2 / HTS cable system components

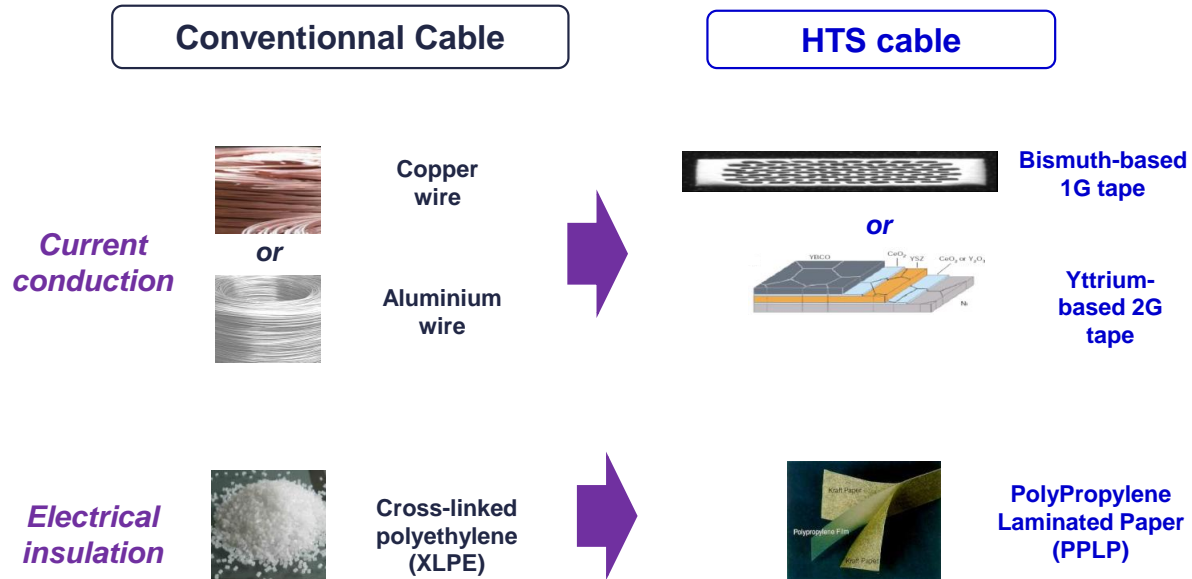

1.2 / HTS cable system components

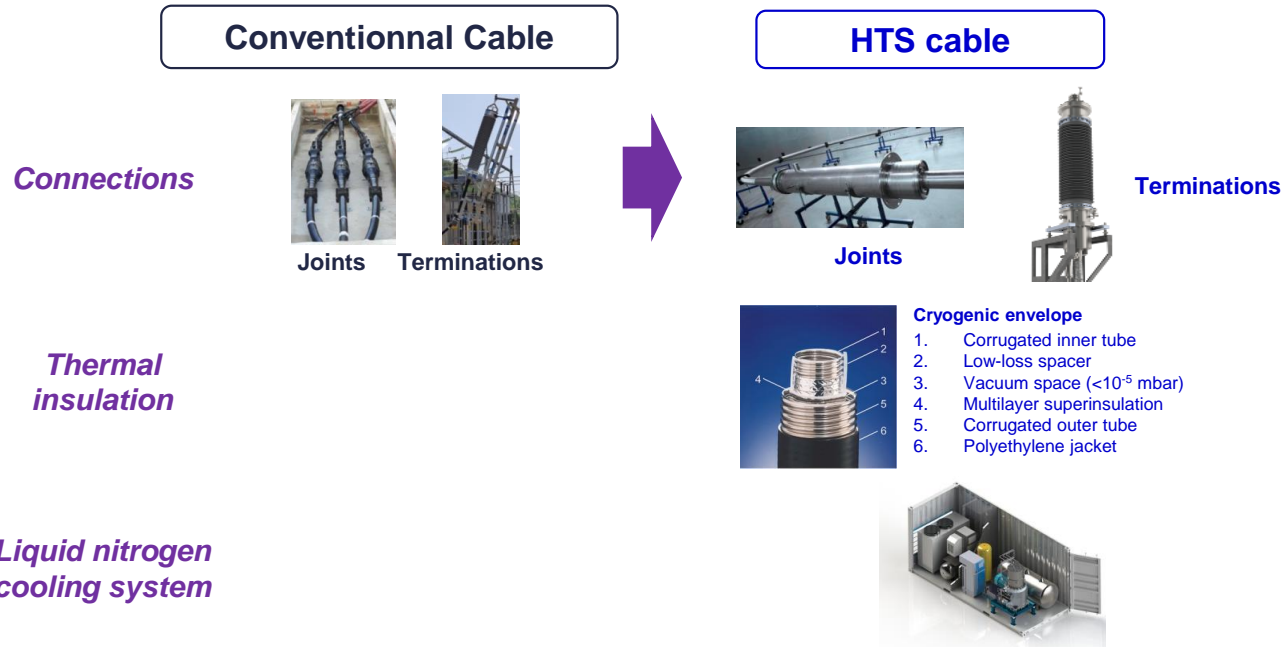

1.1 / 3-phase cable design for MVAC applications

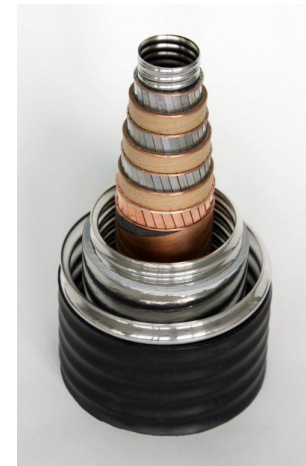
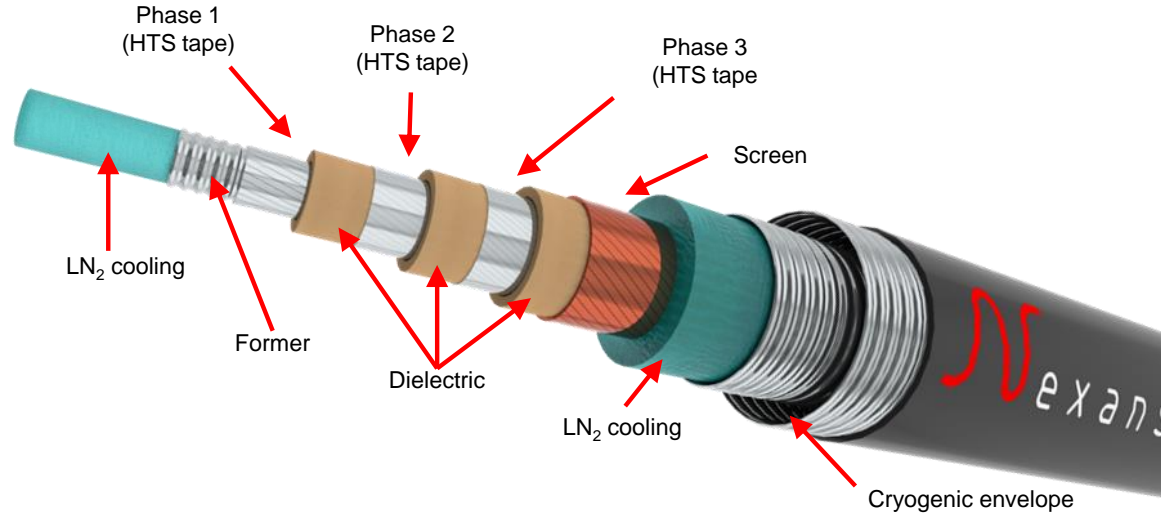

1.2 / Cable phase design for HVAC applications

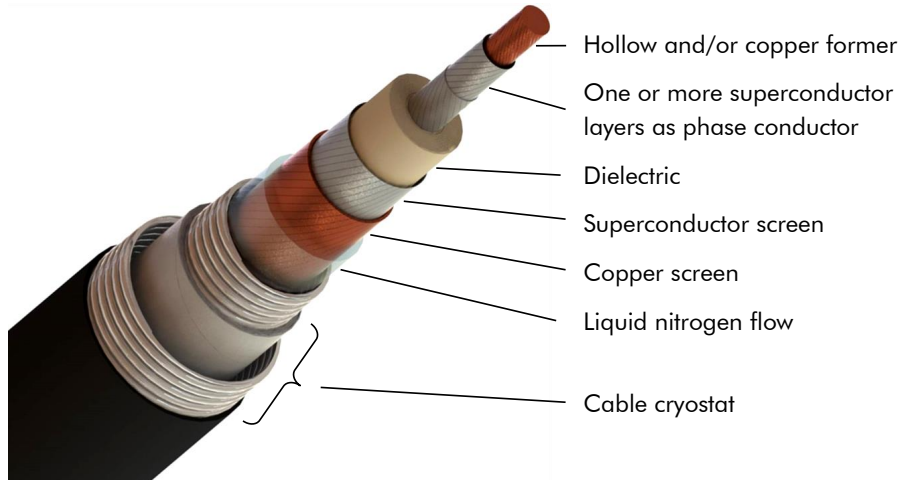

1.2 | HTS cables Technologies Readiness Levels

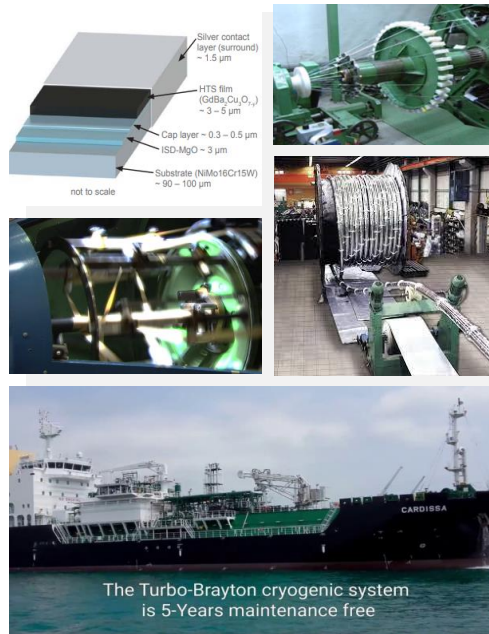

ALL BRICKS ARE INDUSTRIAL

- Production of superconducting tapes (thin film coating of metallic tapes) are strongly pushed by demands for fusion and land superconducting cables.
- All processes for cable core manufacturing are the same as for HV submarine conventional cables (tape stranding, paper or PPLP dielectric lapping – no limitation in length).
- Flexible cryostats are widely used for spatial (liquid oxygen and hydrogen) and energy markets (LNG, hydrogen). They have been manufactured for more than 40 years and can be continuously produced around the cable core.
- Cooling stations above 100 kW@ liquid nitrogen temperature are produced in series and currently installed on decks of LNG tankers

1.2 | HTS cable benefits – Compactness / Neutrality



NO ELECTROMAGNETIC FIELD

Without shielding
 $MB(I_3, 1-m, 1-m) = 26.871 \mu\text{tesla}$
 With shielding around duct
 $MBS(I_3, 1-m, 1-m) = 7.677 \mu\text{tesla}$

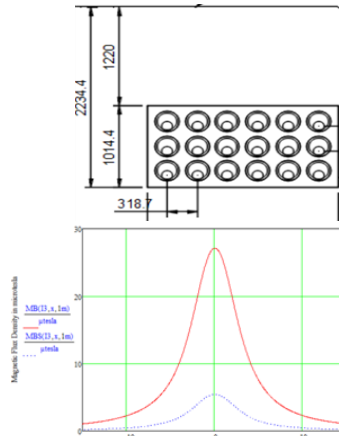

138 kV resistive cables

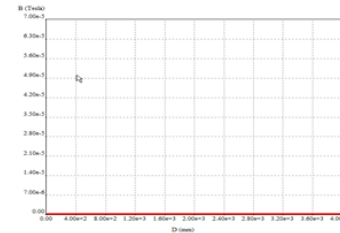
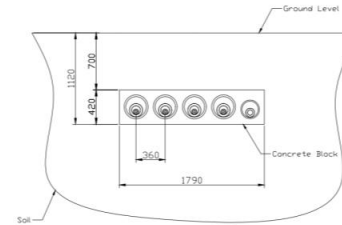

138 kV HTS cables

$B_{\max} = 0.0017 \mu\text{T}$

1.3 | HTS Resistive FCL - Unique Benefits



#01

INVISIBLE TO
THE GRID

#04

ALLOW OR
SIMPLIFY DISTRIBUTED
GENERATION

#02

REDUCE SHORT
CIRCUIT
CURRENTS

– lower rating equipment

#05

IMPROVE
SAFETY

#03

ENABLE GRID
COUPLING

#06

COMPATIBLE WITH
UNMANNED
OPERATIONS



©2022 Nexans

1.3 | HTS Resistive FCL - Characteristics



FAST

- Reacts in <math><2\text{msec}</math>
- Ensure voltage stability during fault

AUTOMATIC

- No external trigger necessary
- Self-recovery

WEAR-FREE

- Service only required to maintain cooling

UNMANNED OPERATION:

- No spare parts on site
- No action of operators required

PROTECTION COORDINATION:

- Does not impact existing protection

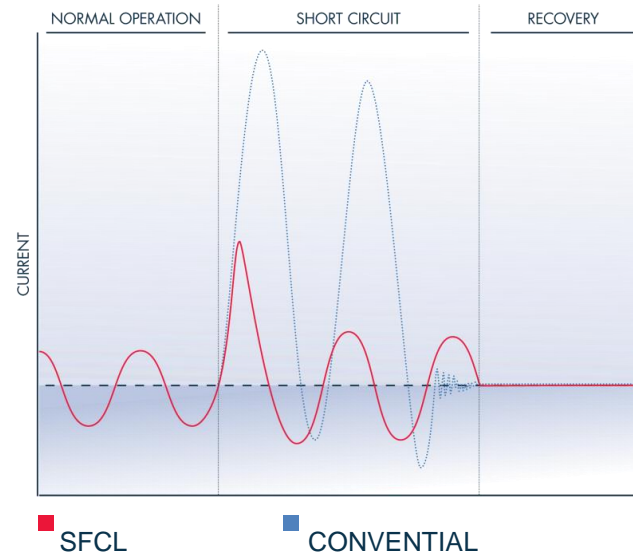

1.3 | HTS Resitive FCL - Assets Life Extension



DRASTIC LIMITATION OF HIGH FAULT CURRENTS DAMAGE TO:

- Breakers
- Transformers
- Grounding equipment
- Cables

BENEFITS

- Reduces or eliminates the need to upgrade circuit breakers or add series reactors
- Prevents equipment damage to ancillary equipment and the follow on replacement
- Eliminates need to reinforce buswork

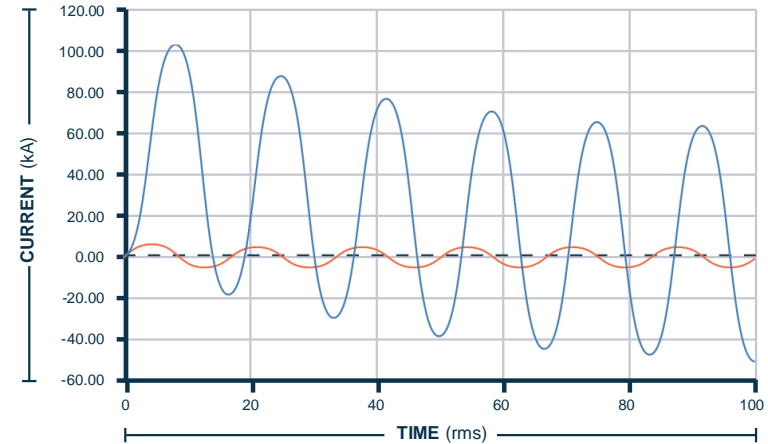

Prospective current and limited current for pphase A of the 1200A

Unit: Assumptions: fault current 40 kA (rms), X/R =16

— Prospective current - phase R

— limited current - phase R

©2022 Nexans

1.3 | HTS Resistive FCL ranges



- Medium voltage fault-current limiters (6 kV - 36 kV)
- AC (16.67 Hz - 60 Hz) or DC
- Currents in the range of a few hundred A to 5kA
- Different cooling options
- Limited current adjustable to customers' needs
- Operation monitoring
- Installation, commissioning and service

1.3 | HTS Resistive FCL - Design basics

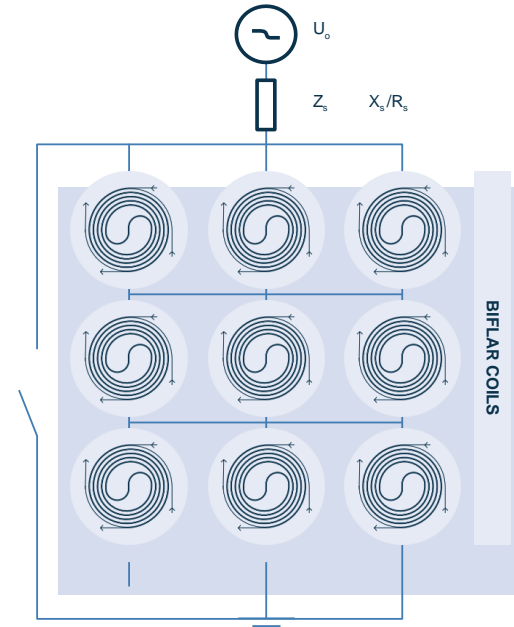
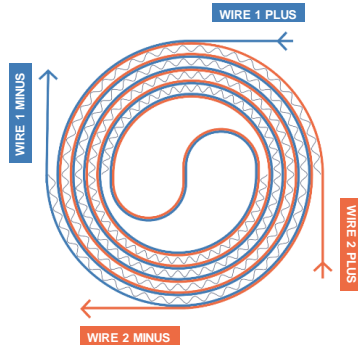

- The sFCL uses is made up of an array of standard “FCL Coils”
- Coils are arranged in a array
- # of Columns in parallel selected to achieve desired current rating
- # of Rows in series selected to achieve desired limiting resistance

2 | 20 years of HTS systems in the grid

Map of HTS cable projects in the world

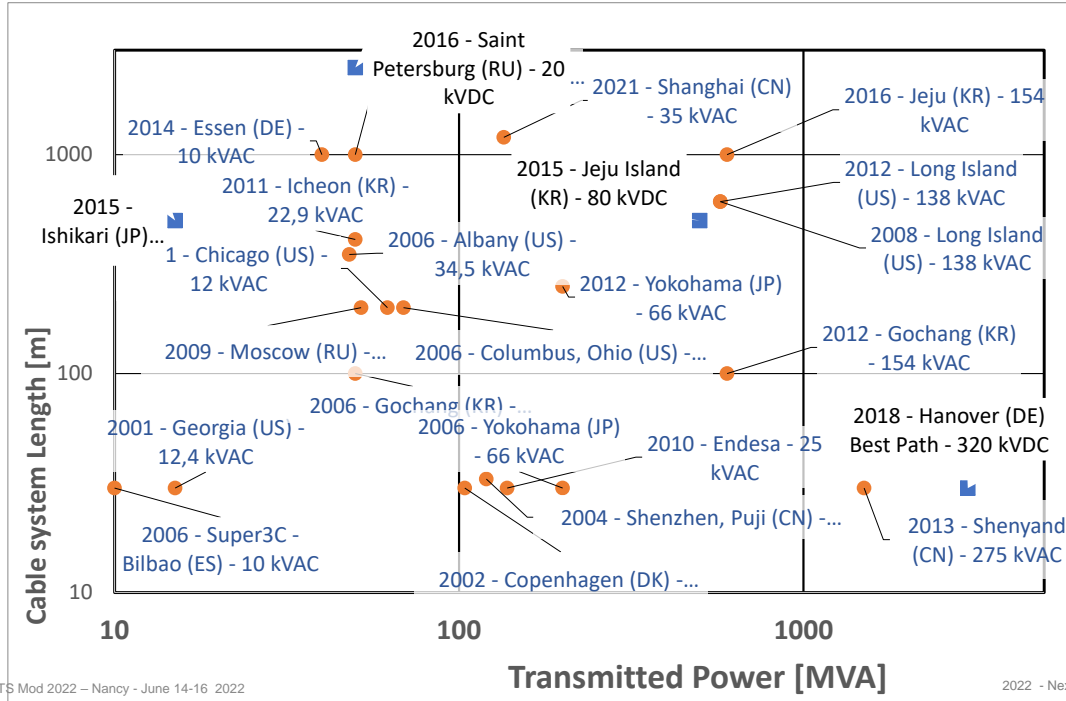

4 DC cables
 21 AC cables

From 2001 to 2021

Focus on Nexans HTS cable projects

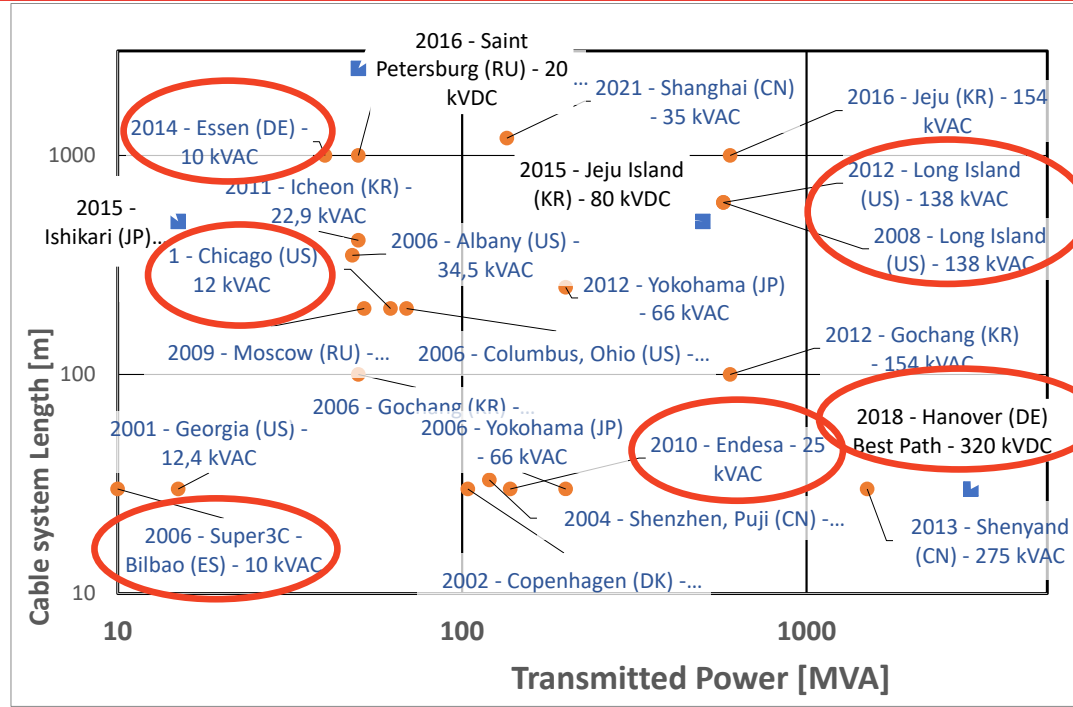

COMED - MVAC



- 200-meter 12 kV, 3 kA (62 MVA) HTS cable system
- Commissioned in ComEd substation during summer 2021
- Demonstrator preparing the connection of downtown Chicago substation through a high-capacity 5 km HTS loop at 12 kV

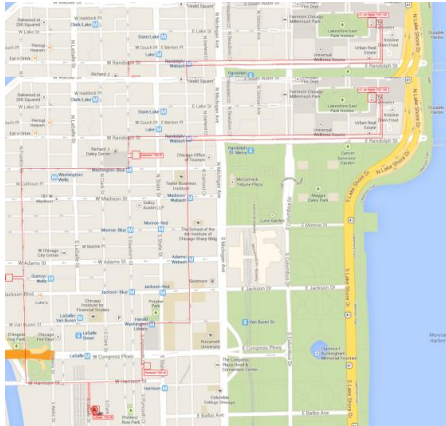

AMPACITY MVAC project



AMPACITY cable installation

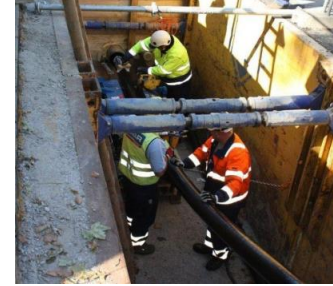

LIPA HVAC project in Long Island



- Cable connected to Long Island Power Authority Grid
- 600 m HTS cable system
 - 138 kV, 2,4 kA ~ 574 MVA
 - Specified fault current of 51 kA during 200 ms
- Cable pulled in HDPE pipe
- Worlds first HTS cable operating at transmission voltage level



European HVDC development project BestPaths



Length	30 m
Voltage	320 kV DC
Current	10 000 A
Power	3.2 GW



Cable core



Full cable



Test of 30 m cable system in Nexans laboratory

The production of 3 nuclear reactors can flow through this cable

Nexans HTS FCL in Europe

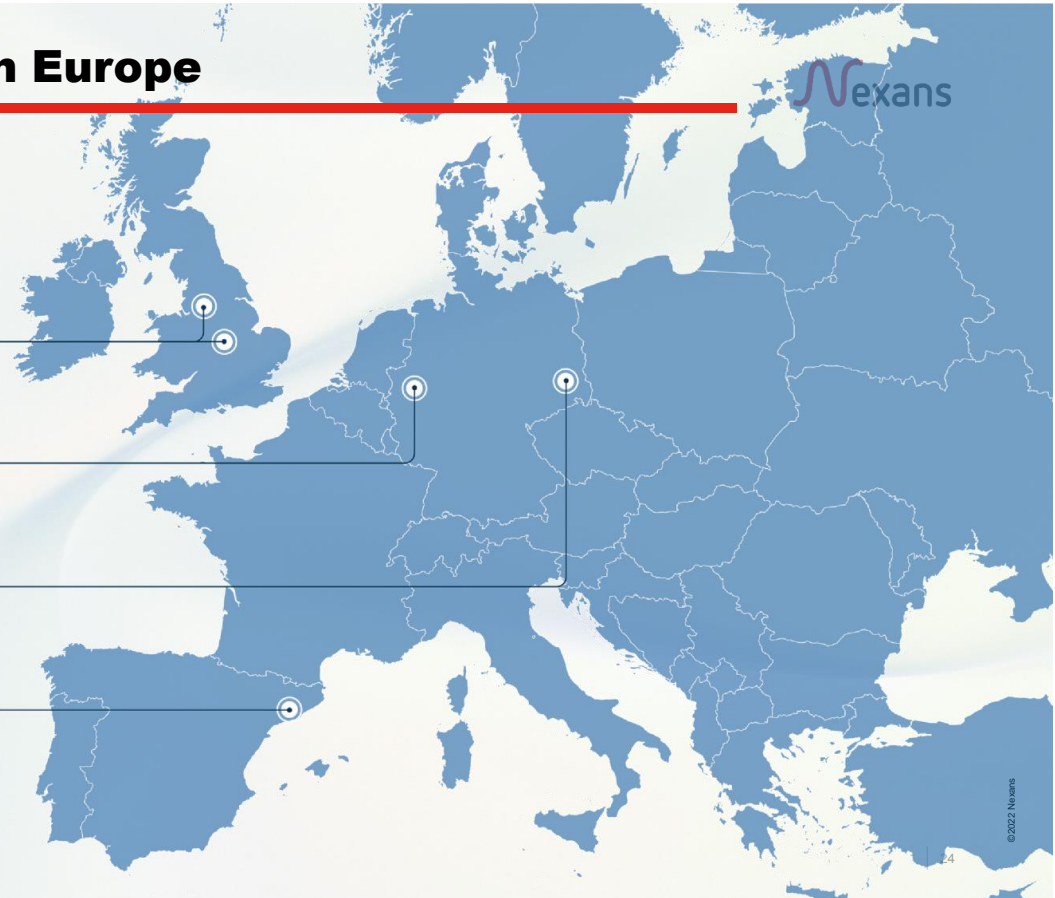



Take away from past FCL projects



What we learnt

- Liquid nitrogen cannot always be treated as network losses and re-invoiced to customers. Making it incompatible with grid operator business model.
- The continuous supply of liquid nitrogen by trucks creates some logistics and environmental impacts that make the model unsustainable in urban areas.



Trends for next projects

- In the future cryo-refrigerators are the preferred solutions.
- Need to improve cooling system efficiency and maintenance., especially for the range 1 to 5 kW @77K
- Production of liquid nitrogen from the air with a good level of purity (better than 99.5%)

3

NEXT STEPS

3.1 / COMED next phases

Targets of REG Networks using HTS cables



- REG Networks provide **resiliency** by creating grid **redundancy**
- REG Networks **connect** urban substations on the **distribution side**, effectively **reinforcing** the transmission system
- REG Networks provide **high capacity, distribution voltage connections** with minimal footprint, civil work and permitting
- Approach is independent of **transmission voltage levels**, but compliments the existing transmission system

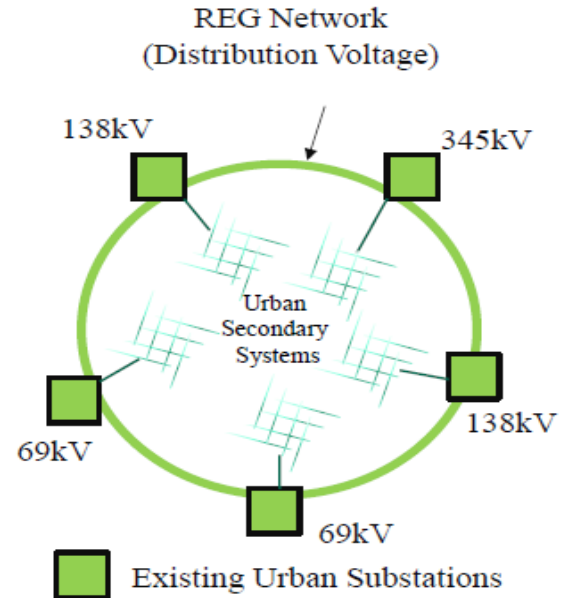

3.1 / Resilient Electric Grid (REG) Case using HTS cables in Chicago Central Business District



Intended to Provide Greater Resilience with Lower Cost and Less Disruption
Expected to increase reliability in the heart of the Chicago central business district

- **Two stations** are radial substations, served from 69kV sources. **One station** is looped at 138kV.
- Project intended to loop together all three substations into a network, increasing reliability and resiliency for all to N-3.
- **Expected to be far less disruptive** to the downtown core area than conventional transmission upgrades:
 - No **additional high voltage transformation**
 - No **significant infrastructure construction**
 - No **land acquisition for substation expansion**

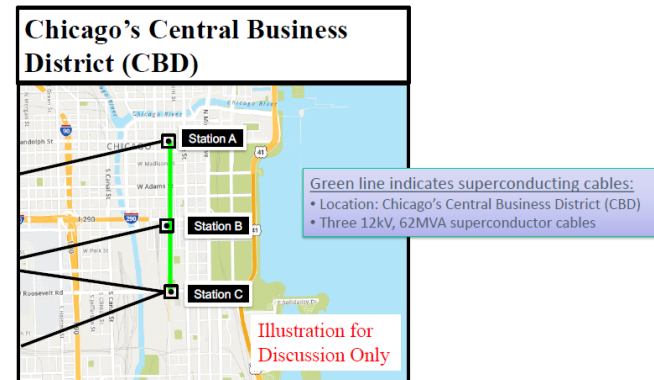

3.1 / How can HTS cables increase the network resiliency?



There are many variations of what resiliency means, but fundamentally they all encompass the following three areas:

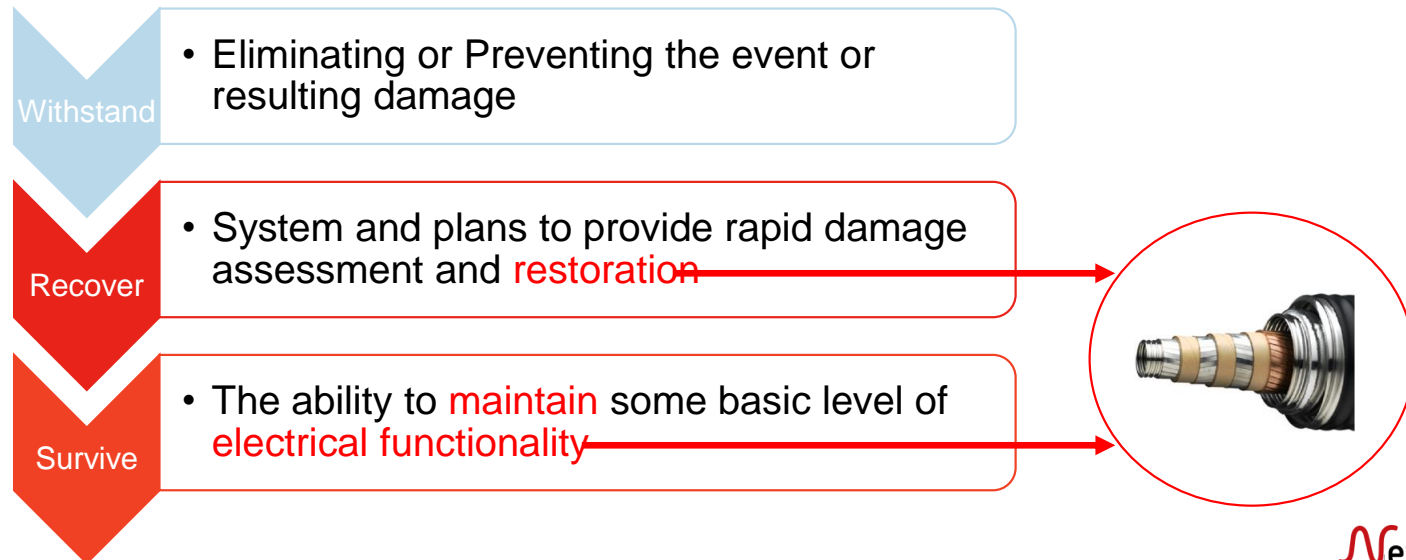

3.2 HTS solutions for Railways infrastructures







- SNCF constitutes a key customer for HTS cables and fault current limiters (FCL)
 - Technical team open to innovation
 - Partially-urban high-current MV network, both AC (25 kV) and DC (1500 V)
 - Facing strong challenges owing to increasing passenger traffic, over-used equipment, global warming leading to higher summer temperatures
 - Reference for addressing the world-wide railway infrastructure market
- Paris Montparnasse station
 - 200 000 passengers on working days and 750 trains per day on 28 tracks
 - Several electric breakdowns in the last years, including a blackout in July 2018 caused by a transformer on fire in the Issy-les-Moulineaux substation feeding Montparnasse



Launching of **SuperRail** Project to secure supply
of Montparnasse thanks to HTS cables

3.2 Focus on SuperRail Project



Set-up	<p>Consortium agreement with SNCF Réseau</p>  <p>Industrial partners</p>   <p>and academics</p>  
Main deliverable	Two 80-meter 1500 V DC, 3500 A HTS cables
Contracting scheme	Semi-turnkey : conception, cable system supply, installation, pulling and commissioning

3.2 / SuperRail objectives



ENABLE TRAFFIC INCREASE IN PARIS MONTPARNASSE

- Bring power to Montparnasse tracks using pipes embedded in an old bridge
 - Copper cables cannot transport the required power through the existing pipes
 - Only HTS cables can meet this goal
- Develop the French academic expertise and industry on HTS technologies
 - Involvement of Centrale Supélec and Université de Lorraine
 - Cable core manufacturing in Bourg-en-Bresse (in addition to the usual development in Calais)
 - Cooling system developed by Absolut System
 - Prototype loop testing in SNCF laboratory in Vitry-sur-Seine
- Anticipate the master plan for reinforcing the SNCF network

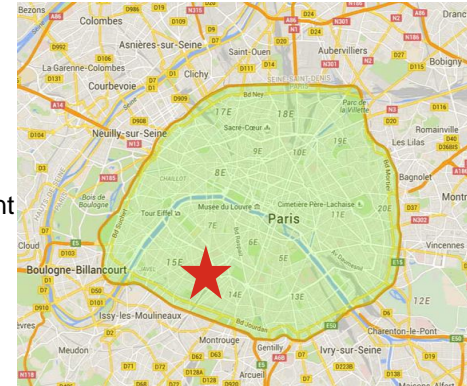

World's first HTS cable in a railway grid !

3.2 / SuperRail cable track

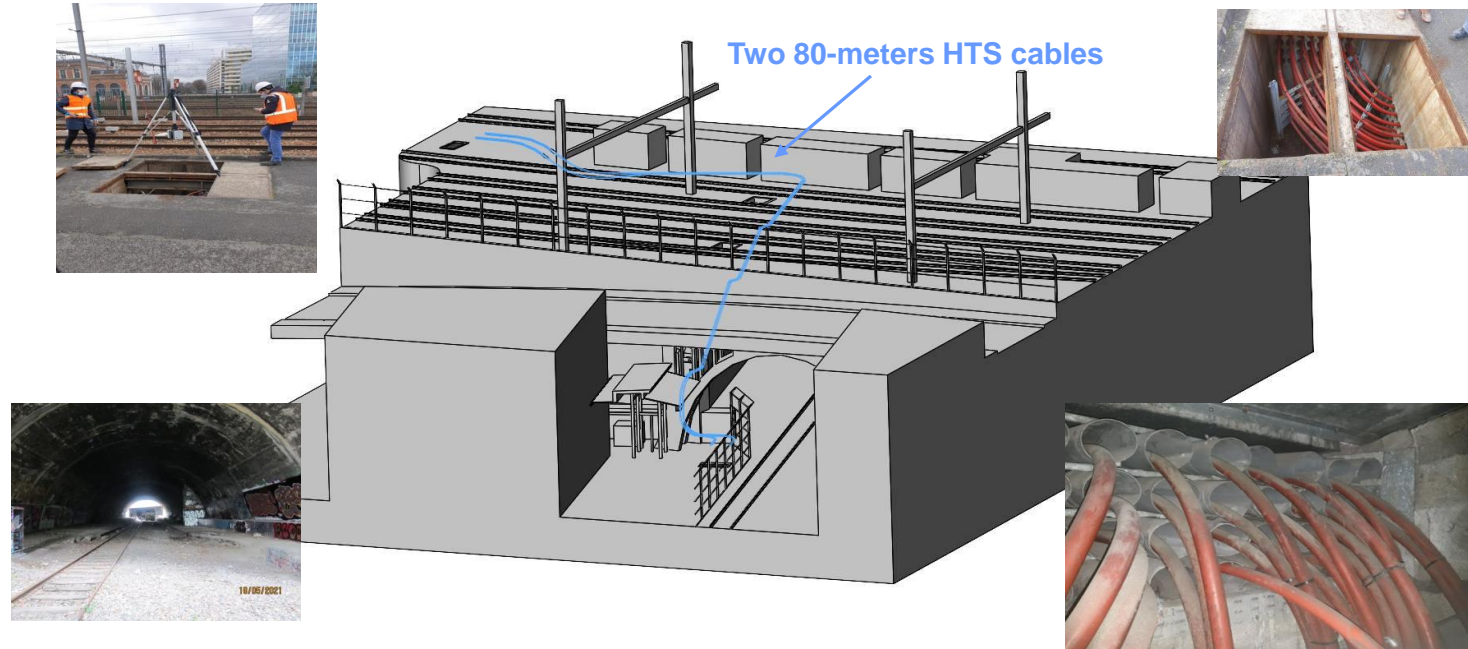

3.3 | MVDC HTS cables for offshore wind farm



3 MAIN DRIVERS HIGHLIGHTED BY TSO

- MVDC is naturally present in the energy conversion chain of offshore wind mill
- Superconducting cables can transport very large DC currents with no electrical loss
- Expected drastic reduction of footprint on the offshore platform (only switching station, no need for large transformer)

3.3 | MVDC HTS cable - Expected performances

KEY PERFORMANCES

- ✓ At 50 kV DC, offshore power links of 1 GW/per dipole are being considered , meaning a current of 10 kA DC requiring a section of 50 mm² of superconducting tapes
- ✓ Very limited right of ways at cable landing (trench of 1 meter) with no thermal or electromagnetic impacts
- ✓ Low overall losses = ~1 MW/GW transmitted over 10 km
 - Only cryostat thermal losses in the range of 2 to 3 W/m (4 cryostats in // for 2 monopoles of 500 MW)
 - A cryogenic cooling station (TBF 1050) is consuming 12 W of electricity in order to evacuate 1 W in cryogenic conditions

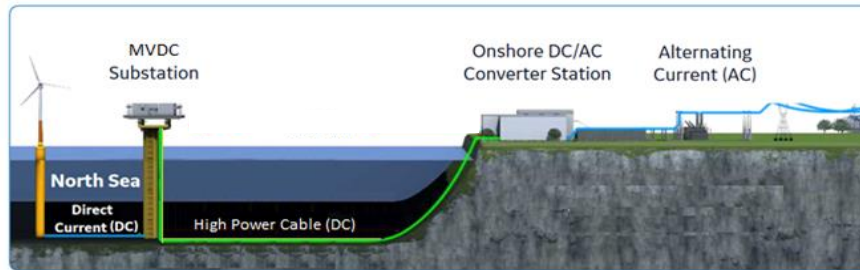

3.3 | MVDC HTS cable - What has to be developed ?



DEVELOPMENT STEPS REQUIRED

- ❑ For the superconducting cable system :
 - ❑ For cable length above 30 km = Intermediate Offshore platform for cryogenic cooling/pumping station,
 - ❑ Superconducting cable riser
 - ❑ Submarine joint

- ❑ For wind farm system components :
 - ❑ Output at 50 kV DC for wind mills
 - ❑ High current conversion (> 10 kA) station in the land power substation (PCCT)

3.3 | Key benefits of MVDC HTS cables



Offshore wind farms can benefit from superconducting cables through

- Lower losses, especially for system of 1 GW or more
- Reduced offshore foot print
- Smaller cable landing area

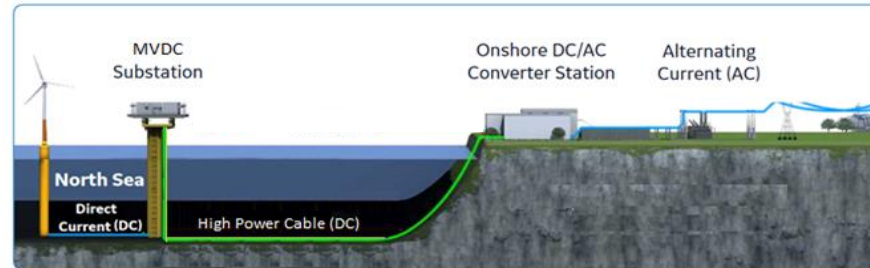

1.4 / Application of HTS FCL in Railways Networks

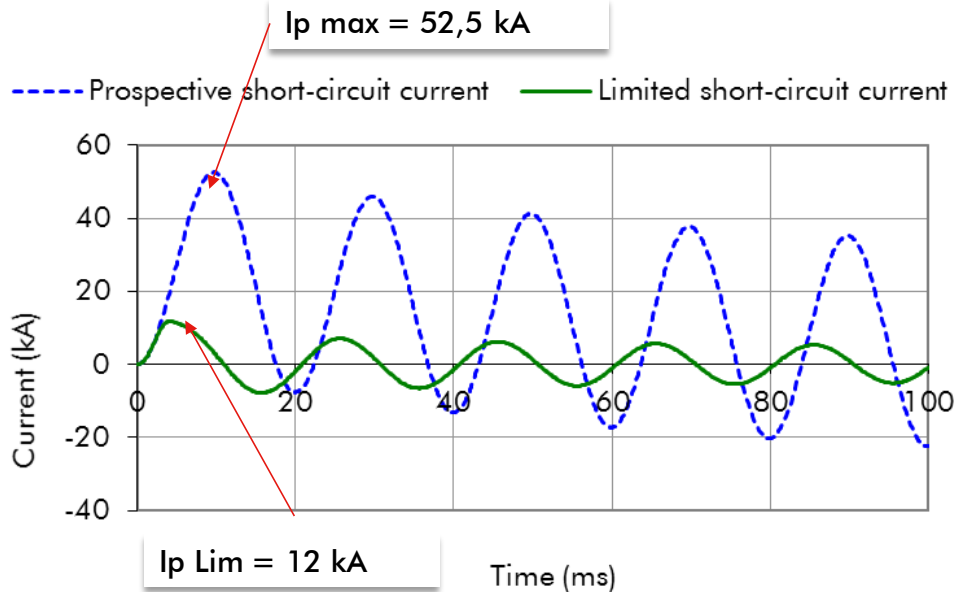

Rated Voltage	25 kV (monophasic)
Rated current	2000 A
Fault duration	100 ms



1.4 / Status of on-going FCL projects

Distribution grid

Europe = Numerous pilot and studies in the last 10 years but grids are not yet enough saturated to require FCL.

US = Simulations of future upgrade scenario of city center sub stations shows that FCL could save up to 100 MW of supply power in case of fault.

Railways networks

Short term pilot :

- Increase of high-speed train traffic
- Transformer and breaker protection

Long term prospective :

- 25 kV Transformer cost reduction
- Increase of supplied power by 1500 VDC stations

4

Need for a new modeling approach in industry

Status of modeling for grid HTS solutions



The aim of actual modeling activities for HTS cable and FCL is- to make sure that the superconducting systems are :

- designed to answer to customer specification
- safe during operation (fault events)

The questions raised by customers on the everyday life of HTS system show that we have to go further to use the full potential of superconductors :

- we need to model the full dynamic of the system all along the different life cycles (cooling down, warming up, recovery after fault...) , especially including the cooling system capacities and control

Need for dynamic models in HTS applications

Transient models of FCL :

- Adiabatic/Electrical FCL behaviour
 - Resistance as a function of dissipated energy
 - For a range of designs to be defined with customers (library)

.....to be associated with an active use of cooling system especially in recovery phases.

For HTS cable + cooling system :

Full Transient thermal model in order to optimize :

- Cooling down
- Warming up
- recovery after fault
- other events brought by customers

Goals of Twin models of HTS systems



Dynamic Models of HTS cable or FCL with their associated cooling system aiming at :

- developing and deploy automation programs for HTS systems
- giving planners models to anticipate the impacts of the integration of HTS solutions in the grid
- evaluating energy consumption and carbon footprint related to real load curves in HTS systems life cycles

Conclusion

Conclusions



- HTS cables and Resistive Fault current Limiters are mature technologies, industrially produced
- HTS solutions answer to the challenges of energy transition in city centers where space is limited, and civil works are very disruptive :
 - ***To secure and reinforce distribution grid***
 - ***To increase Train/Tram/Metro traffic, and e-mobility in general in the future***
- Modeling is a powerful way for HTS solutions to be considered by planners and engineers at the very early stage and make possible projects of grids expansion or reinforcement that are not possible or very disruptive with conventional technologies.