

# ***Rapid Iteration of HTS Magnet Technologies for Levitated Dipole Systems***

***Rod Badcock\****, Sriharsha Venuturumilli, Konstantinos Bouloukakis, Theo Wordsworth, Nancy Zhou, Tom Simpson, Emily Kei-Brewerton, James Rice, Kris Chappell, Mick McCrohon, Zvonko Lazic, Bradley Leuw, Emily Hunter, Raymond Hu, Kent Hamilton, Matthew Lynch, Thomas Berry, Darren Garnier, Craig Chisholm, Josh Ellingham, Patrick Coulson, Ratu Mataira

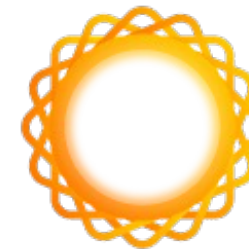
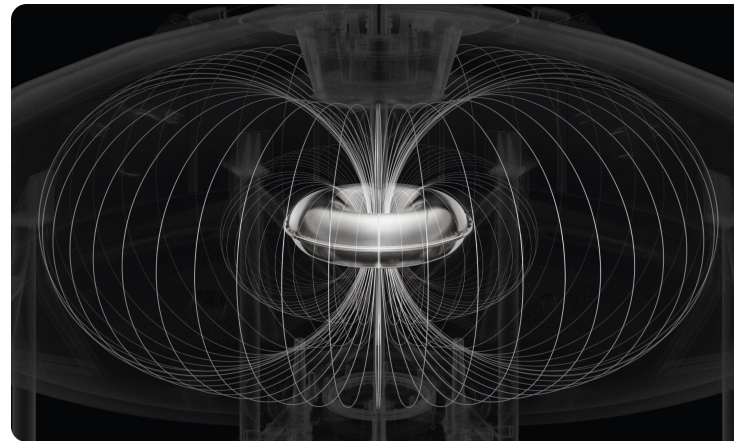

**OPENSTAR**  
TECHNOLOGIES LTD

***\*rod.badcock@openstar.nz***



# Levitated dipole fusion

*Inverting the typical plasma / magnet MCF arrangement*

*\*Proposed by the late Prof. Akira Hasegawa.*

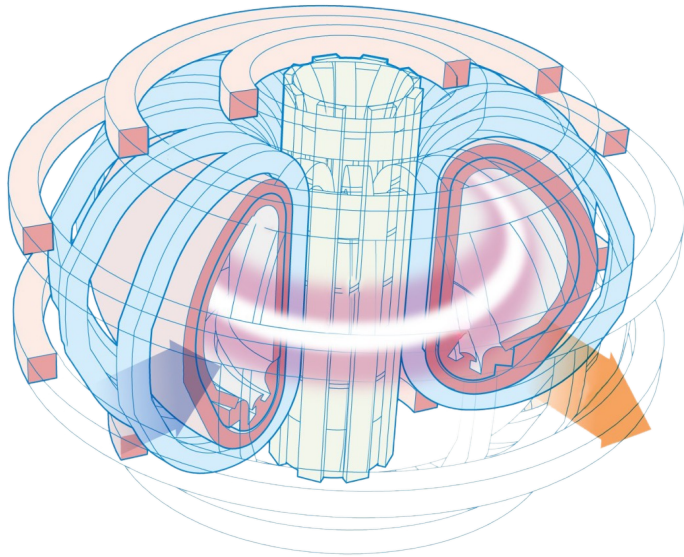

TRADITIONAL MAGNETIC CONFINEMENT

Primarily toroidal field + auxiliary Poloidal

Plasmas inside the magnet

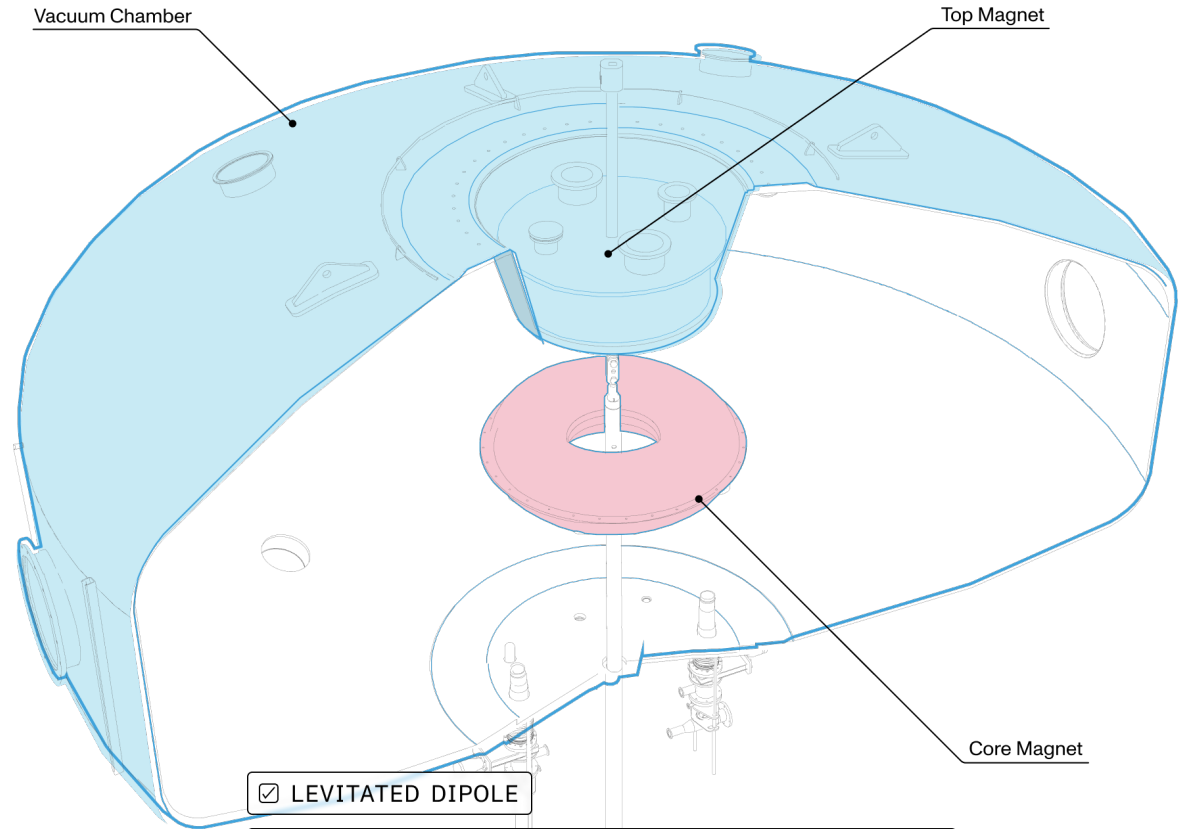

LEVITATED DIPOLE

Only poloidal field

Magnet is now inside the plasma

# OpenStar Technologies

## “Junior” Levitating Dipole

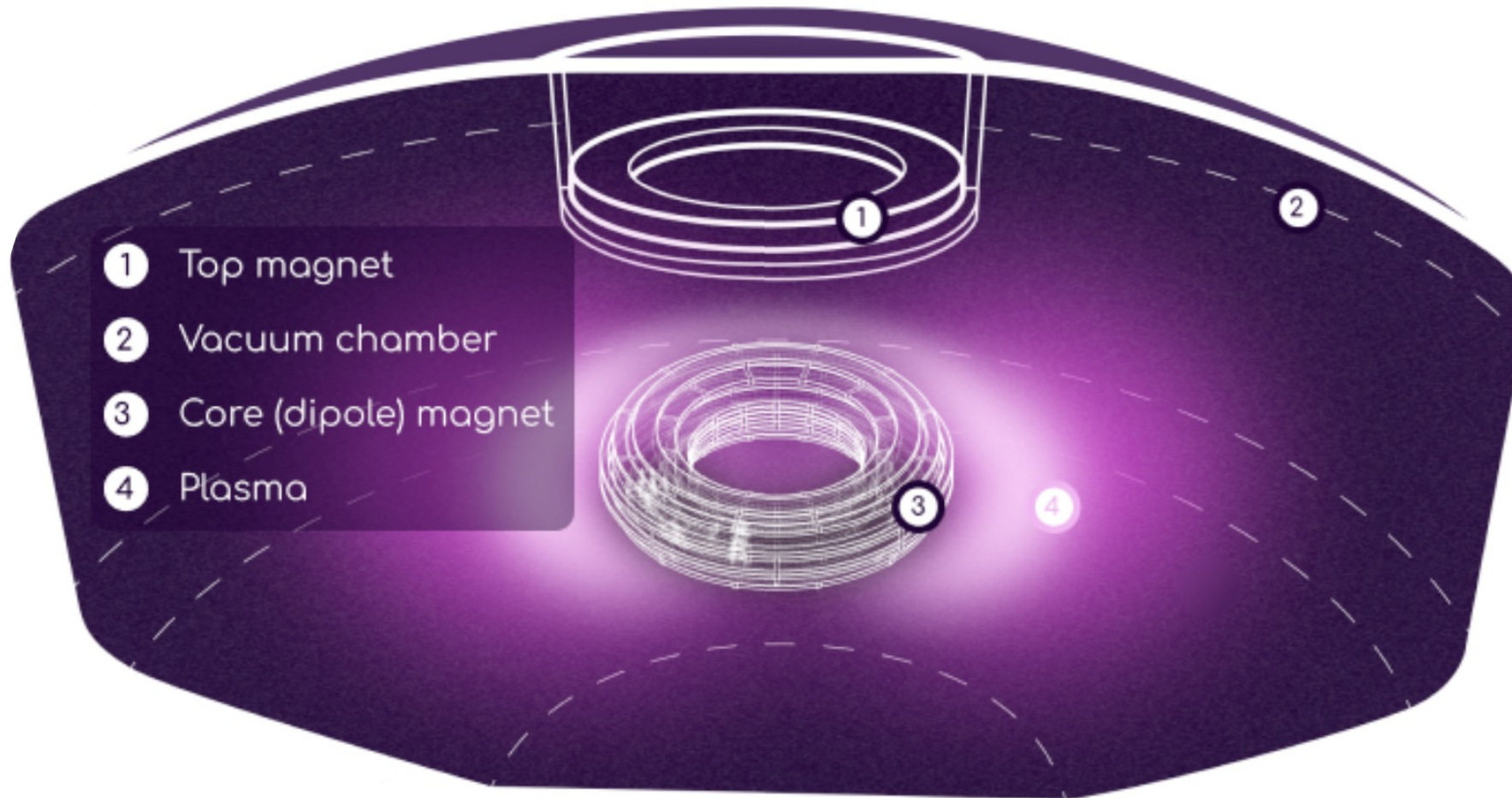

---

5.6 T using HTS magnets

---

1.4 kA onboard flux pumps

---

500 kg levitated from above

---

5 m wide plasma

---

< 50 kW heating system

---

# Modular design

## “Junior” Levitating Dipole

☑ RAPID RND

The dipole is uniquely modular, allowing for simple design and construction.

This allows for rapid system iteration and ease of upgrade pathway.

Maintenance is straightforward, all components can be removed and replaced with ease.

For power plants this will lead to excellent plant availability.

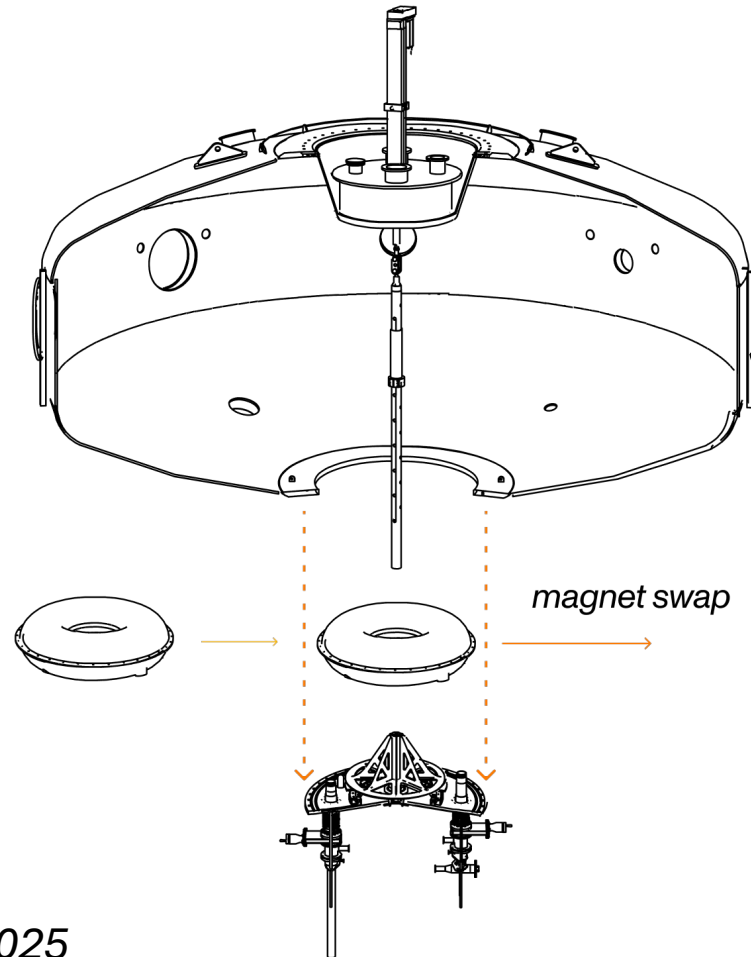

From Ratu Mataira – SOFE 2025

# Iteration

*Levitating dipole – allows a fast turn-around*

- An easily removable dipole magnet simplifies test cycles
  - Test-cycles every **two weeks**
  - Iteration around every **two months**

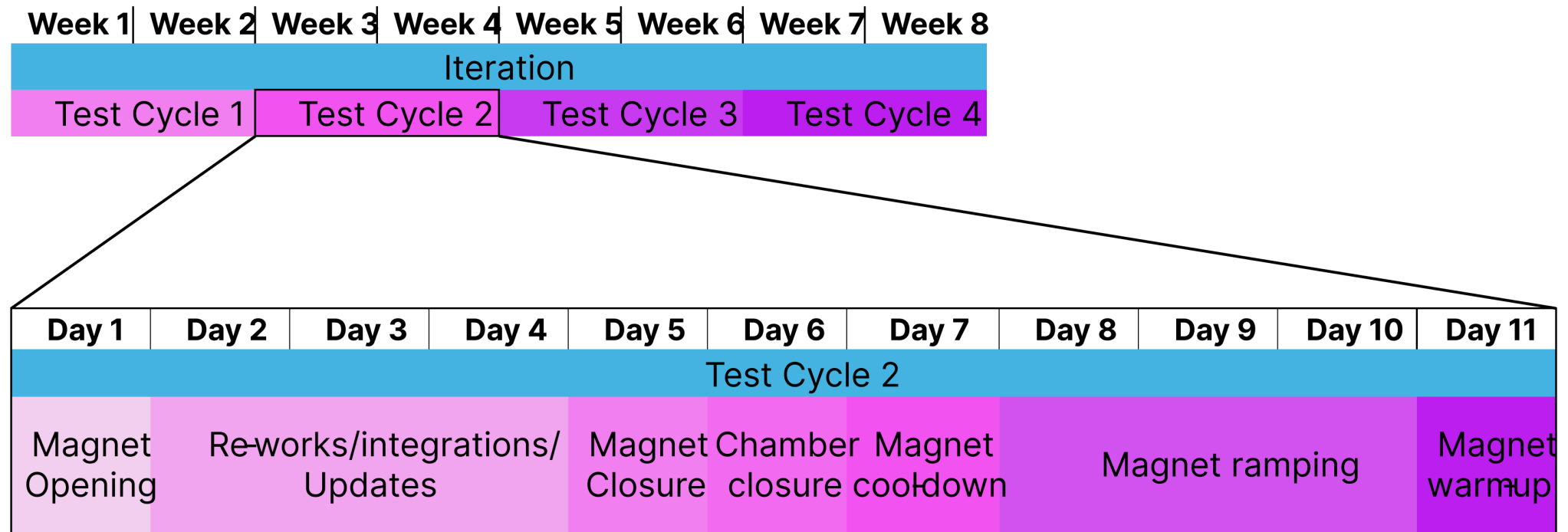

# Core Magnet

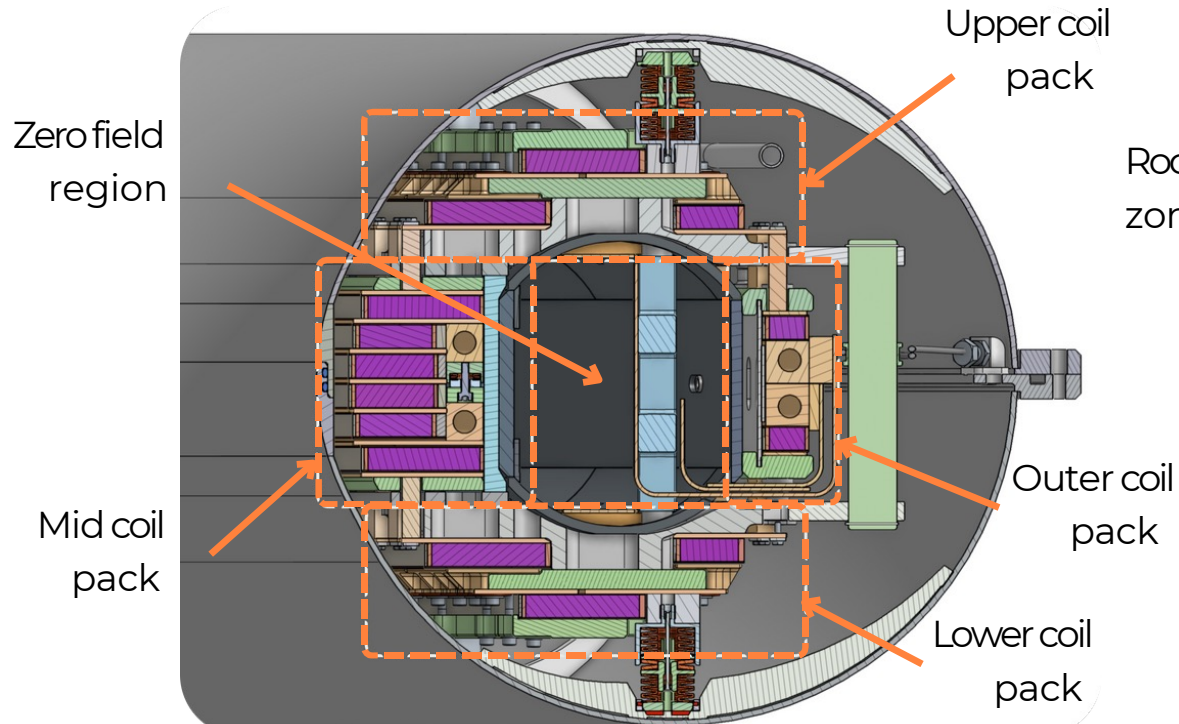

Core magnet CAD cross-section

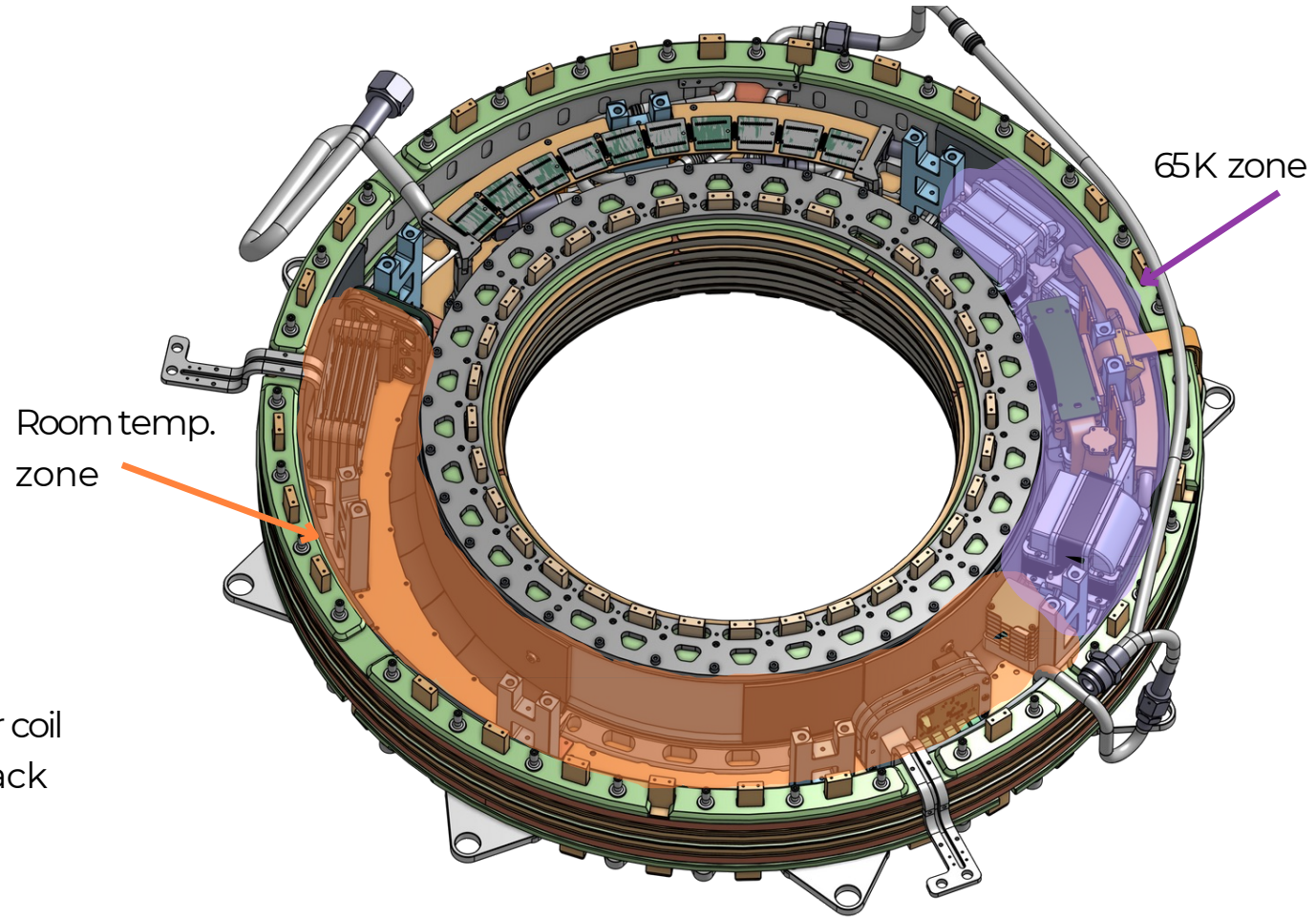

Temperature zones within the zero field region

# Cooling system

## Gas He<sub>2</sub> down to 25 K

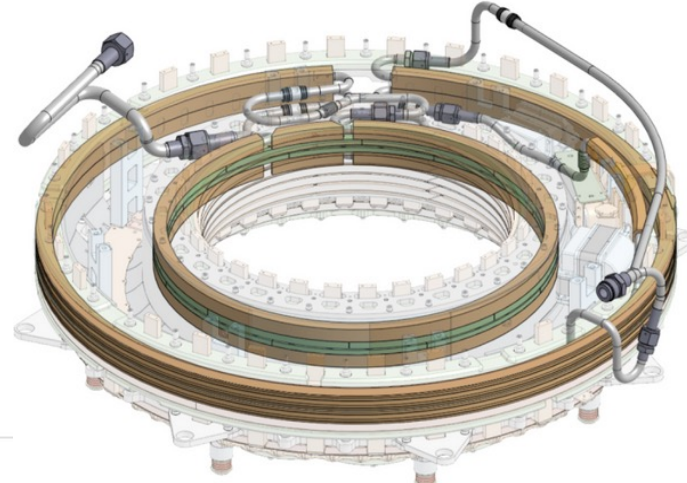

Magnet Heat Exchangers

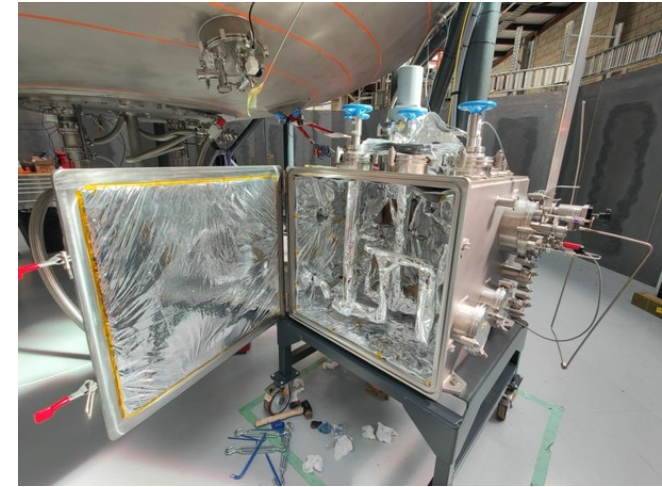

Cryo-box open

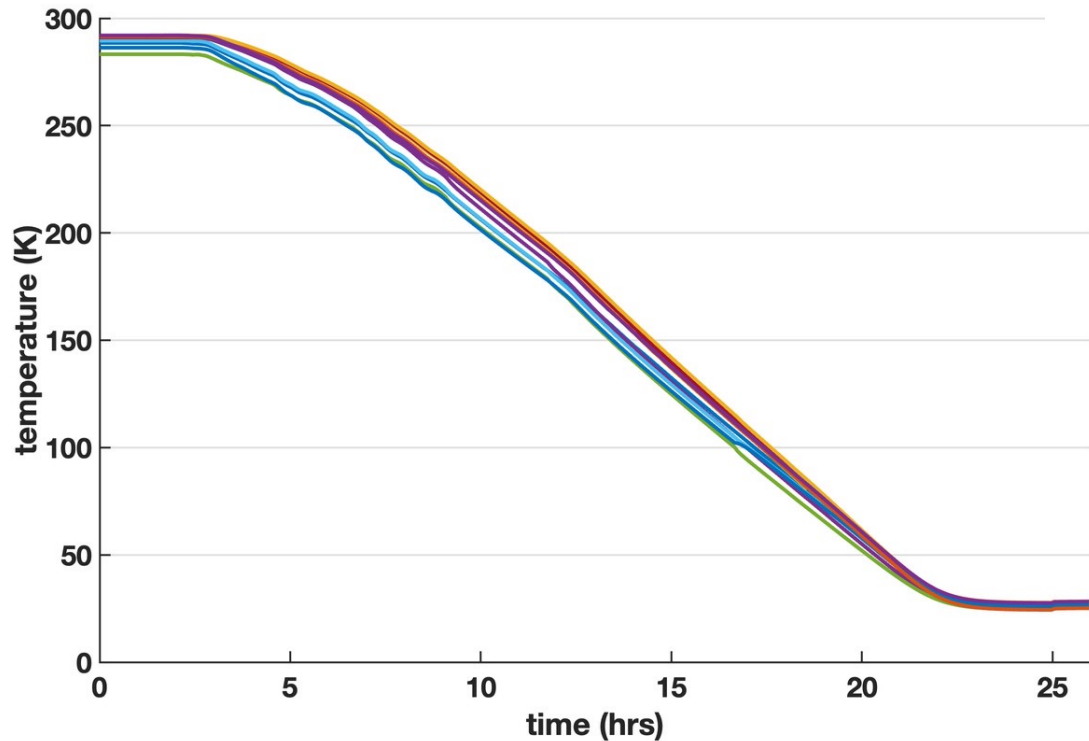

Coil temperatures during cooldown

- 2 cryo-coolers
- 310 W total power @ 30 K
- 15 bar gas He<sub>2</sub>
- Modulated cooling power
- 20 h magnet full cooling
- Designed and built in house

# Superconducting Power supplies

## Technology development

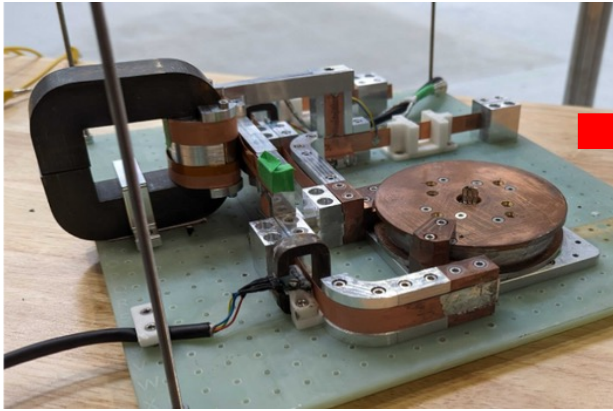

Prototype on breadboard

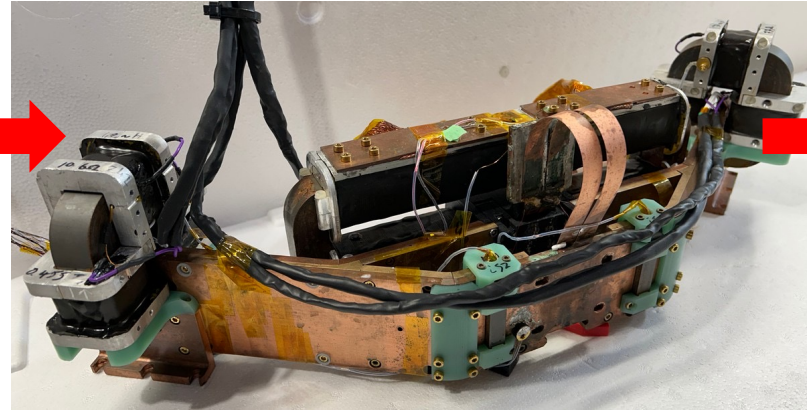

CT2.2

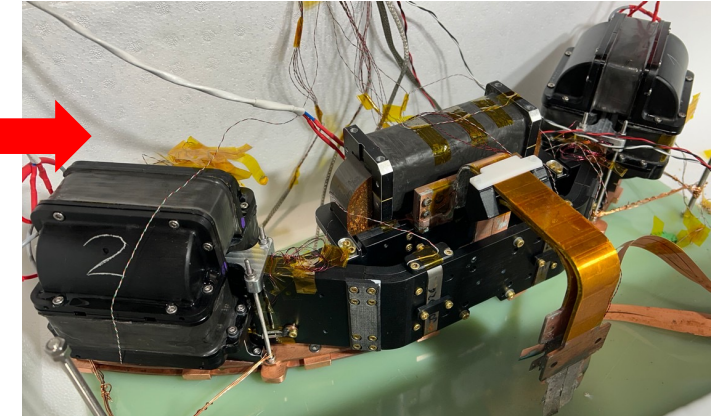

CT2.3

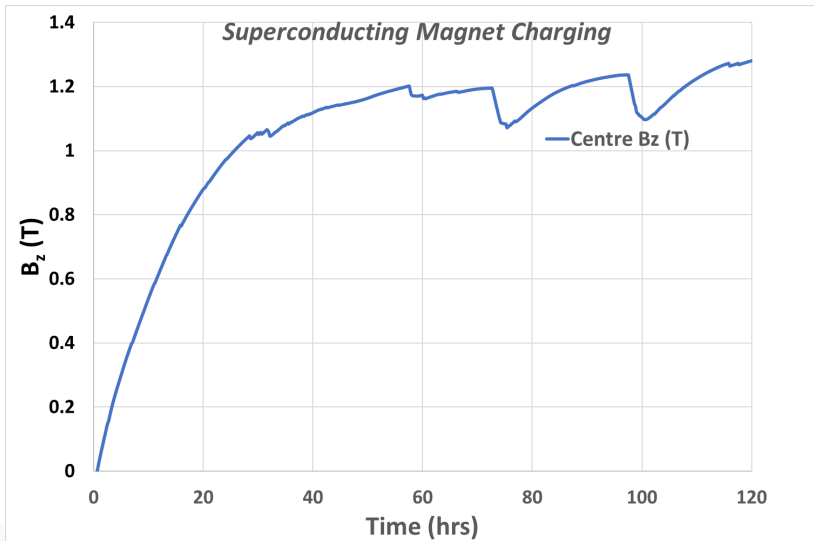

1440 A out



1350 A out



CT2.4



Flux Pump  
100 W in



Traditional Power  
Supply - 13.5 kW in



OpenStar Magnet Iteration  
Wed-Mo-Or1-01 3<sup>rd</sup> July 2025

# Electronics and batteries

## *Evolution of Diagnostics and Drivers*

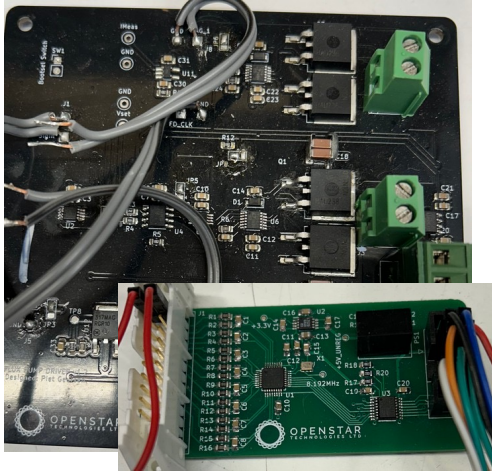

Prototype

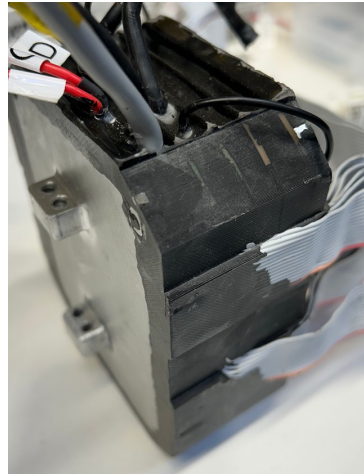

Donut Brain

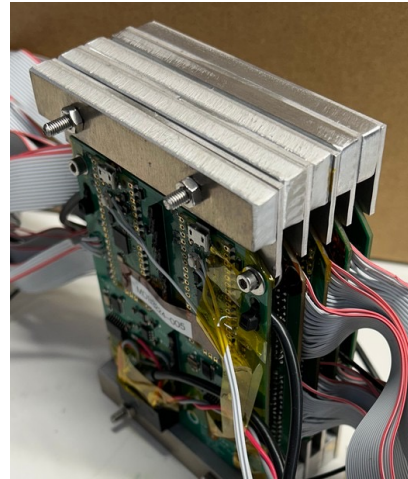

Donut Matter

Electronics made in-house to suit the system's needs

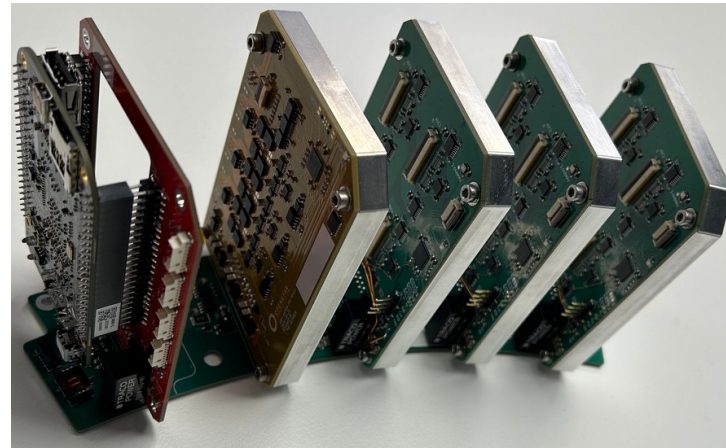

Grey Matter

### **720 Wh energy stored in batteries**

- Energize the magnet
- Run diagnostics
  - ~50 temperature sensors
  - ~10 hall sensors
  - ~2 vacuum sensors
  - ~40 voltage readings
  - ~5 current sensors



# Iteration

## Delivering first plasma

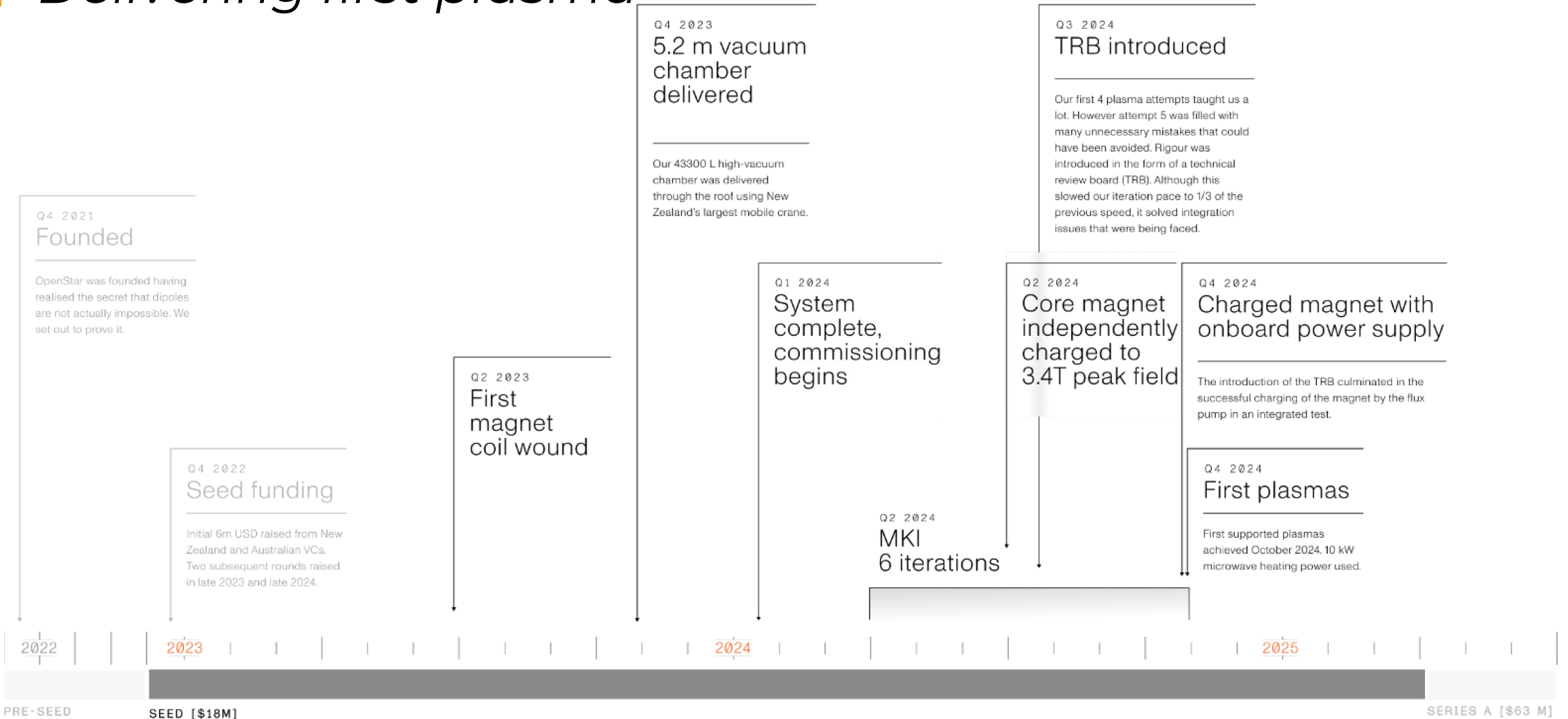

# Junior iteration path

*Better power, cryogenics, heating, diagnostics and magnets*

Core magnet:

- MKII
  - Improving float times
  - Standardised interfaces with subsystems
  - Improved zero field region
- MKIII
  - Quench management
  - Stress monitoring
  - Magnetic field homogeneity
  - Increasing magnet field (16 T)

Top magnet MKII:

- Quench resistance
- Mechanical stability
- Magnetic alignment

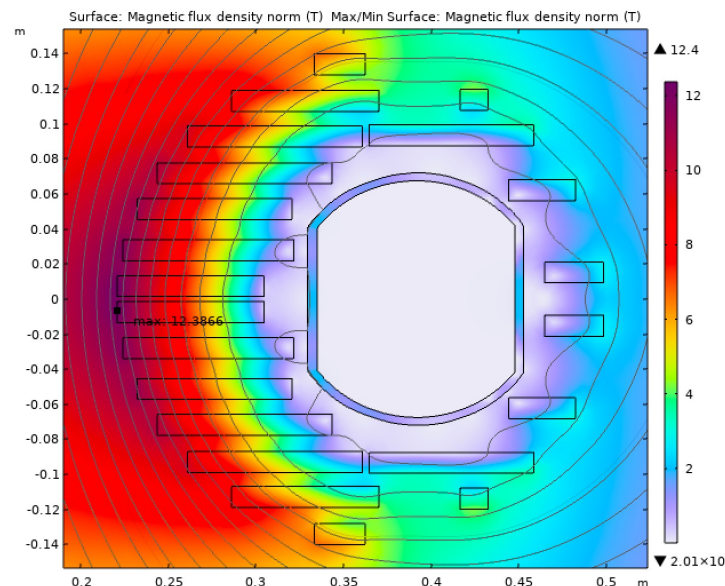

# Core Magnet: MKIII

- More advanced version of MKII; Advancing plasma science by doubling B-field up to 16 T.
  - Hybrid cooling demonstration with advanced quench management
  - Iterated optimisation of zero-field equipment space
- Critical spec.
  - Magnetic field on tape: 16 T
  - Operating temperature 25K and 20 to 50 K
  - Hybrid cooling
  - Axisymmetric B-field 100 ppm
  - 2 hr float time
  - Operating current 1.44 kA
  - Reduced coil pack resistance  $< 6 \mu\Omega$

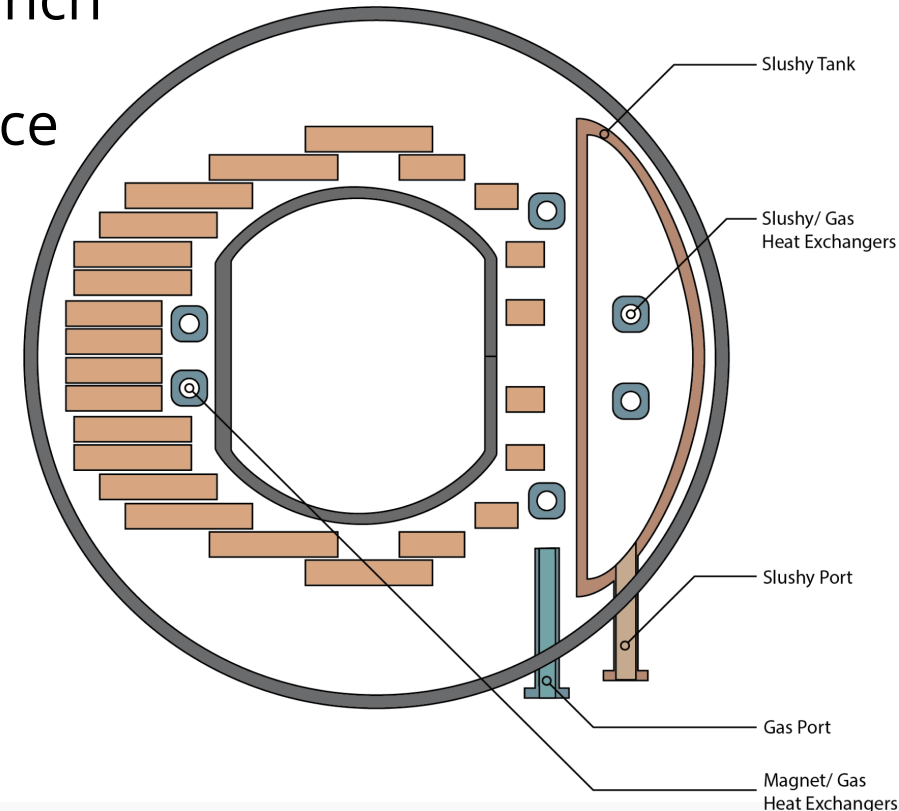

# Top Magnet: Iteration

Active magnetic levitation

Cryocooler at 180°

Cryocooler at 000°

HTS Current Terminals

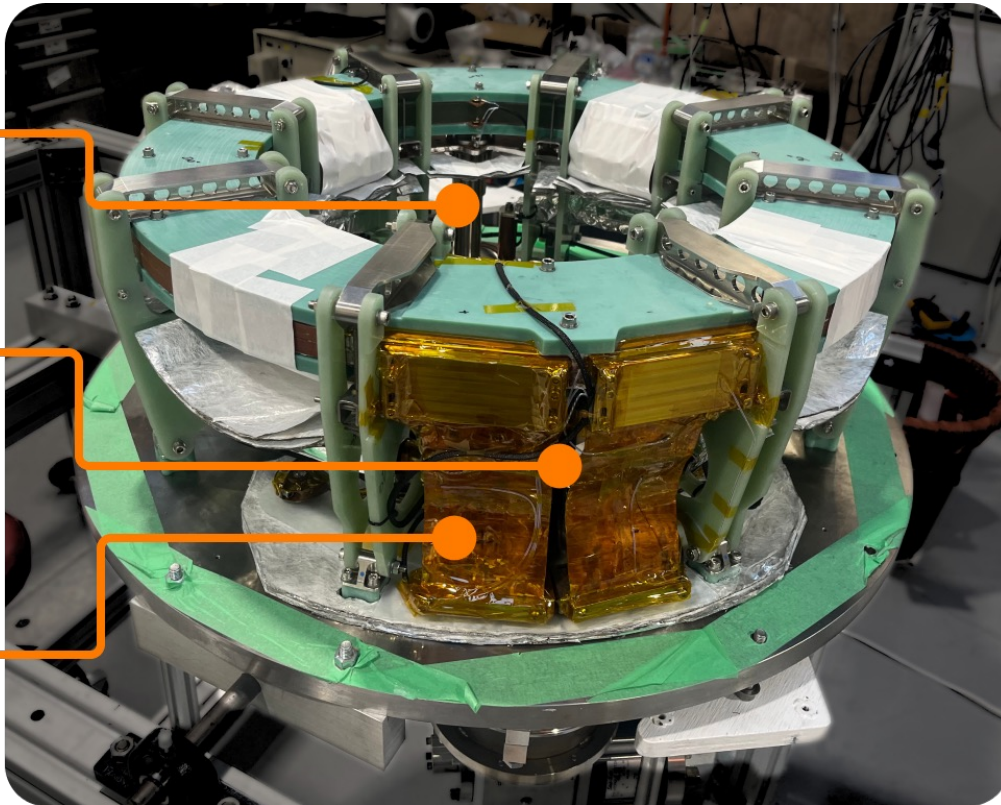

- Currently an insulated magnet technology
- Key to maintaining levitation under AC control

Key Specs:

- Operating temperature 30 to 50 K
- Operating current 700 A
- Reducing coil pack resistance  $< 1 \mu\Omega$

# Fast iteration

*Modular technology, modular design, modular dipole*

The key to rapid fusion development:

- Five full integration cycles ✓
- Four superconducting supply generations ✓
- Four generations of electronics ✓
- Two generations of top magnet ✓
- The modular dipole allows fast iteration cycles



# Questions?

- Other relevant presentations
- **Sat-Mo-Or2-03:** Achieving full-field magnet performance: insights from Openstar junior experimental campaigns 1 and 2.
- **Wed-Af-Po.08-04:** [Invited] Test facility for rapid and iterative evaluation of magnet technologies at OpenStar Technologies Ltd.
- **Wed-Af-Po.12-03:** HTS Power Supplies for DC Fusion Magnets
- **Sat-Mo-Po.05-01:** From Modelling to Application: Exploring Quench Tolerance in High-Field HTS Magnets.
- **Thu-Mo-Po.07-05:** System modelling and optimisation of the Openstar HTS dipole magnet with transformer rectifier flux pump using MATLAB/Simscape
- **Sat-Af-Mem1-01:** [Invited] High Field HTS magnets and the legacy of Huub Weijers: from the earliest days of the NHMFL to today