

# Review of Cryogenics for Large Superconducting Systems

Laurent Tavian

CERN, Accelerator Technology Department, CERN-AT, Geneva 23, CH 1211, Switzerland  
phone: +41 22 767 6959; e-mail: [laurent.tavian@cern.ch](mailto:laurent.tavian@cern.ch)

**Abstract** – Cryogenics constitutes key enabling technology of large superconducting systems and plays a major role in the large scientific instrumentation projects. Large cryogenic systems incorporate high-efficiency helium refrigeration (liquefaction) at 4.5 K or below 2 K, a distribution system with low heat-in leaks and a large helium inventory (storage). The technology developed for the Large Hadron Collider (LHC) under commissioning at CERN has become a reference for the cooling of future large superconducting system, making industrially available new standards for materials, devices, insulation techniques, device cooling methods and cryogenic refrigeration.

**Index Terms** – Cryogenics, Superconducting system, Helium refrigeration

Manuscript received October 1, 2007; accepted October 27, 2007; Reference No. CR4; Category 6 and 11.

## I. INTRODUCTION

Large scientific instruments based on superconducting technology require low temperature operating conditions and, consequently, the parallel development of the supporting cryogenic technology. Therefore, large cryogenic systems have to be designed with high demands in terms of development effort, performance and operational availability. After describing the role of cryogenics and the main features of the cryogenics systems, we present the Large Hadron Collider (LHC) cryogenic system, which is presently the largest system ever built, and review several projects in construction or under study with emphasis on their specific requirements, constraints and solutions. This review complements the [review C2](#) “Accelerators and Superconductivity: LHC and Near Future in Europe”, authored by Lucio Rossi, and published in the 1<sup>st</sup> Issue of this Forum.

## II. ROLE OF CRYOGENICS

To reduce the capital and operation costs of large-scale projects requiring magnetic or electrical fields, compactness is attained through higher fields generated by superconducting devices. Accordingly, cryogenics needed to cool large superconducting systems plays a major role in these projects. Such is the case of cooling the superconducting bending and focusing magnets in circular accelerators and the superconducting rf acceleration cavities in linear accelerators [1]. It is also the case of cooling large superconducting magnets which confine and stabilize plasma in thermonuclear fusion tokomaks.

Cryogenics plays also a role in improving of the environmental conditions. Cryogenic pumping improves the vacuum required in the beam chamber of particle accelerators. In addition, by reducing the electrical resistivity of the beam chamber, low temperature allows

one to increase the beam stability and life time. Cryogenic pumping plays also a major role in trapping of radioactive particles in thermonuclear fusion tokomaks.

Cryogenic environment offers also a better transparency of particle spectrometers in which particles have to be bent by a magnetic field but must not be perturbed by bulky bending devices.

In particle detectors, the background noise due to the thermal activity can be reduced by lowering the temperature of the sensing device; the level of detection can thus be improved considerably. A detector through calorimetry or tracking requires also large amounts of cryogen.

The reasons for using cryogenics in particle accelerators are summarized in the diagram shown in Fig. 1.

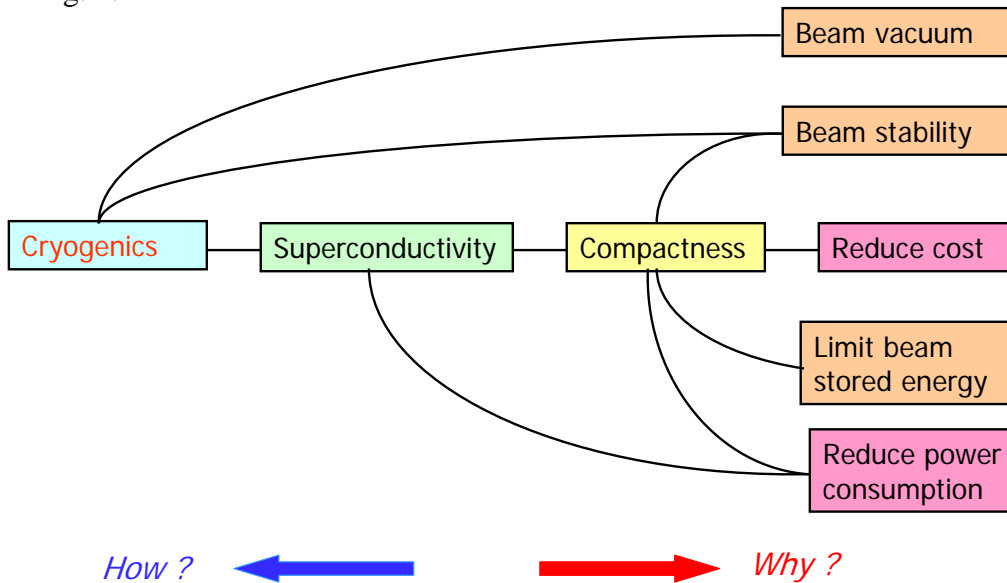

Fig. 1. Rationale for cryogenics in particle accelerators

### III. THE CRYOGENIC SYSTEM

#### A. The Helium Refrigeration System - 4.5 K Refrigeration

The energy penalty imposed by the operating at low temperature can be much worsened by the presence of internal irreversibilities impacting on the overall efficiency of the refrigerator, and hence on its capacity and energy consumption. For cryogenic plants producing several kW of cooling power, the main factor driving the optimization of refrigeration cycles and the choice of machinery such as compressors, heat exchangers, expanders and valves, is therefore the second-law efficiency, achieved by limiting irreversibilities in heat transfer and fluid flow. In this fashion, the large cryogenic helium refrigerators which all operate today on variants of the Claude cycle [2], have seen their efficiency improving significantly over the past decades to reach some 30 % of the reversible Carnot cycle. Consequently, an excellent performance of large thermodynamic machines operating between 4.5 K and 300 K has been attained [3]. Moreover, in the case of strongly varying load, this performance can be preserved over a wide dynamic range thanks to elaborate control techniques implemented with programmable logic controllers and computers. These refrigerator plants operate continuously for more than 6000 hours per year, showing availability in excess of 99 % and requiring only one scheduled annual maintenance period. It is the advent of such efficient and

reliable industrial helium refrigerators (see Fig. 2) which opened the way to the large-scale applications of superconductivity.

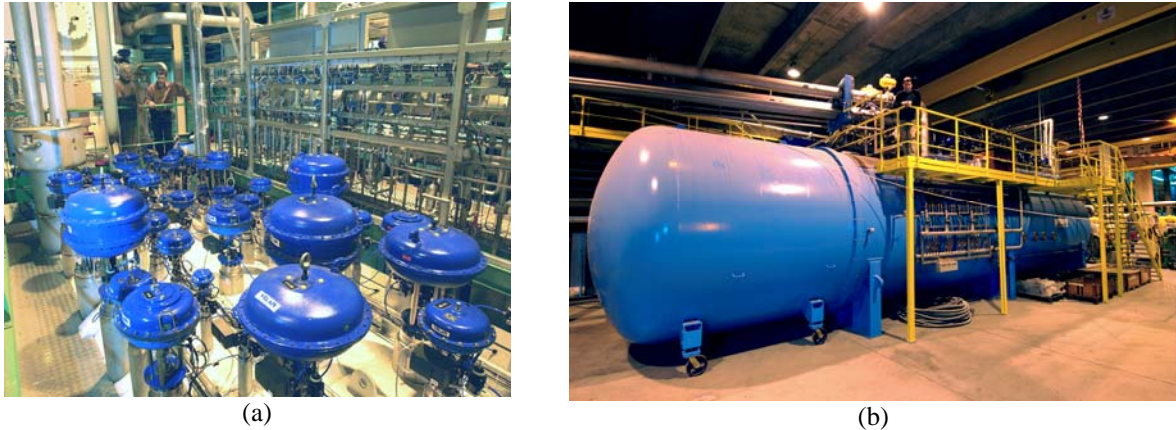

Fig. 2. Air Liquide (a) and Linde (b) large 4.5 K refrigerators for LHC cooling

### *B. The Helium Refrigeration System - 2 K Refrigeration*

Once a curiosity of nature and still today an arduous research topic in condensed-matter physics, superfluid helium is also a technical coolant for advanced superconducting devices. It is now implemented in industrial-size cryogenic systems, routinely operated with high reliability. Two main reasons justify the use of superfluid helium as a coolant for superconducting devices, namely the lower temperature of operation, and the enhanced heat transfer properties at the solid-liquid interface and in the bulk liquid.

Large cryogenic capacity below 2 K [4] requires compressing the pumping flow from a few kPa up to the atmospheric pressure by using a multistage compressor set. In contrast to conventional 4.5 K cryogenic systems, large superfluid cryogenic systems require in addition cold compressors, possibly warm sub-atmospheric compressors and low-pressure sub-cooling heat exchangers. Performing the whole compression at room temperature is not compatible with the pumping speed of warm machines. Consequently, the very-low-pressure gaseous helium has to be pumped at low temperature when it is dense, and cold compressors are required at least for the first stages (see Fig. 3a and 3b). The high compression stage may be performed by warm sub-atmospheric compressors. To increase the efficiency of the final Joule-Thomson expansion producing the saturated superfluid helium, the incoming liquid helium is sub-cooled down to 2.2 K in counter-flow heat exchangers. The efficiency of the 2 K refrigeration units, which can reach some 20 % of the reversible Carnot cycle, depends on the isentropic efficiency of cold compressors which has also significantly improved during the past decades to reach 75 %. Fig. 3 shows the cold compressor cartridges developed for the cooling of LHC.

### *C. The Cryogenic Distribution System*

In view of the high thermodynamic cost of refrigeration at low temperature, the thermal design of the cryostats, distribution boxes and transfer lines aims at intercepting the largest fraction of applied heat loads at higher temperature by means of thermal shield and intermediate heat intercepts, which must to be reliably implemented on an industrial scale. These include low-heat-conduction support posts or spacers made of non-metallic glassfibre/epoxy composite, low-impedance thermal contacts under vacuum for heat intercepts and multi-layer reflective insulation wrapping of cold surface areas. Fig. 4 shows the compound cryogenic transfer line installed in the LHC tunnel.



**Fig. 3.** Helium cold compressors for LHC cooling: IHI (a) and Air Liquide (b) compressors

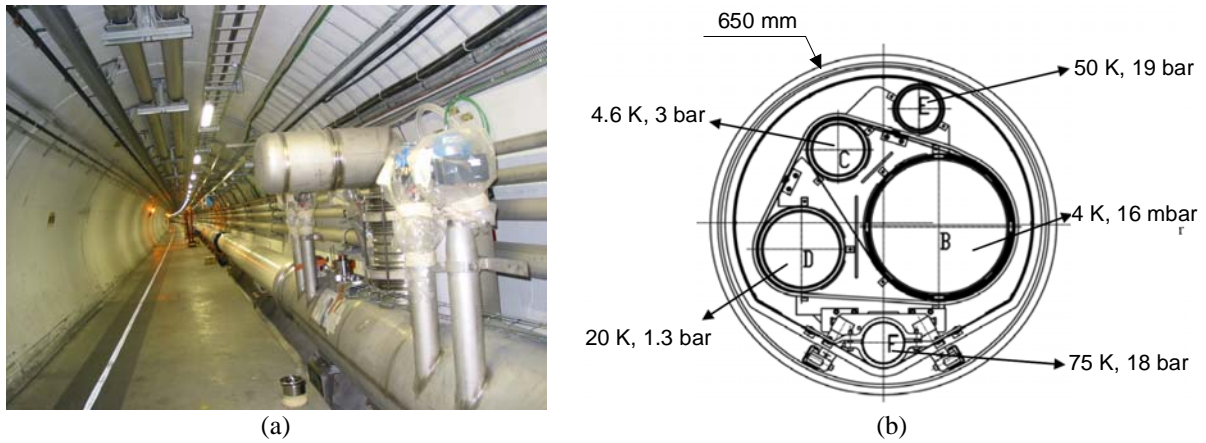

**Fig. 4.** Photo of the LHC transfer line installed in the tunnel (a) and sketch of the standard cross-section (b)

#### *D. Helium storage and inventory management*

For closed-circuit cryogenic systems which encounter relatively long shutdown periods without possibility of re-liquefaction, and fast helium discharges (magnet quenches), medium-pressure (MP) gas storage at 2 MPa and 300 K is commonly used (see Fig. 5a). Liquid reservoirs up to unit capacity of 120,000 liters (see Fig. 5b) offer a more compact storage, but a small cryoplant is required to permanently re-liquefy the boil-off.

Due to the huge helium inventory of some systems, the MP storage capacity could be deliberately limited, in order to minimize investment. Consequently, at the LHC it is foreseen to shuffle helium from the cryogenic system to the market during the periodic shutdown in the framework of a “virtual storage” type contract.

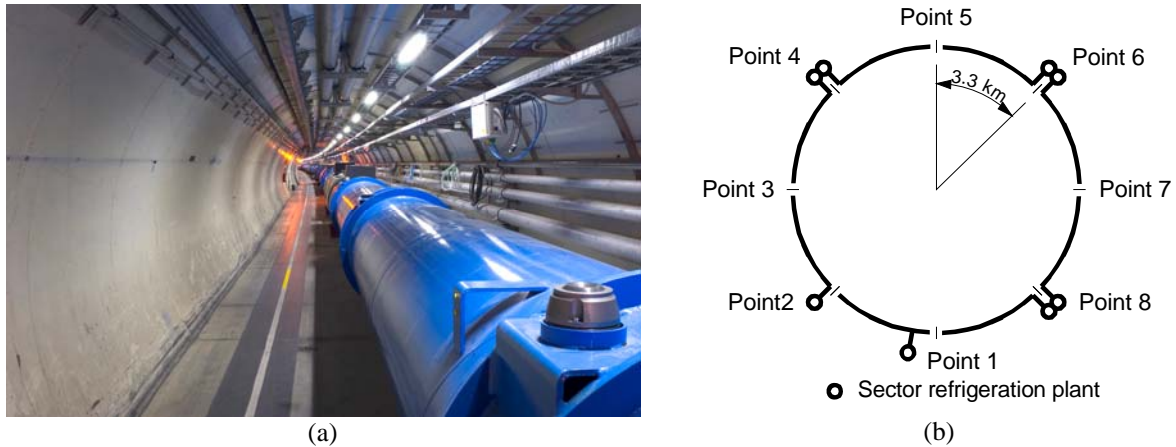

**Fig. 5.** Helium storage at LHC:  
250 m<sup>3</sup> medium-pressure helium storage tanks (a) and 120,000 l liquid-helium reservoir (b).

#### IV. THE LHC CRYOGENIC SYSTEM

The Large Hadron Collider (LHC) under commissioning at CERN [5] is a high-energy, high luminosity proton and ion collider, with beam energy of up to 7 TeV. It re-uses the 26.7 km circumference tunnel and infrastructure from the previous LEP machine. The beams will be guided and focused by high-field superconducting magnets [6]: 1232 twin-aperture dipoles of 8.3 T, 474 quadrupoles and 7612 corrector magnets of diverse types. The main magnets use 7000 km of Nb-Ti Rutherford-type superconducting cable, operating at 1.9 K in static pressurized superfluid helium [7]. All magnets, produced by industry, are assembled into their cryostats and individually cold tested at CERN before installation and interconnection in the tunnel (See Fig. 6a). The machine is composed of eight 3.3 km long sectors, individually cooled and powered. Cryogenic refrigeration is lumped in five “islands” with cryoplants serving the adjacent sectors (see Fig. 6b). Each cryoplant is constituted of a helium refrigerator of 18 kW at 4.5 K equivalent capacity, feeding a 2.4 kW at 1.8 K refrigeration unit. Sub-atmospheric compression of helium vapour from 1.5 kPa to 0.13 MPa is performed by multi-stage cold hydrodynamic compressors and warm volumetric compressors [8]. Cryogenic distribution in the tunnel is achieved through a compound helium line connected to the elementary magnet strings at every 107-m-long cell [9]. The cold mass of the LHC amounts to 37,000 tons: it will be cooled from room temperature in 15 days by vaporizing 10,000 tons of liquid nitrogen. The helium inventory in the system is 115 tons. Powering of the 1720 independent electrical circuits, with currents from 60 A to 12 kA, will be done through 3284 current leads, of which the 1182 with higher current rating are made of a high-temperature superconductor [10].

Four main physics experiments are under construction around the LHC. In the case of magnets for particle spectrometers, the final choice (superconducting vs. resistive) was dictated by economy and/or “transparency” of the mechanical structure along the path of particles crossing the detector volume. These basic design criteria have led CMS and ATLAS [11,12], the two largest LHC experiments, to construct superconducting spectrometers of unprecedented size operating at 4.5 K. ATLAS and CMS experiments have independent refrigeration plants separated from the cryogenics of the LHC accelerator itself.

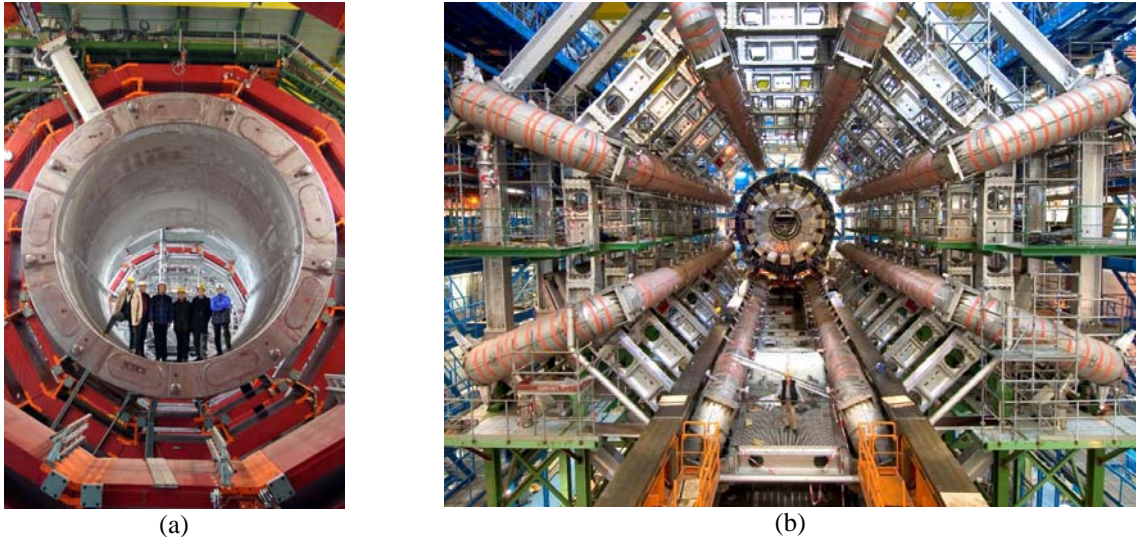

**Fig. 6.** The Large Hadron Collider: the view of the tunnel with installed dipole magnets (a) and the general cryogenic system layout (b)

CMS is based on a single large solenoid (length 13 m, inner diameter 5.9 m, uniform field 4 T, see Fig. 7a) powered up to 20 kA with a total stored electromagnetic energy of 2.6 GJ and cooled at 4.5 K by an indirect method greatly simplifying the cryostat design. The helium flow in the cooling channels is driven by a thermo-siphon effect [13]. CMS uses a single helium refrigerator providing non-isothermal cooling for current leads and thermal shield in addition to base-load isothermal refrigeration at 4.5 K for the magnets. The total cooling capacity of this plant is 1.6 kW at 4.5 K.

ATLAS is based on a "thin" central solenoid (length 5.3 m, inner diameter 2.4 m, uniform field of 2 T) surrounded by a toroid consisting of three separate magnets, the barrel and two end-caps, generating a toroidal field in a cylindrical volume (length 26 m, external diameter 20 m, see Fig. 7b) covering the entire ATLAS detector. All these magnets, with the exception of the central solenoid, are powered up to 20 kA and the total stored electromagnetic energy is 1.8 GJ. The superconducting magnets of ATLAS are cooled at 4.5 K. For the solenoid, the helium flow in the cooling channels is driven by a thermo-siphon effect, whilst for the toroids the two-phase helium mixture is forced by centrifugal pumps [14]. For ATLAS calorimetry, three large calorimeters (a barrel and two end-caps) cover a cylindrical structure of a length of 13 m and an external diameter of 9 m. The corresponding cryostats are filled with 45 m<sup>3</sup> and 2x19 m<sup>3</sup> of liquid argon. The calorimeters are operated at 87 K in sub-cooled conditions (to prevent bubble formation) by means of heat exchangers placed inside the liquid argon volumes and cooled by a two-phase flow of liquid nitrogen forced by centrifugal pumps [15]. ATLAS uses two helium and one nitrogen refrigerators [16] independent from each others and providing non-isothermal cooling for the current leads and thermal shield in addition to base-load isothermal refrigeration at 4.5 K for the magnets and 84 K for the calorimeters. The total cooling capacity of these plants is 8.7 kW at 4.5 K. The helium refrigerators have integrated liquid nitrogen/gaseous helium heat exchangers to provide 60 kW capacities for cooling the magnets from 300 K down to 100 K. Furthermore, ATLAS calorimeters need additional 30 kW capacity for the 300 K to 100 K cool-down provided by the internal heat exchangers cooled by liquid nitrogen.

The LHC will start colliding beams in 2008, and should operate for some 20 years.



**Fig. 7.** The LHC experiment: the CMS-solenoid (a) and the ATLAS barrel-toroidal magnets (b)

## V. THERMONUCLEAR FUSION RESEARCH: THE ITER PROJECT

The ITER reactor [17] enters its final design phase and will be constructed at Cadarache, France. The ITER mission is to demonstrate, in the framework of an international collaboration, the scientific and technological feasibility of fusion energy for peaceful purposes. To control the nuclear fusion, three conditions have to be combined: the plasma has to reach a sufficient level of density and temperature for respectively bringing enough particles into proximity and for giving them enough energy to fuse, and these levels have to be kept during a minimum confinement time required for fusion.

ITER is an experimental fusion reactor based on the "tokamak" concept (see Fig. 8) - a superconducting toroidal (doughnut-shaped) magnetic configuration in which the conditions for controlled fusion reactions of 500 MW are created and maintained. The overall plant comprises the tokamak, its auxiliary systems, and supporting plant facilities such as the cryogenic system.

The superconducting magnetic system is composed of 18 Nb<sub>3</sub>Sn toroidal-field coils producing a magnetic field of 5.3 T at 6.2 m-radius for the confinement and stabilization of the 837 m<sup>3</sup> plasma volume, 6 Nb-Ti poloidal-field coils for the positioning and shaping of the plasma and a six-module Nb<sub>3</sub>Sn central solenoid coil for inducing a 15 MA plasma current.

The main functions of the ITER cryogenic system [18] are to cool the superconducting magnets at 4.5 K and their current leads (40 to 68 kA). In addition, it has to cool and regenerate in the alternative way the 10 cryo-pumps at 4.5 K for ultra high vacuum pumping of the plasma vessel cryostat. Finally, the cryogenic system has to cool the 80 K thermal shields and small users (pellets, gyrotrons, diagnostics).

The ITER cryogenic system design includes a liquid helium plant of 65 kW at 4.5 K equivalent capacity including 0.16 kg/s of helium liquefaction for cooling both the current leads (0.1 kg/s) and the cool-down of vacuum cryo-pumps (0.06 kg/s). In addition, a 950 kW nitrogen plant is combined with an 80 K helium loop for cooling the ITER thermal shields. Due to the large level of dynamic heat load coming from the plasma and from the baking of the plasma chamber, a turn-down capacity of 3 is required\*. Moreover, the heat pulses

\* Turn-down capacity: ratio between the installed capacity and the minimum required capacity.

coming from the plasma have to be buffered in order to keep the cryoplants running at constant capacity. The helium inventory in the system is 20 tons. A cryogenic distribution system is composed by long and complicated cryogenic transfer lines, and several cold boxes housing either centrifugal cold compressors and circulating pumps and valves. The construction license is scheduled for 2008, the tokamak assembly should start in 2012 and the first plasma is foreseen by the end of year 2016.

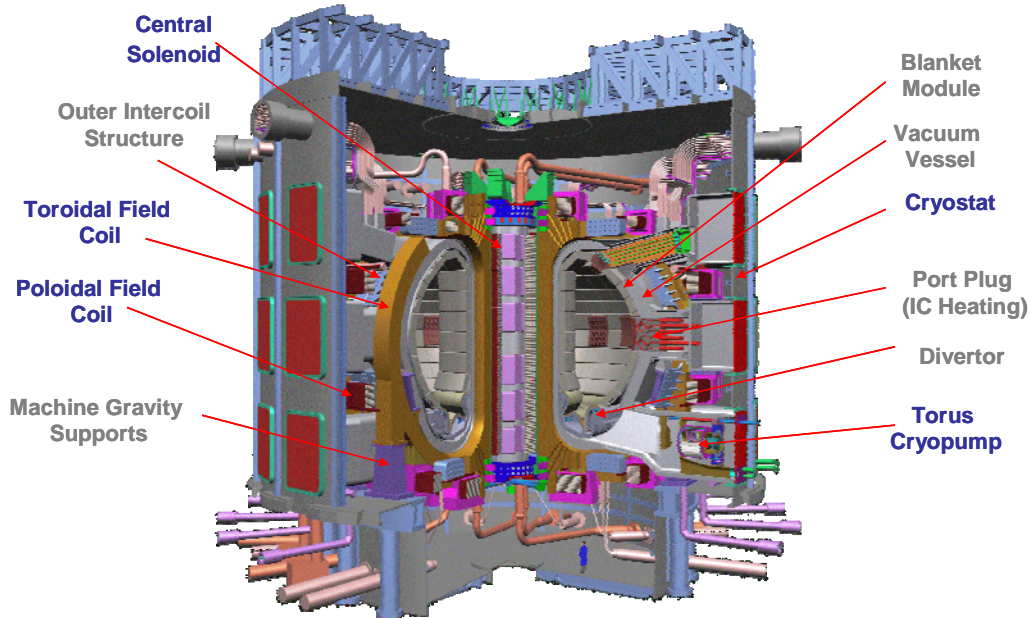

Fig. 8. The ITER Tokamak

## VI. PARTICLE PHYSICS AT THE ENERGY FRONTIER: FUTURE SYSTEMS

### A. The International Linear Collider (ILC)

Complementary to the LHC for making precision measurements in the TeV energy range is the International Linear Collider (ILC), presently under study by a world-wide collaboration organized through the Global Design Effort [19]. This machine is an electron-positron collider with beam energy of 250 GeV, later to be upgraded to 500 GeV. Its main subsystems will be two 11 km long linear accelerators (see Fig. 9a), using some 16,000 superconducting rf cavities made of Nb, which should operate at 1.3 GHz in saturated baths of superfluid helium at 2 K. To contain the length of the machine, an ambitious goal of 31.5 MV/m for the operating gradient has been set, requiring studies and development of new materials (large-grain, single-crystal Nb for cavities), improved surface treatments and more efficient cavity geometries. The cavities will be installed in 12-m long cryomodules (See Fig. 9b) such as developed for the TTF project at DESY (Germany), integrating all cryogenic pipework and ancillaries and assembled in cryogenic strings of 154 m. Cryogenic sectors of 2.5-km length will be individually served by helium refrigerators having the unit equivalent capacity of 20 kW at 4.5 K, including 3.7 kW at 2 K (See Fig. 10). The size of these machines is comparable to that of the LHC cryoplants. To cool both the linear accelerator and the damping rings, three 4.5 K and ten 2 K refrigerators would be required, with an overall installed equivalent capacity of 211 kW at 4.5 K, including 37 kW at 2 K [20]. The total helium inventory is estimated at 91 tons. The ILC Global Design Effort aims at conducting



focused R&D and producing a technical design report by the end of the decade, to permit approval and construction of ILC from 2010 onwards.

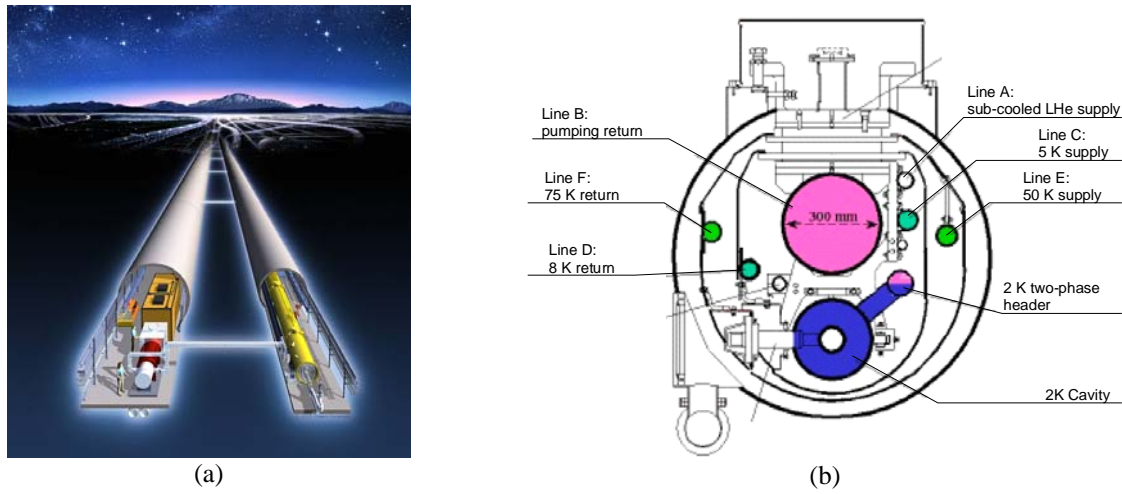

**Fig. 9.** The ILC study: the superconducting linear accelerator (a) and the cryomodule cross-section (b)

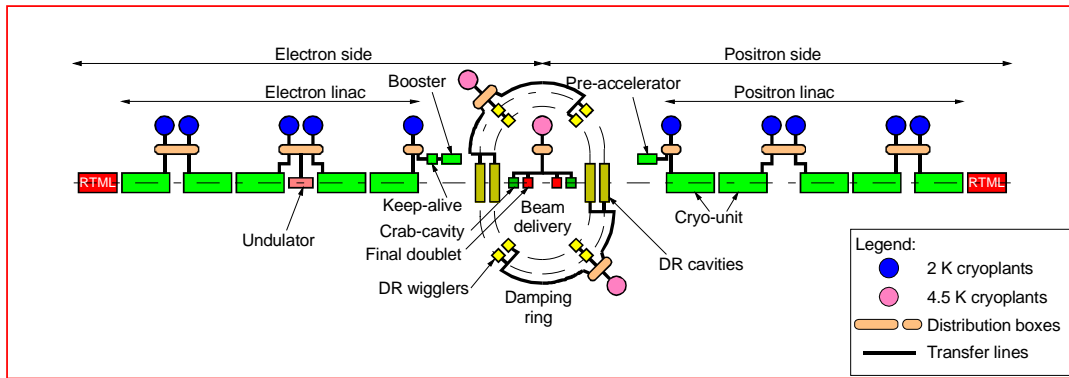

**Fig. 10.** ILC cryogenic architecture

*B. The LHC Luminosity Upgrade (SLHC)*

Over the LHC operation period of some 20 years, its luminosity will be gradually increased by upgrading the two high-luminosity collision regions [21] (new high-field, large aperture superconducting quadrupoles, so called the inner triplet, based on Nb-Ti and Nb<sub>3</sub>Sn) and the four superconducting accelerating radio-frequency cavity modules. The working temperature of these new insertions is still not set but given the large specific power to be dissipated in the coil winding, a sub-cooling of the cold masses around 2 K is envisaged. In this case, two 2 K cryoplants of equivalent capacity of 16 kW at 4.5 K including 5 kW at 2 K will be required to cool the new insertion magnets. In addition, the upgrade of the rf system will require a new 4.5 K cryoplant having an equivalent capacity of 7 kW at 4.5 K. The total installed power for this luminosity upgrade will be 39 kW at 4.5 K, including 10 kW at 2 K. The cryogenic distribution system will include 3 distribution boxes and about 500 m of compound transfer lines. Fig. 11 shows the cryogenic architecture of LHC luminosity upgrade. The cavity modules are labeled there by “RF”.

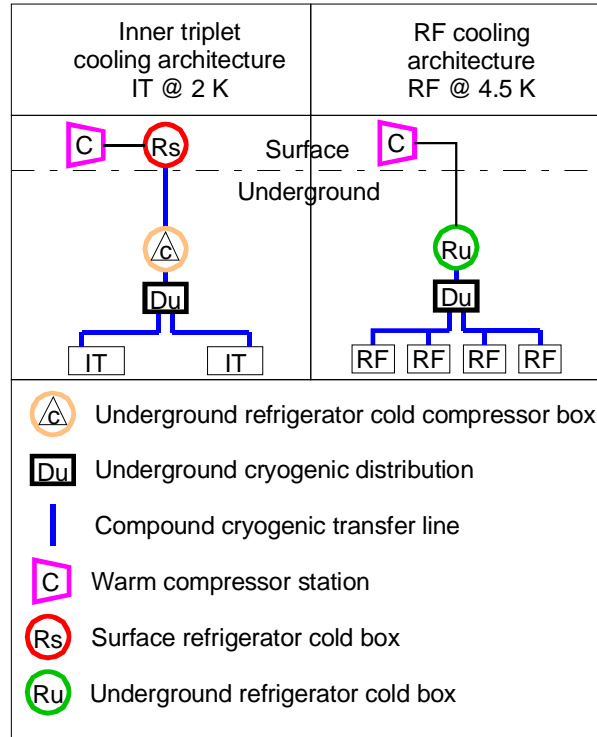

**Fig. 11.** Cryogenic architecture of LHC luminosity upgrade

### C. High-intensity Proton Linacs

In the framework of the upgrade of the injector chain at CERN, a Superconducting Proton Linac (SPL) is under preliminary study. The SPL is a high-intensity proton linear accelerator with a beam energy of 3.5 GeV and a beam power of 5 MW [22]. The rationale for using superconducting rf is, like for the Spallation Neutron Source [23], the energy efficiency. Out of the 430 m total length, 80 % would be equipped with 178 Nb superconducting cavities operating at 704 MHz with gradients up to 25 MV/m. The cavities would be housed in 24 cryomodules of a design similar to those of TTF operated at 2 K in saturated superfluid helium bath. The cryomodules would integrate all cryogenic distribution pipework and ancillaries and will be assembled in cryogenic strings of 130 m. The estimated equivalent capacity would be 16 kW at 4.5 K, including 4.5 kW at 2 K. Fig. 12 shows the SPL footprint on the CERN site.

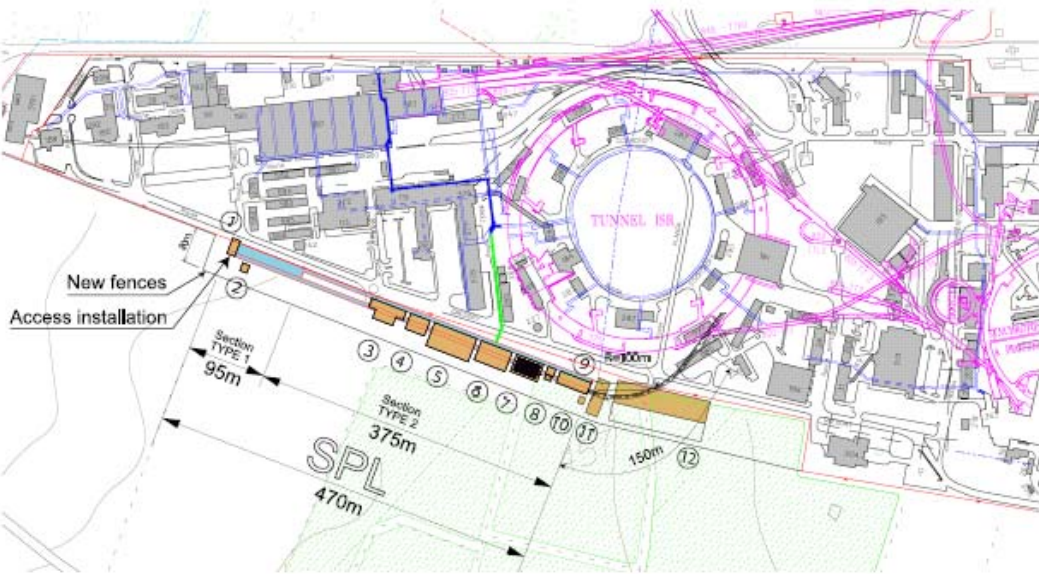

Fig. 12. The SPL footprint on the CERN site

*D. Nuclear Physics with Protons, Antiprotons and Ions*

The FAIR project, in preparation at GSI Darmstadt (Germany), is a vast complex of synchrotrons and storage rings using 1630 superconducting magnets of diverse types [24]. Particularly noteworthy are the pulsed superconducting magnets equipping the SIS100 and SIS300 synchrotrons, each with a circumference of 1.1 km. SIS100 will use 108 window-frame magnets of 2.1 T, fast ramping at 4 T/s, based on the Nuclotron design of Dubna (Russia). The coils will be made of Nb-Ti superconductor with a central cooling channel, cooled at 4.5 K by flow of two-phase helium. The 108 magnets of SIS300 will operate at 4.5 T with ramp rate of 1 T/s. They will be wound from Nb-Ti Rutherford cable conductor, with special polyimide insulation featuring cooling holes. Strings of magnets will be cooled by forced flow of supercritical helium at 4.5 K. Due to ramping losses, the cryogenic load will be strongly variable over time, with the dynamic term twice as large as the static load. Fig. 13 shows the different magnet types under definition. Two refrigerators, totaling a refrigeration equivalent capacity of 41.7 kW at 4.4 K, will feed the synchrotrons, storage rings and beam transfer lines. In view of the geographical dispersion of the user devices, some 1.7 km of cryogenic lines will be required [25]. The total helium inventory of FAIR is estimated to 11 tons. Fig. 14 shows the cryogenic layout of FAIR. Construction is expected to start in 2007, with possible staging in time of the different machines.

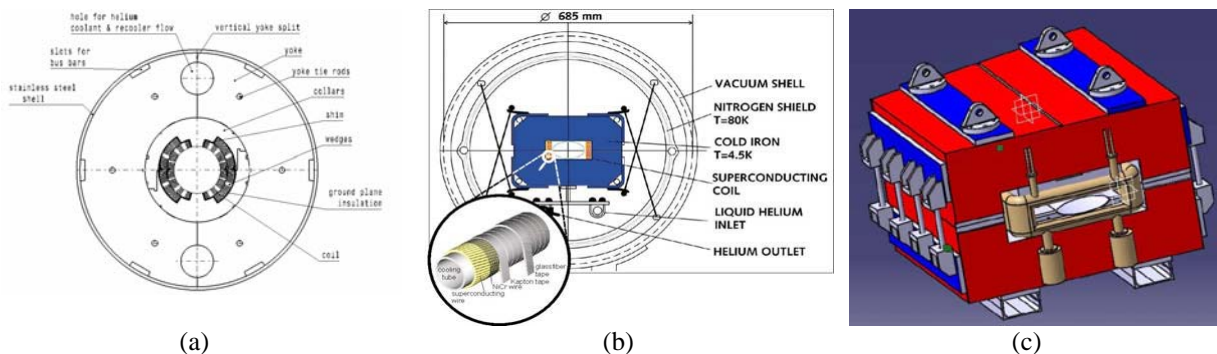
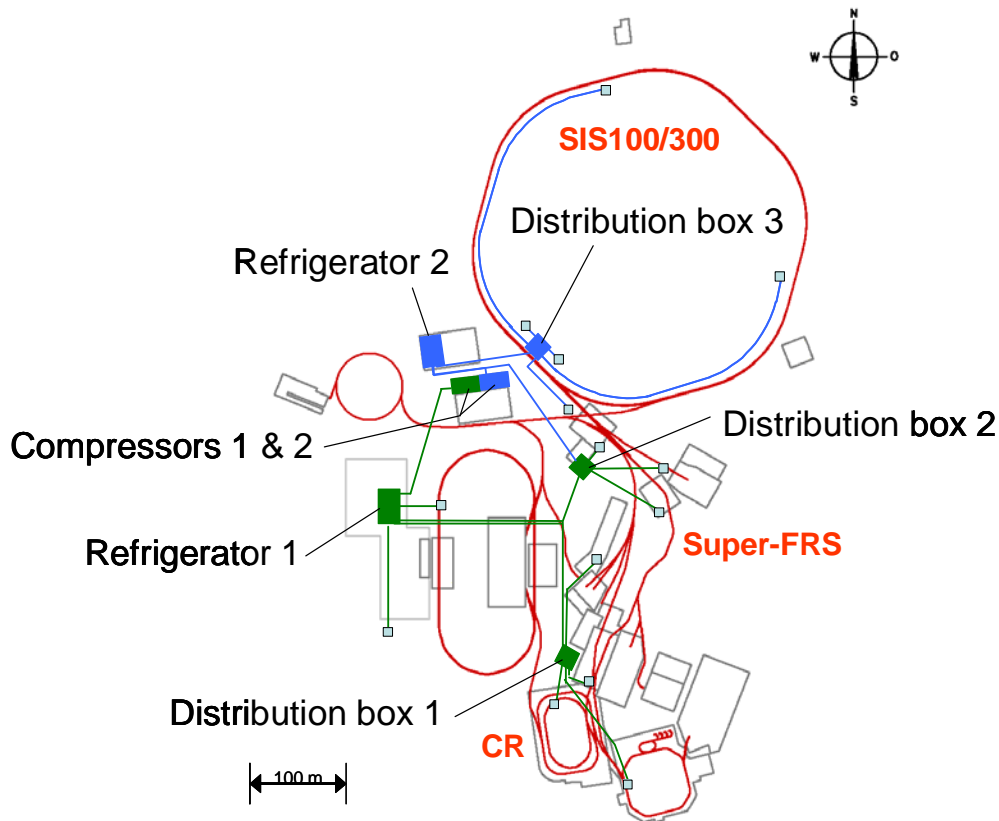

Fig. 13. Superconducting magnet for SIS300 (a), SIS100 (b), and Super-FRS and CR (c)



**Fig. 14.** Cryogenic layout of FAIR

#### *E. Ultra-fast, Intense X-rays to Probe Condensed Matter*

##### *1) The European X-ray Free-Electron Laser (E-XFEL)*

The European X-Ray FEL in preparation at DESY Hamburg (Germany) is a source of very brilliant, ultra-short (100 fs) pulses of X-rays down to 0.1 nm wavelength [26]. It will be based on a 17.5 GeV electron linear accelerator with an average beam power of 600 kW. The 1.7 km long linear accelerator will be equipped with 928 Nb superconducting rf cavities at 1.3 GHz with gradient of 23.6 MV/m. The cavities, housed in 116 cryomodules of 12 m length of the TTF type, will operate in static saturated superfluid helium at 2 K. The cryomodules, which include all cryogenic pipework and ancillary equipment, will be assembled in 146 m long cryogenic strings. The whole accelerator will be cooled by a central refrigerator with an equivalent capacity of 12 kW at 4.5 K, featuring 2.45 kW at 2 K with four stages of cold hydrodynamic compressors. The present HERA refrigerator could be used as back-up for improved availability of the E-XFEL. The total helium inventory of E-XFEL will be 8 tons. Construction is due to start in 2007 and first operation is expected by 2014.

Fig. 15 illustrates the E-XFEL project showing the cryomodules integrated in the tunnel (a), the cryogenic architecture (b), and the refrigerator process scheme (c).

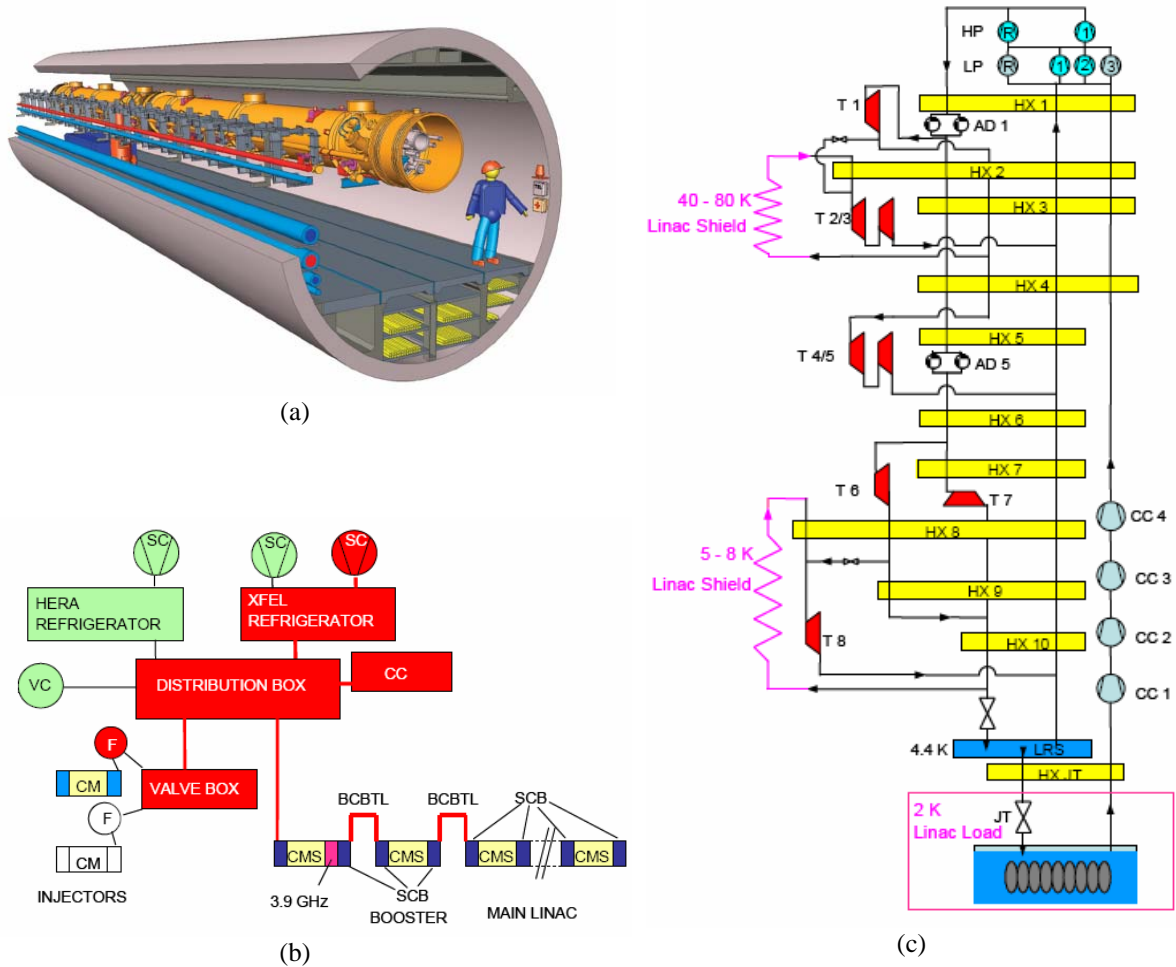
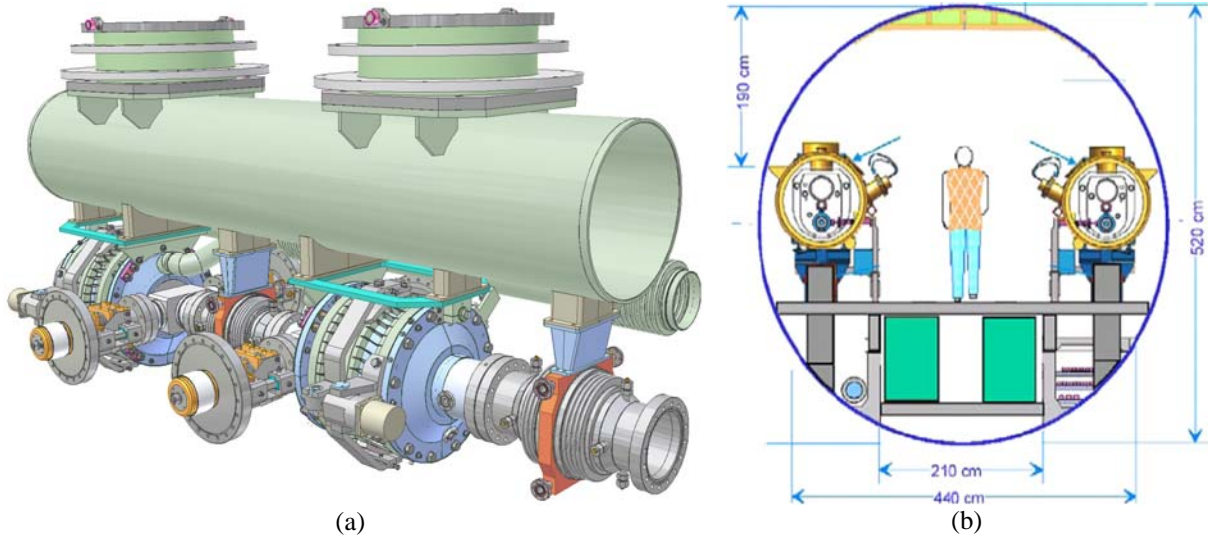

**Fig. 15.** The E-XFEL project: the cryomodules integrated in the tunnel (a), the cryogenic architecture (b) and the refrigerator process scheme (c)

## 2) The Energy Recovery Linacs (ERLs)

Energy recovery linacs (ERLs) are under study at several laboratories [27]. The Cornell (USA) project is based on a 5 GeV linear accelerator with a beam power of 500 MW, thus making energy recovery and acceleration efficiency an absolute necessity. It would use 390 Nb superconducting cavities at 1.3 GHz, operating in saturated superfluid helium at 1.8 K with gradient of 16 MV/m. Fig. 16 shows the superconducting cavity cold assembly and the cryomodules integrated in the accelerator tunnel. The refrigeration power needed is estimated at about 40 kW at 4.5 K equivalent capacity, including 10 kW at 1.8 K.

The G4LS project at Daresbury (UK) is a complex of FEL and ERL using 102 Nb superconducting cavities at 1.3 GHz, operating at 1.8 K with gradients of 15.5 MV/m. Fig. 17 shows the G4LS accelerator complex layout. The refrigeration power needed is about 14 kW at 4.5 K equivalent capacity, including 3.5 kW at 1.8 K [28]. The design and R&D work for 4GLS are presently funded.



**Fig. 16.** The ERL project at Cornell: the SRF cavity cold assembly (a) and the cryomodules integrated in the accelerator tunnel (b)

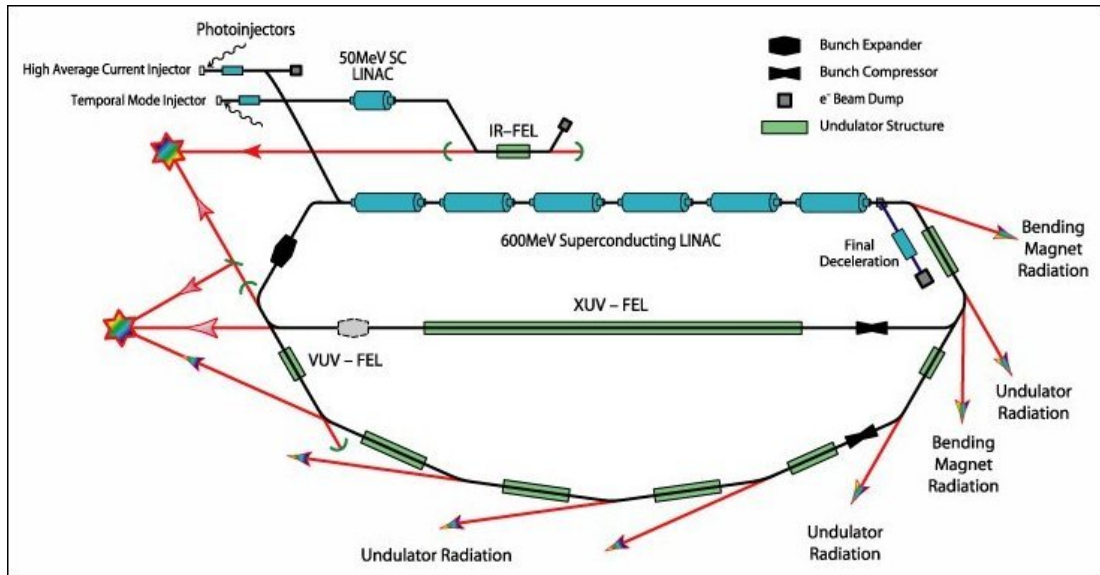

**Fig. 17.** The G4SL accelerator complex layout

## VI. CONCLUSION

Cryogenics constitutes key enabling technology of large superconducting systems. Thanks to development efforts during the past decades, this technology has now reached the required level. Standards for materials, devices, insulation techniques, cooling methods and cryogenic refrigeration are existing and industrially available. With the LHC and the development of superconducting rf systems, superfluid helium has become a medium of choice for boosting superconductor performance and cooling extended systems. Several projects under study, preparation or construction ensure a bright future for this technology. Fig. 18 summarizes the cryogenic capacity and the helium inventory of large cryogenic systems. For these projects, the equivalent cooling capacity is significant, as the projects under construction are

equivalent to the LHC cooling capacity and the projects under study are equivalent to two times the LHC capacity.

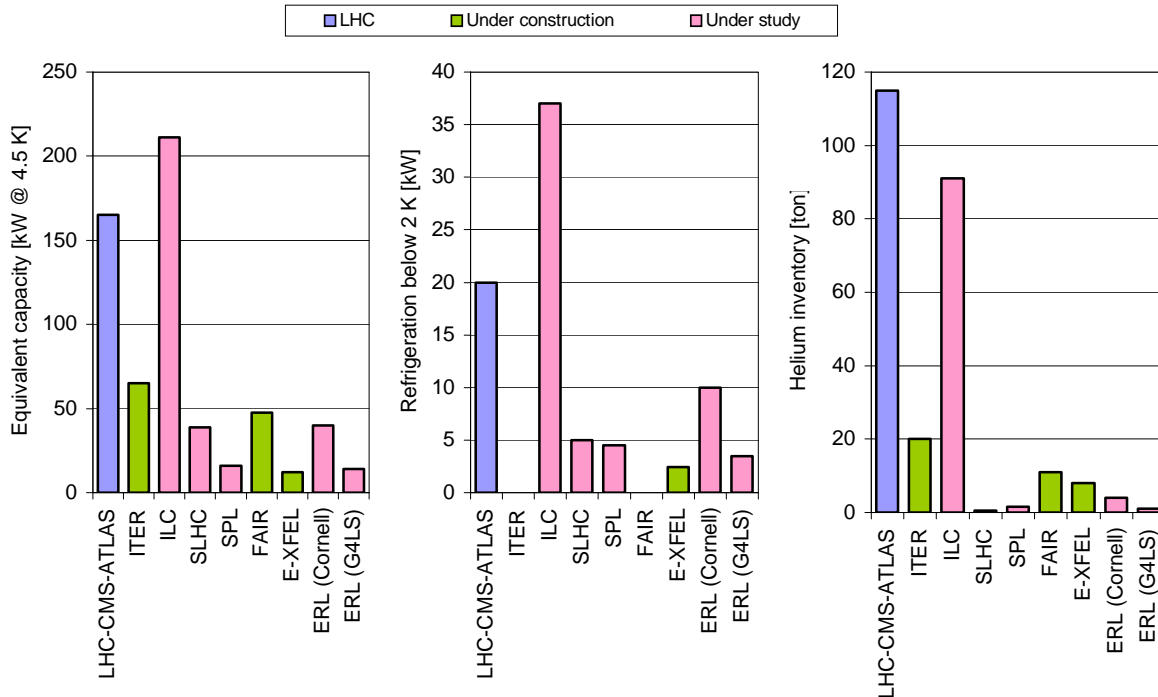

Fig. 18. Cryogenic capacity and helium inventory of large cryogenic systems

## REFERENCES

- [1] Ph. Lebrun, "Superconductivity and cryogenics for future high-energy accelerator", Proceedings of the 21th International Cryogenic Engineering Conference (ICEC 21), (2006) Praha, Czech Republic; <http://doc.cern.ch/archive/electronic/cern/preprints/at/at-2007-004.pdf>.
- [2] Ph. Lebrun *et al.*, "Cryogenics for particle accelerators and detectors", CERN-LHC-2002-011; Geneva, CERN, 5 Nov 2002; <http://doc.cern.ch/archive/electronic/cern/preprints/lhc/lhc-2002-011.pdf>.
- [3] S. Claudet, *et al.*, 2000, "Economics of large helium cryogenic systems: experience from recent projects at CERN", *Adv. Cryo. Eng.* 45A: p.1301-1308 <http://doc.cern.ch/archive/electronic/cern/preprints/lhc/lhc-project-report-317.pdf>.
- [4] L. Tavian, "Large cryogenic systems at 1.8 K", Proc. EPAC 2000, Vienna, Austria; <http://doc.cern.ch/archive/electronic/cern/preprints/lhc/lhc-project-report-412.pdf>.
- [5] LHC Design Report, CERN-2004-003, Geneva, Switzerland (2004); [http://documents.cern.ch/cgi-bin/setlink?base=cernrep&categ=Yellow\\_Report&id=2004-003-v3](http://documents.cern.ch/cgi-bin/setlink?base=cernrep&categ=Yellow_Report&id=2004-003-v3).
- [6] L. Rossi, "Superconducting magnets for the LHC main lattice", *IEEE Trans. Appl. Supercond.* 14 (2004) 153-158 ; <http://doc.cern.ch/archive/electronic/cern/preprints/lhc/lhc-project-report-718.pdf>
- [7] Ph. Lebrun, "Cryogenics for the Large Hadron Collider, IEEE Trans". *Appl. Supercond.* 10 (2000) 1500-1506 ; <http://preprints.cern.ch/cgi-bin/setlink?base=preprint&categ=cern&id=LHC-Project-Report-338>.
- [8] S. Claudet, "Recent progress in power refrigeration below 2 K for superconducting accelerators", Proc. PAC 2005 Knoxville, USA; <http://doc.cern.ch/archive/electronic/cern/preprints/at/at-2005-012.pdf>.
- [9] F. Barbier *et al.*, "Manufacturing and installation of the compound cryogenic distribution line for the LHC", Proceedings of the 21th International Cryogenic Engineering Conference (ICEC 21), (2006) Praha, Czech Republic, ISBN 978-80-239-883.
- [10] A. Ballarino, "HTS current leads for the LHC magnet powering system", *Physica C* 372-376 (2002) 1413-1418; <http://doc.cern.ch/archive/electronic/cern/preprints/lhc/lhc-project-report-608.pdf>.
- [11] ATLAS collaboration, ATLAS Technical Proposal, CERN/LHCC/94-43, (1994) Geneva, Switzerland; <http://documents.cern.ch/cgi-bin/setlink?base=generic&categ=public&id=cer-0212025>
- [12] CMS collaboration, CMS Technical Proposal, CERN/LHCC/94-38, (1994) Geneva, Switzerland;

- [13] D. Delikaris *et al.*, “The Cryogenic System of the Superconducting Solenoid Magnet of the CMS Experiment”, MT-15 Proceedings, (1997) Beijing, pp.1230-1233;  
<http://doc.cern.ch/archive/electronic/cern/preprints/lhc/lhc-project-report-165.pdf>.
- [14] R. Pengo *et al.*, “Test Results of a 1.2 kg/s Centrifugal Liquid Helium Pump for the ATLAS Superconducting Toroid Magnet System”, Proceedings of the 19th International Cryogenic Engineering Conference (ICEC 19), (2002) Grenoble, France;  
<http://doc.cern.ch/archive/electronic/cern/preprints/lhc/lhc-2002-013.pdf>.
- [15] J. Bremer, “The Cryogenic System for the ATLAS Liquid Argon Detector”, Proceeding 18th Int. Cryogenic Engineering Conference, (2000) Mumbai, India, pp. 219-222;  
<http://doc.cern.ch/archive/electronic/cern/preprints/lhc/lhc-project-report-393.pdf>
- [16] N. Delruelle *et al.*, “The Helium Cryogenic System for the ATLAS Experiment”, *IEEE Trans. Appl. Supercond.*, **10** (1999) 1511-1513; <http://www.ieee.org/web/conferences/home/index.html>.
- [17] R. Aymar *et al.*, “The ITER design”, *Plasma Phys. Control. Fusion* **44** (2002) 519-565;  
<http://iopscience.iop.org/0741-3335/44/5/304/?ejredirect=iopscience>.
- [18] V. Kalinin *et al.*, “ITER cryogenic system”, *Fusion Eng. Design* **81** (2006) 2589-2595;  
[http://www.sciencedirect.com/science?\\_ob=ArticleURL&\\_udi=B6V3C-4KTMTWH-1&\\_user=107896&\\_coverDate=11%2F30%2F2006&\\_rdoc=1&\\_fmt=&\\_orig=search&\\_sort=d&\\_view=c&\\_acct=C000008398&\\_version=1&\\_urlVersion=0&\\_userid=107896&md5=fc03a1e87e4aba9b0763afc22051ae64](http://www.sciencedirect.com/science?_ob=ArticleURL&_udi=B6V3C-4KTMTWH-1&_user=107896&_coverDate=11%2F30%2F2006&_rdoc=1&_fmt=&_orig=search&_sort=d&_view=c&_acct=C000008398&_version=1&_urlVersion=0&_userid=107896&md5=fc03a1e87e4aba9b0763afc22051ae64).
- [19] ILC Baseline Configuration Document; [http://www.linearcollider.org/wiki/doku.php?id=bcd:bcd\\_home](http://www.linearcollider.org/wiki/doku.php?id=bcd:bcd_home).
- [20] T. J. Peterson J. *et al.*, “ILC cryogenic system reference design”, Proceedings of CEC’07 conference, Chattanooga (USA).
- [21] W. Scandale, “Possible scenarios for the LHC luminosity upgrade”, IFAE 2005: XVII Incontri de Fisica delle Alte Energie; 17th Italian Meeting on High Energy Physics. *AIP Conference Proceedings*, **794** (2005), 15-19.
- [22] R. Garoby, “The SPL at CERN”, Proc. ICFA-HB2004, Bensheim, Germany, *AIP Conf. Proc.* **773** (2005) 239-243; <http://doc.cern.ch/archive/electronic/cern/preprints/ab/ab-2005-007.pdf>.
- [23] C. Rode *et al.*, “The SNS superconducting linac system”, Proc. PAC 2001, (2001) Chicago, USA
- [24] FAIR Baseline Technical Report; <http://www.gsi.de/fair/reports/btr.html>.
- [25] M. Kauschke, C.H. Schroeder, Y. Xiang, Cryogenic distribution system for FAIR, Proceedings of the 21<sup>th</sup> International Cryogenic Engineering Conference (ICEC 21), (2006) Praha, Czech Republic, ISBN 978-80-239-883.
- [26] The E-XFEL Technical design Report; [http://xfel.desy.de/tdr/index\\_eng.html](http://xfel.desy.de/tdr/index_eng.html).
- [27] I. Bazarov, “Overview of energy recovery linacs”, Proc. PAC 2005 Knoxville, USA.
- [28] S. Patalwar *et al.*, “Key cryogenic challenges in the development of the 4GLS”, Proceedings of the 21<sup>th</sup> International Cryogenic Engineering Conference (ICEC 21), (2006) Praha, Czech Republic, ISBN 978-80-239-883.