



Engineering and Materials Challenges in ITER Toroidal Magnet system

ICEC 25-ICMC 2014 Conference,
Enschede, Netherlands, July 7-11, 2014

Arnaud Foussat
Toroidal Field Coils section leader
ITER Organisation, France.



Disclaimer: The views and opinions expressed herein do not necessarily reflect those of the ITER Organization



ICEC 25 – ICMC 2014 conference, July 7-11, Enschede, The Netherlands

Contributions

The author acknowledges the help from all contributors to the material presented :

- **ITER TF Magnet section (ITER)**, K. Hamada, S Koczorowski, R. Gallix, M. Gandel, K Seo, E. Carnacina, M. Lerest, C. Boyer, B. Martin, H Shiqian, *B. Lim, P. Libeyre, A. Devred, N. Mitchell. and help from ITER Organisation (IO)*,
- EUDA ITER magnet project team, A.Bonito-Oliva, B Bellesia, E. Boter, M. Cornelis, R. Harrison, D. Kleiner, H. Rajainmaki, from European Fusion for Energy (F4E)
- JADA ITER magnet project team, N. Koizumi, K. Matsui, T. Hemmi, M. Yamane, M Nakahira, from Japanese Domestic Agency (JADA)
- CERN MME-MM, S. Sgobba, S. Langeslag, S. Atieh, I. A. Santillana, J.M Dalin from European Center for Nuclear Research (CERN)





Outlines

- **ITER Tokamak Project and site**
- **Magnet System**
- **Toroidal Field coils design**
- **Engineering manufacture challenges**
- **Material development**
 - *TF coil case cryogenic material,*
 - *Electrical Joints material,*
 - *Helium inlets welds,*
 - *High Voltage feedthroughs insulation,*
 - *Composite precompression rings material*
- **Summary**

ITER Tokamak Project and site

- Magnet System
- Toroidal Field coils design
- Engineering manufacture challenges
- Material development
- Summary



ITER: The Way to Fusion Power

The ITER project represents the frontier in fusion energy generation, and will deliver an international scientific laboratory that demonstrates the feasibility of hydrogen fusion as a source of electricity in the 21st century.

Technical program objectives:

- Achieve **extended burn of D-T plasmas**, with steady state as the ultimate goal.
- **Integrate and test all essential fusion power reactor technologies and components.**
- Demonstrate **safety and environmental acceptability of fusion**
- **Integrated device answering all feasibility issues needed to define a future DEMO reactor** (for instance, the 14 MeV n-resistance for in-vessel components)

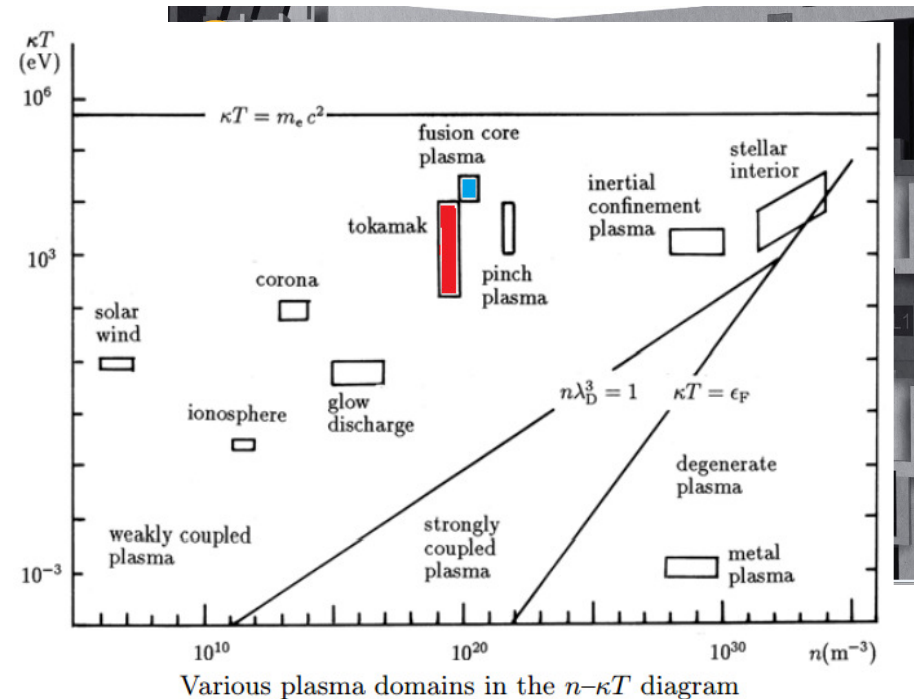

ITER: The Way to Fusion Power

The ITER project represents the frontier in fusion energy generation, and will deliver an international scientific laboratory that demonstrates the feasibility of hydrogen fusion as a source of electricity in the 21st century.

Technical program objectives:

- ❑ Achieve **extended burn of D-T plasmas**, with steady state as the ultimate goal.
- ❑ **Integrate and test** all essential fusion power reactor **technologies and components**.
- ❑ Demonstrate **safety and environmental** acceptability of fusion
- ❑ Integrated device **answering all feasibility issues** needed to define a future DEMO reactor (for instance, the 14 MeV n-resistance for in-vessel components)

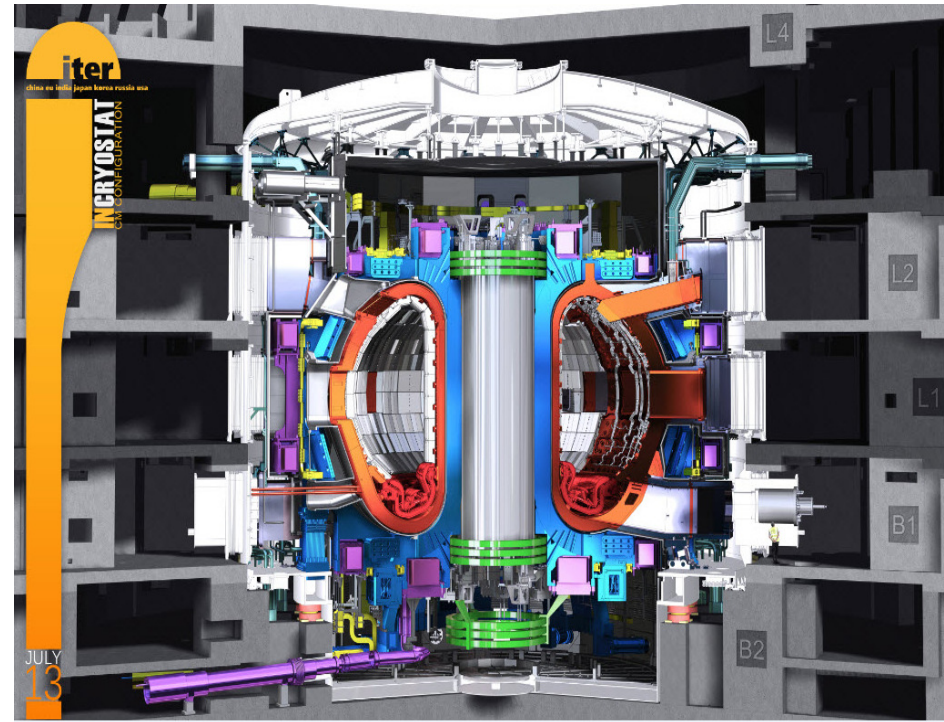



Over 60 years of research on tokamaks

Major Tokamak Facilities

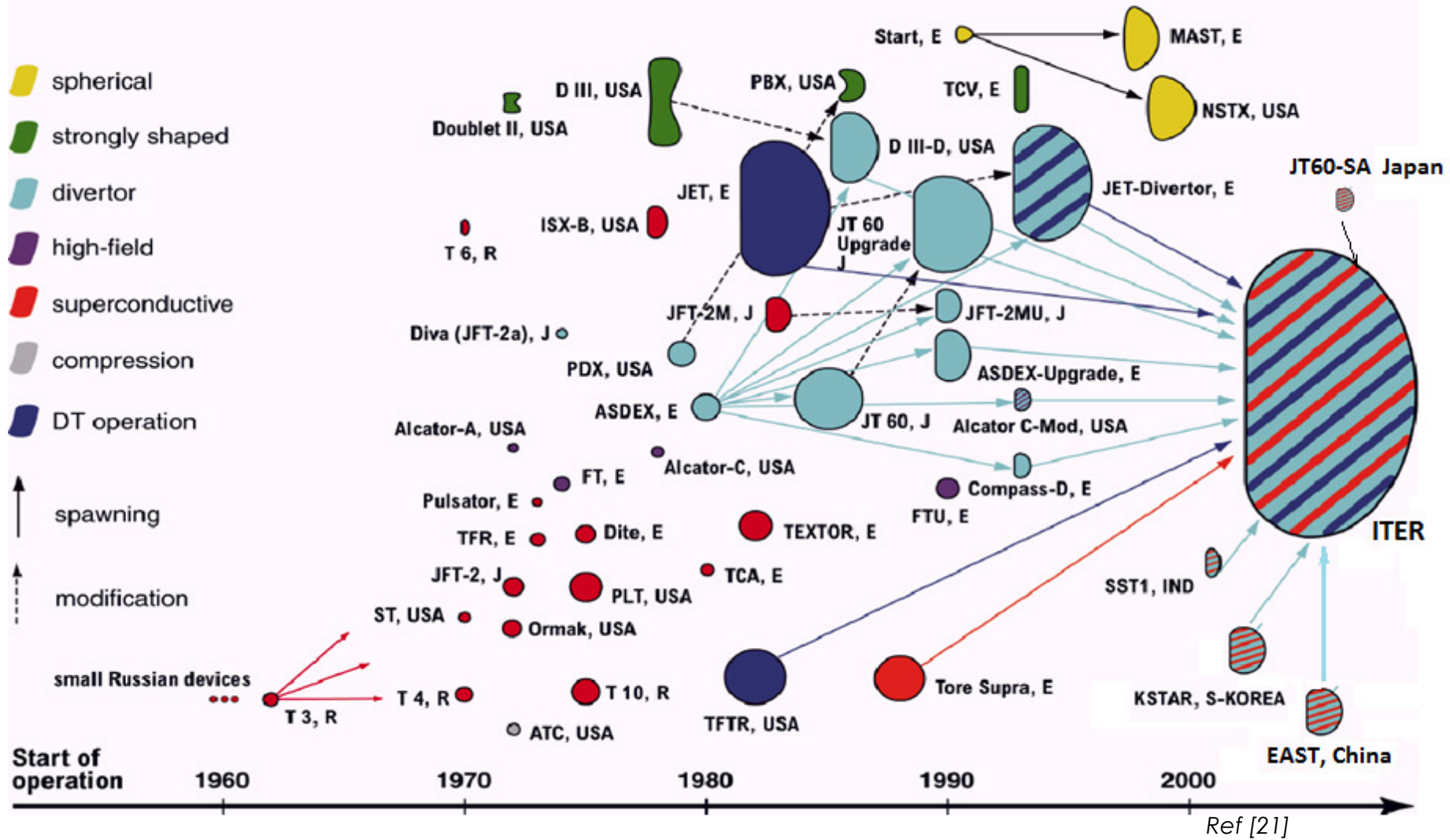

D-T Fusion reaction

Lawson criterion for ignition condition

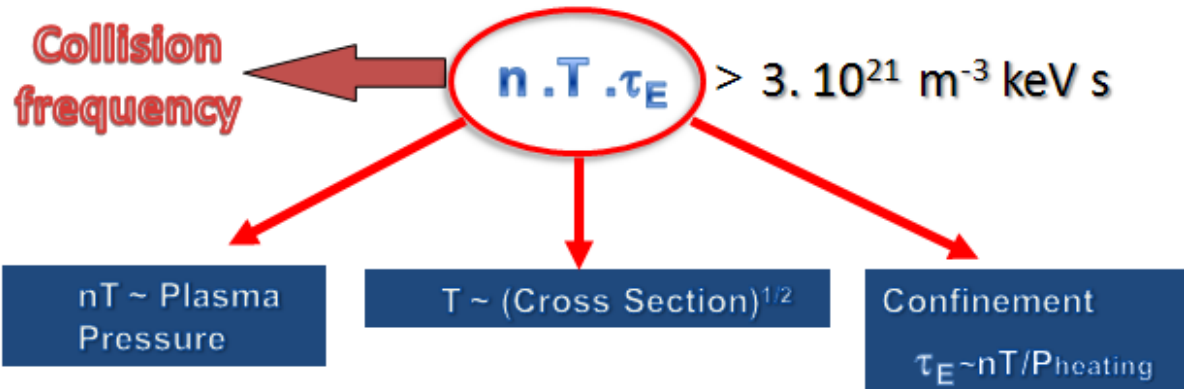

fusion energy gain, $Q \equiv \frac{P_{\text{fusion}}}{P_{\text{heat}}} = \frac{5 P_{\alpha}}{P_{\text{heat}}}$

α -heating fraction, $f_{\alpha} \equiv \frac{P_{\alpha}}{P_{\alpha} + P_{\text{heat}}} = \frac{Q}{Q+5}$

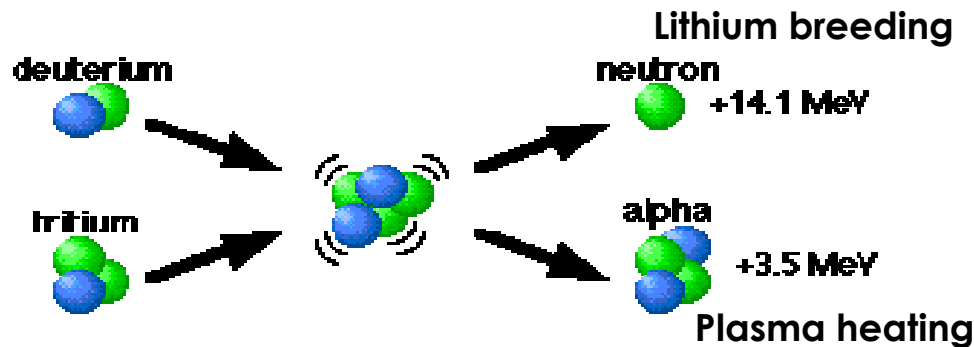

Fusion Reaction Cross-Sections

Particles Have Equal Momentum

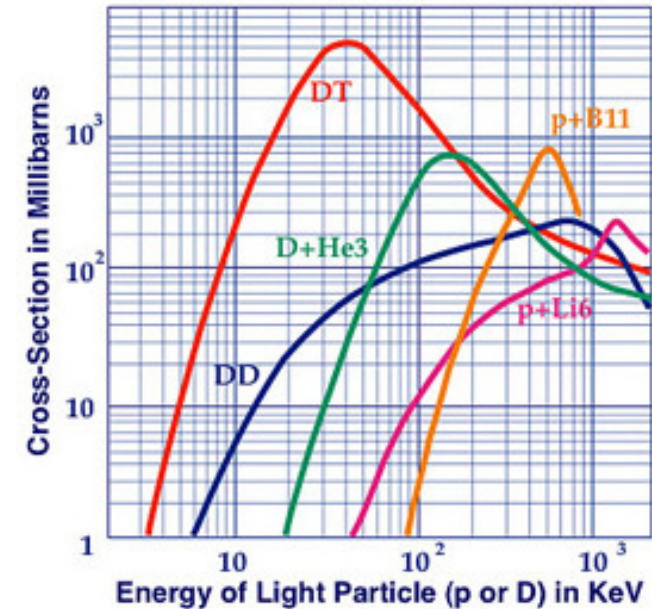

Largest D-T fusion cross section (5 barns @ center of mass 120 KeV)

Scientific Breakeven	$Q = 1$	$f_{\alpha} = 17\%$
Burning Plasma Regime	$Q = 5$	$f_{\alpha} = 50\%$
	$Q = 10$	$f_{\alpha} = 60\%$
	$Q = 20$	$f_{\alpha} = 80\%$
	$Q = \infty$	$f_{\alpha} = 100\%$

The Core of ITER Tokamak

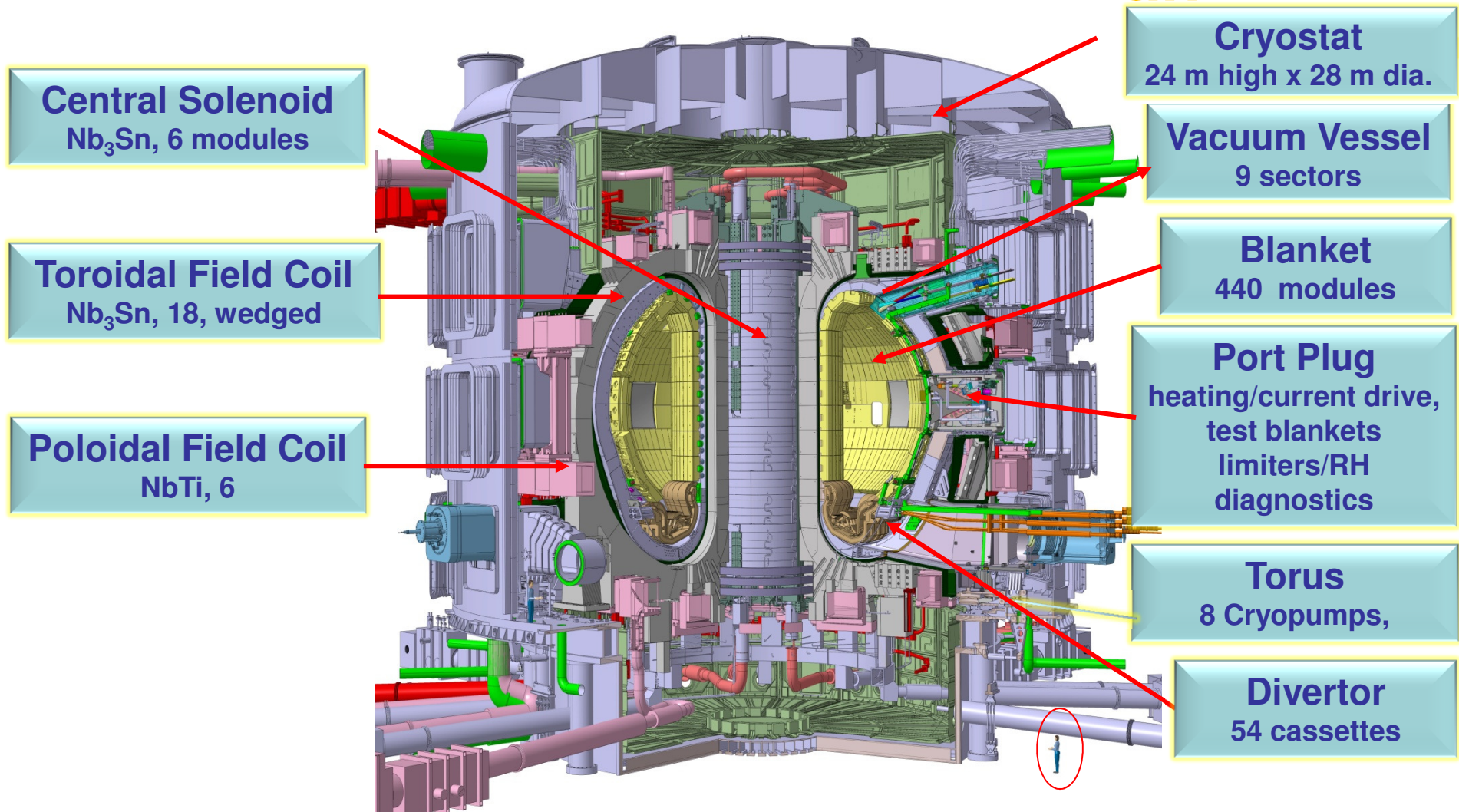

Machine mass: 23350 t (cryostat + VV + magnets)

Shielding, divertor and manifolds: 7945 t + 1060 port plugs

Magnet systems: 10150 t / Cryostat: 820 t, 28 m high, 29 m diameter



ITER key factors

Total fusion power: 500 MW

Fusion power/absorbed heating power ≥ 10

Installed auxiliary heating/current drive power: 73 MW

Pulse length: 300–3000 s

Average (14 MeV) neutron wall loading: 0.57 MW/m²

Plasma major radius R : 6.2 m

Plasma minor radius a : 2.0 m

Plasma volume: 836 m³

Plasma current: 15 MA

Toroidal field strength at 6.2 m radius: 5.3 T

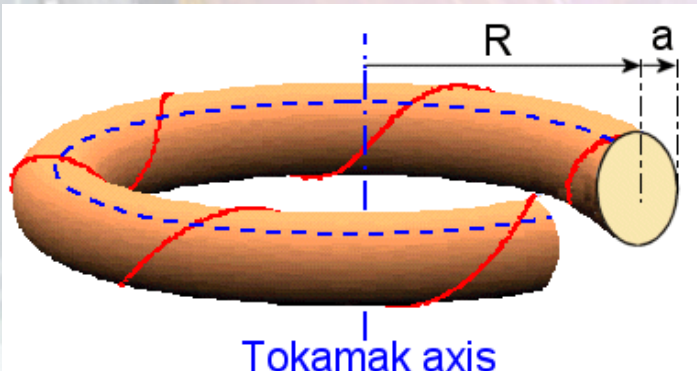

Ref [1,2]

Construction Site

Civil engineering is underway and French government has authorised the construction of Nuclear installation in November 2012



80 hectares platform
39 buildings

Aerial view

May 2014, ITER Organisation

Site construction progress

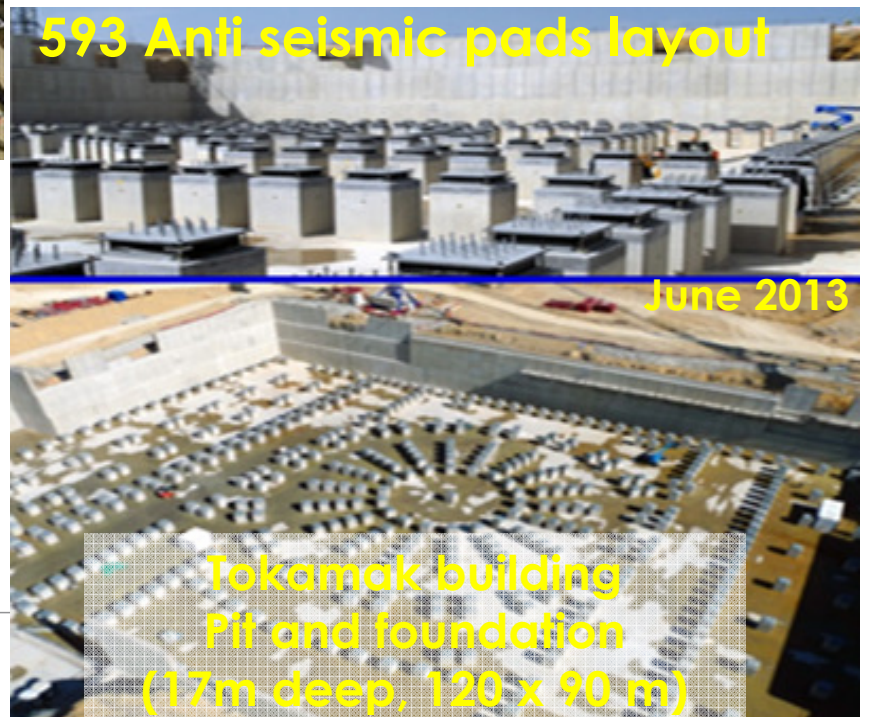
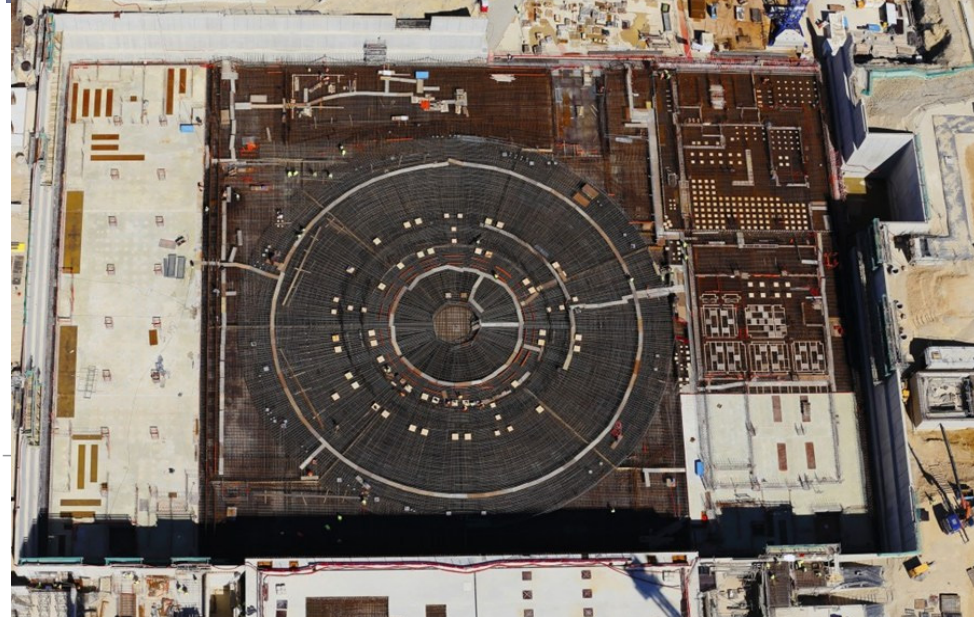



Global logistic on ITER Magnets

TF Coils - A Worldwide Collaboration

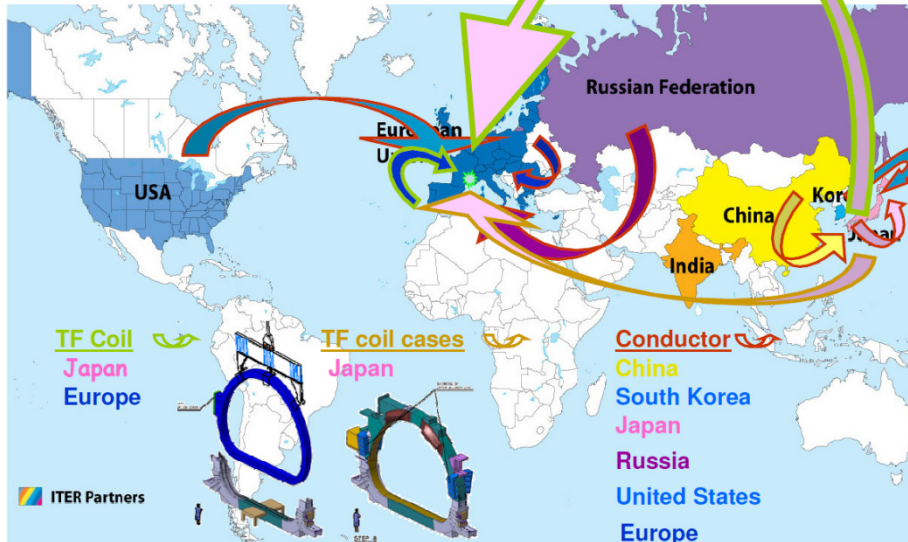

Worldwide supply of Magnets sub components from conductor to complete coils delivery to ITER site in France. Final transport from harbor over 104 kms.



- ITER Tokamak Project and site

Magnet System

- Toroidal Field coils design
- Engineering manufacture challenges
- Material development
- Summary



ITER Magnet System

The ITER magnet system is made of 48 different coils

- **18 Toroidal Field (TF) Coils,**
- 6 modules Central Solenoid (CS),
- **6 Poloidal Field (PF) Coils,**
- **9 pairs of Correction Coils (CCs).**

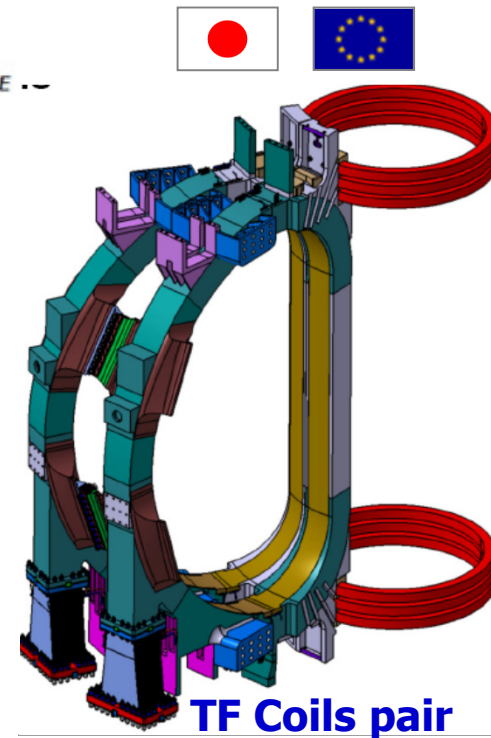
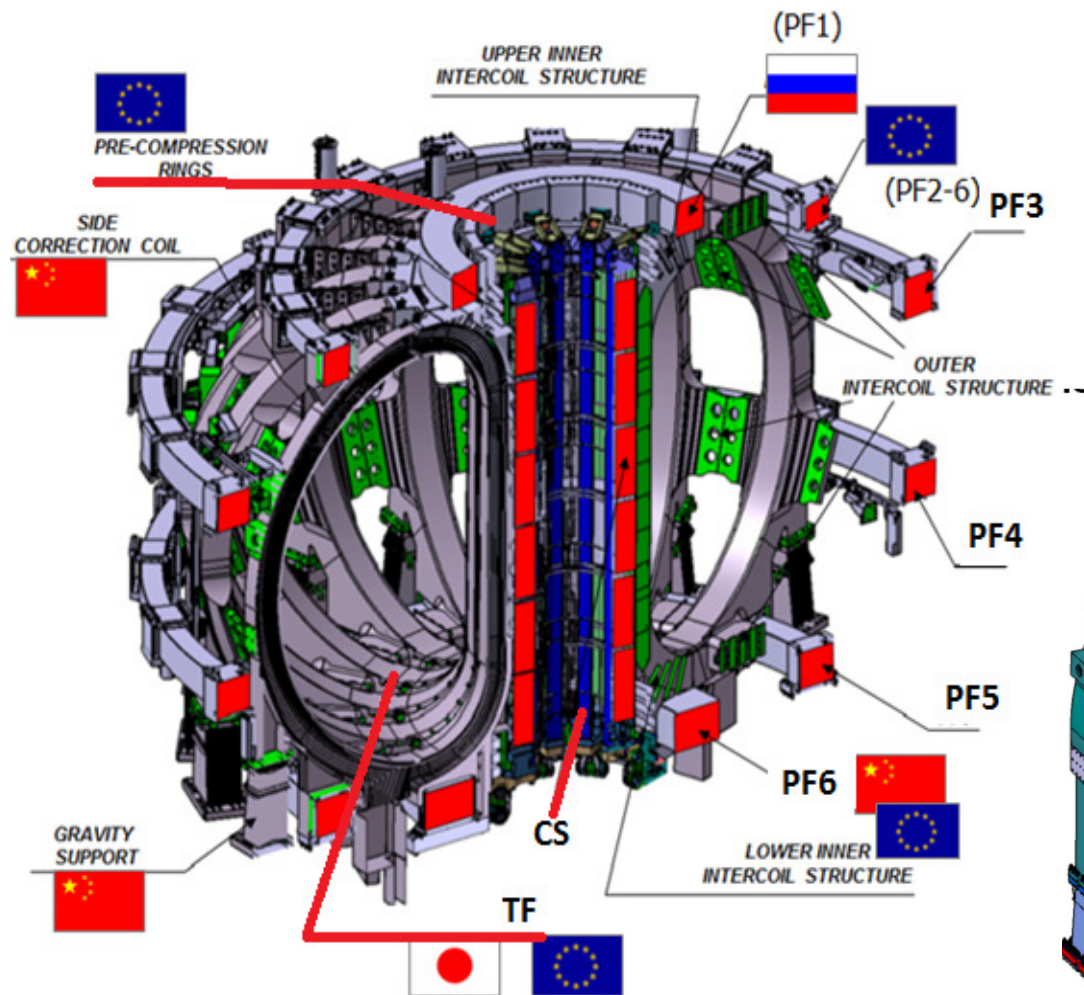

TF Coils pair

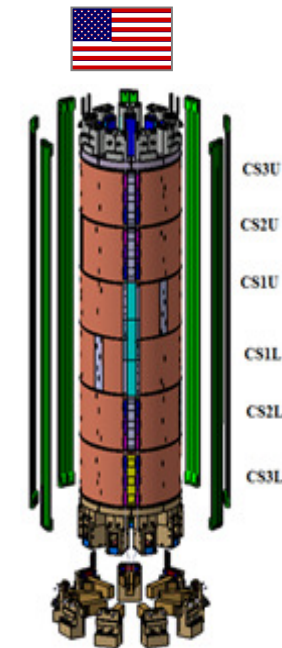

CS Coil Ref [3]



Why is the Magnetic system needed ?

- ❑ **TF Coils** are used for charged particles confinement in plasma, operate in steady mode
- ❑ **Central solenoid** drives the current in the plasma through transformer effect. (transient currents)
- ❑ **PF coils** are used to control radial position equilibrium of plasma, as well as for plasma shaping and vertical stability.
- ❑ **Correction Coils** are used to correct field harmonics errors especially caused by assembly tolerances

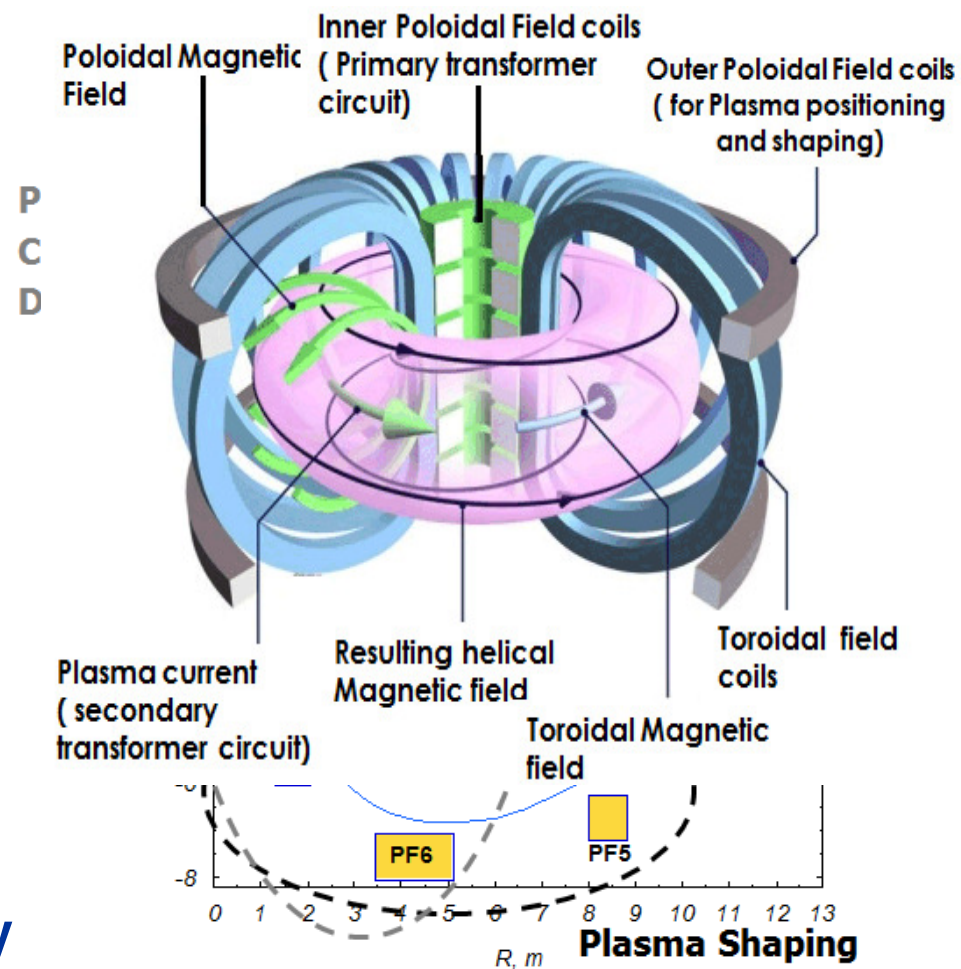

Why is the Magnetic system needed ?

- ❑ **TF Coils** are used for charged particles confinement in plasma, operate in steady mode
- ❑ **Central solenoid** drives the current in the plasma through transformer effect. (transient currents)
- ❑ **PF coils** are used to control radial position equilibrium of plasma, as well as for plasma shaping and vertical stability.
- ❑ **Correction Coils** are used to correct field harmonics errors especially caused by assembly tolerances

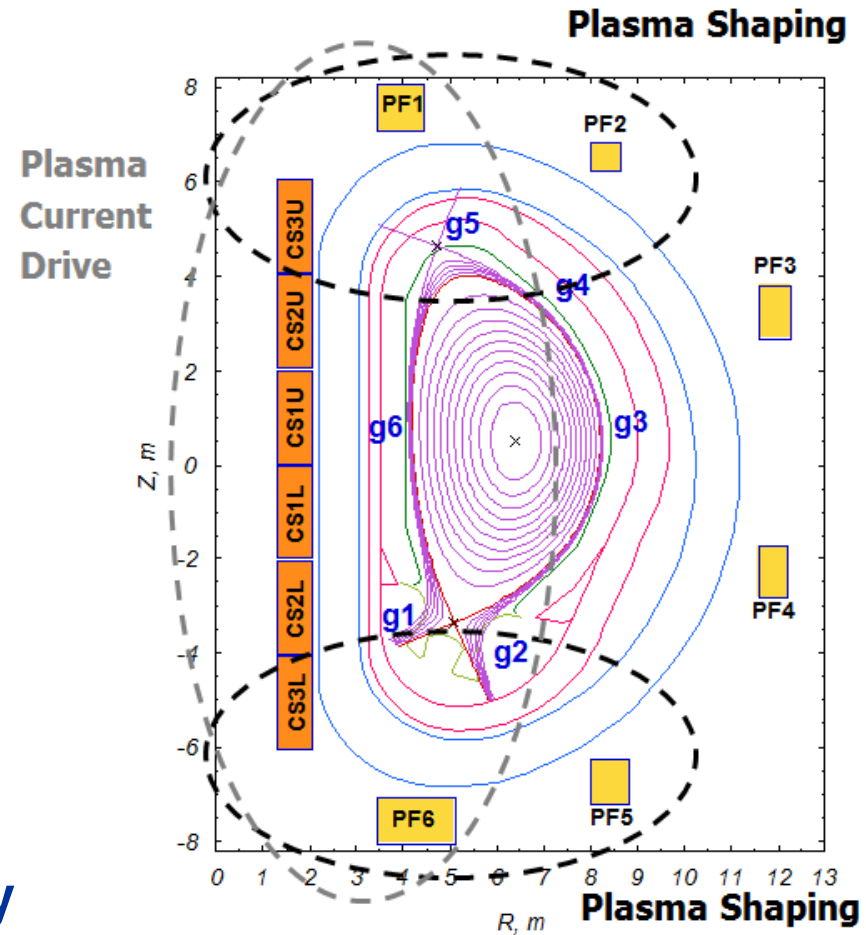

Overview of Feeder system

ITER magnets are supplied with current and supercritical LHe @ 0.6MPa by **31 Feeders**.

- The magnet Feeders include
 - **Nb–Ti CICC busbars**
 - **Bi-SCCO 2223 Ag-Au(5.4%) tapes HTS current leads.**

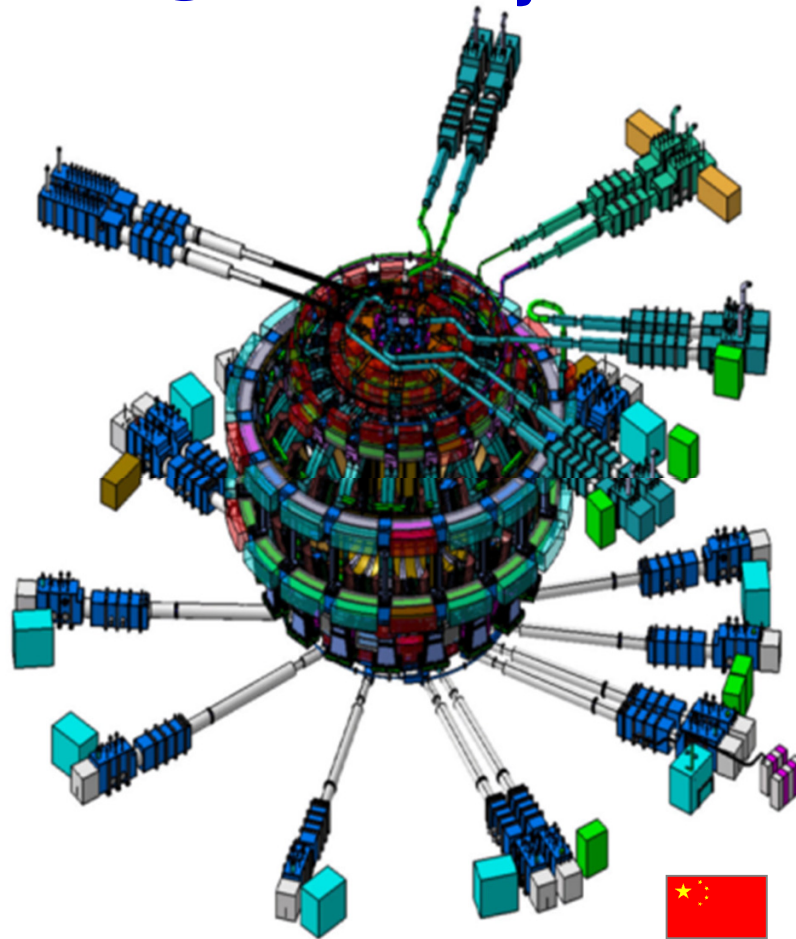

ITER Feeder System

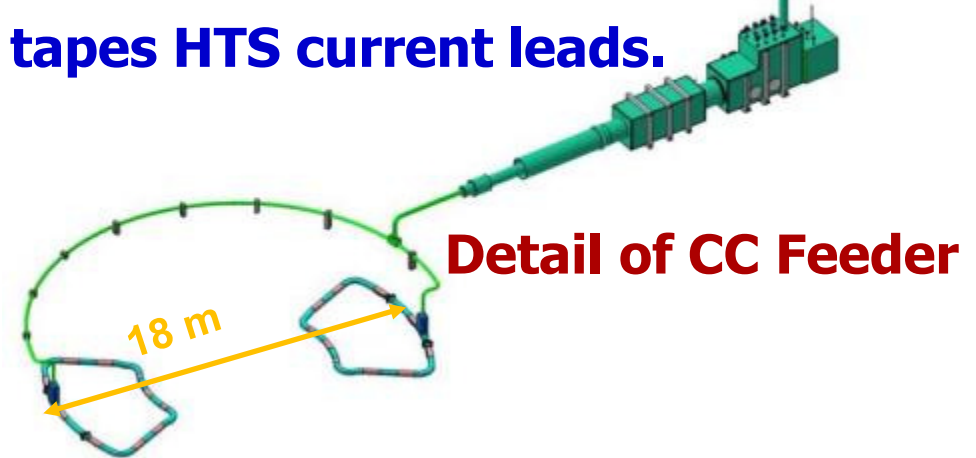

HTSC 68kA current leads



68 kA Trial Lead Developed by ASIPP

- **ITER Tokamak Project and site**
- **Magnet System**

Toroidal Field coils design

- **Engineering manufacture challenges**
- **Material development**
- **Summary**



ITER TF coil design features

- ❑ 18 TF superconducting coils cooled by supercritical LHe flow (4.5 K, 0.6 MPa)
- ❑ Nominal DC transport current of 68 kA
- ❑ Peak magnetic flux density of 11.8 T
- ❑ ~ 82 kms of Nb₃Sn Cable in Conduit Conductor (CICC)
- ❑ Stored magnetic energy of 41 GJ (comparison with 10.5 GJ in the 27 km tun of the Large Hadron Collider at CERN),
- ❑ Large 316LN stainless case structure encloses each winding pack, actively subcooled at 4.5K, and wedged to react large 410 MN centripetal e.m loads
- ❑ Overall weight ~ 5700 tons, 320 tons each

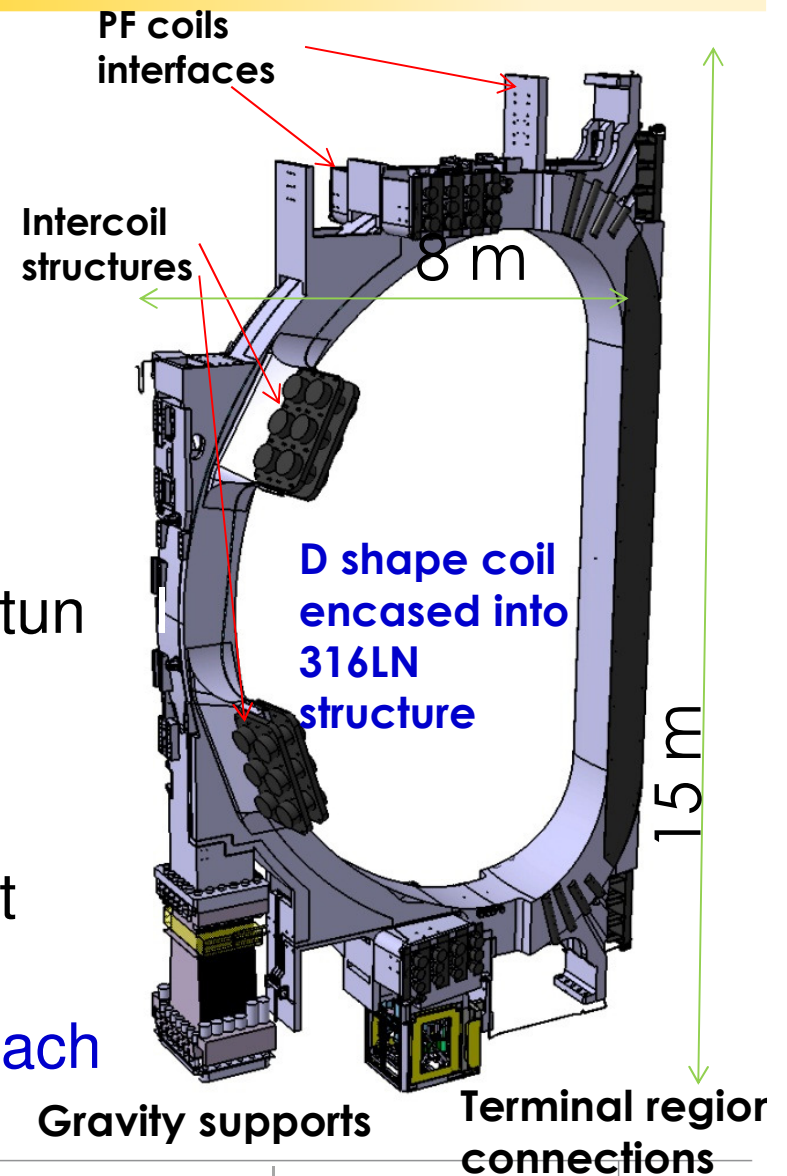



Toroidal Field Coils main components

- Fig.1 Wound conductors before heat treatment and insertion into radial



Fig.2 Radial plate



Fig.3 Winding pack formed of 7 radial plates containing conductors.

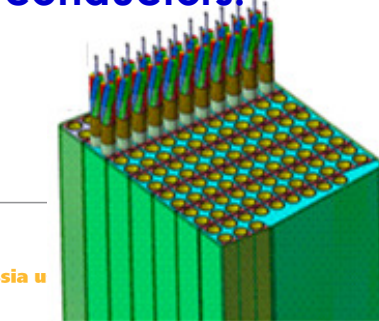

TF Winding Pack

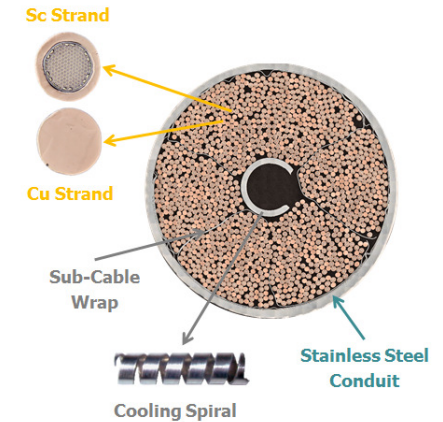
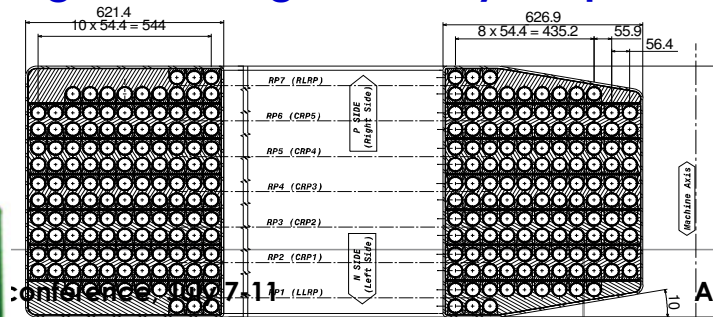

Fig. 5 Cable in conduit made of 900 Nb₃Sn strands in multistages with central channel into 316LN jacket

Fig. 4 Winding assembly shape



Arnaud Foussat

ands



Coil case operating stresses

Structural integrity of TF coils checked through extensive 3D finite element modelling at both operation and accidental conditions

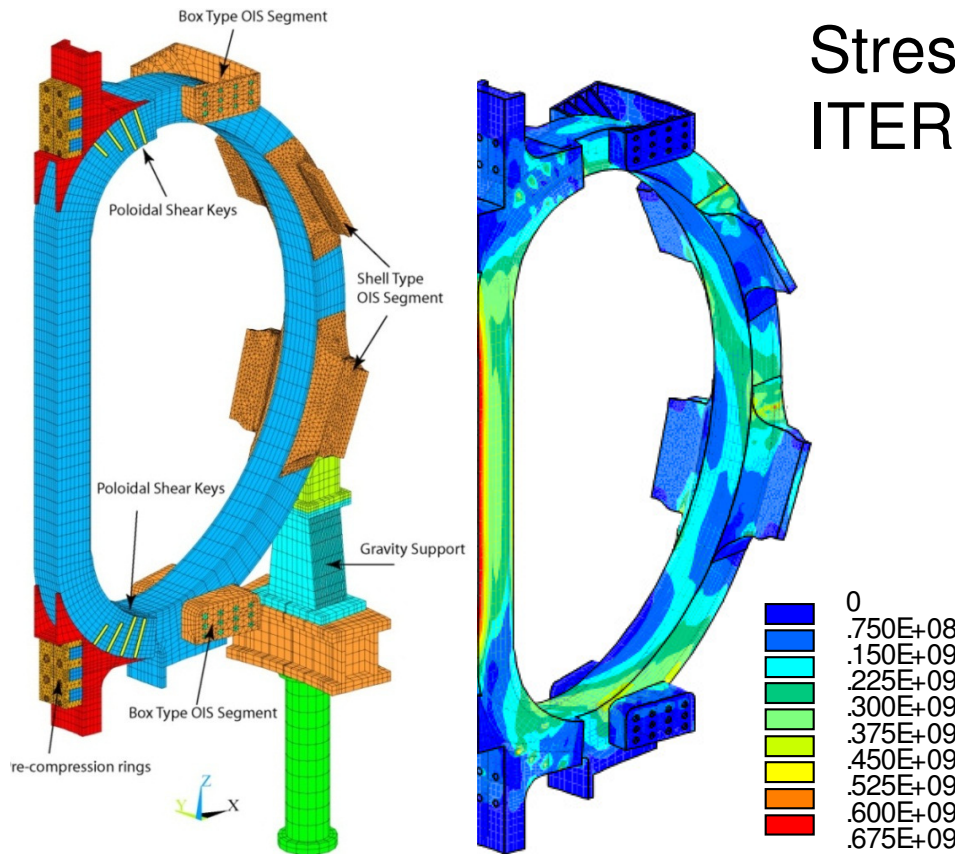

Stress assessments performed per ITER Magnet Structural Design Criteria

- Nominal steady **tensile operation hoop stress** in the poloidal direction (**in plane**) up to **680 Mpa** in straight leg.
- A **cyclic bending component** from the poloidal field (**out of plane**) up to **450 Mpa** stresses in outer leg.
- A **complex cyclic shear stress** at the keys and pins that link the TF coils together with **stress intensity variation of +/- 70 Mpa**.

Fig 1. Tresca Stress contour on TF structure at End of Burn plasma event.



Operating strain of TF coils

- The irreversible strain limit of Nb₃Sn strands plays a crucial role on the high field TF magnet operating design and influence on their manufacture stages.

In addition to intrinsic strain into strand, the cabling and operation conditions effects result in a differential strain of about -0.6 %, enough to cause ~ 25% loss of J_c, or 1-2 K on T_c in comparison to the strand performance

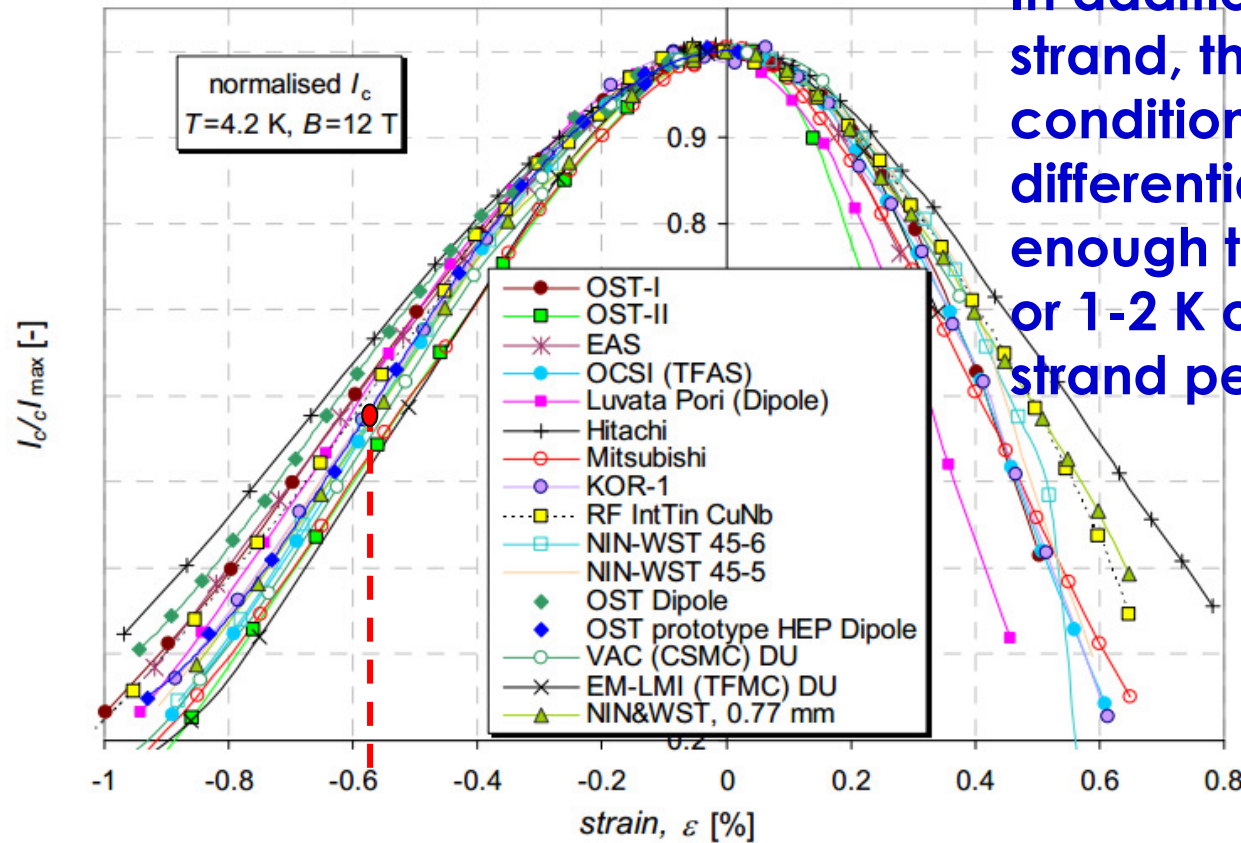

Fig 1. Reduced Ic versus intrinsic applied strain (credit from Twente Univ. [Paper IEEE Transactions on Applied Superconductivity](#) , 07/2009)

Ref [4,5]

- **ITER Tokamak Project and site**
- **Magnet System**
- **Toroidal Field coils design**

Engineering manufacture challenges

- **Material development**
- **Summary**



TF conductor manufacture process

TF CICC production process



Cable Insertion & Jacket Assembly

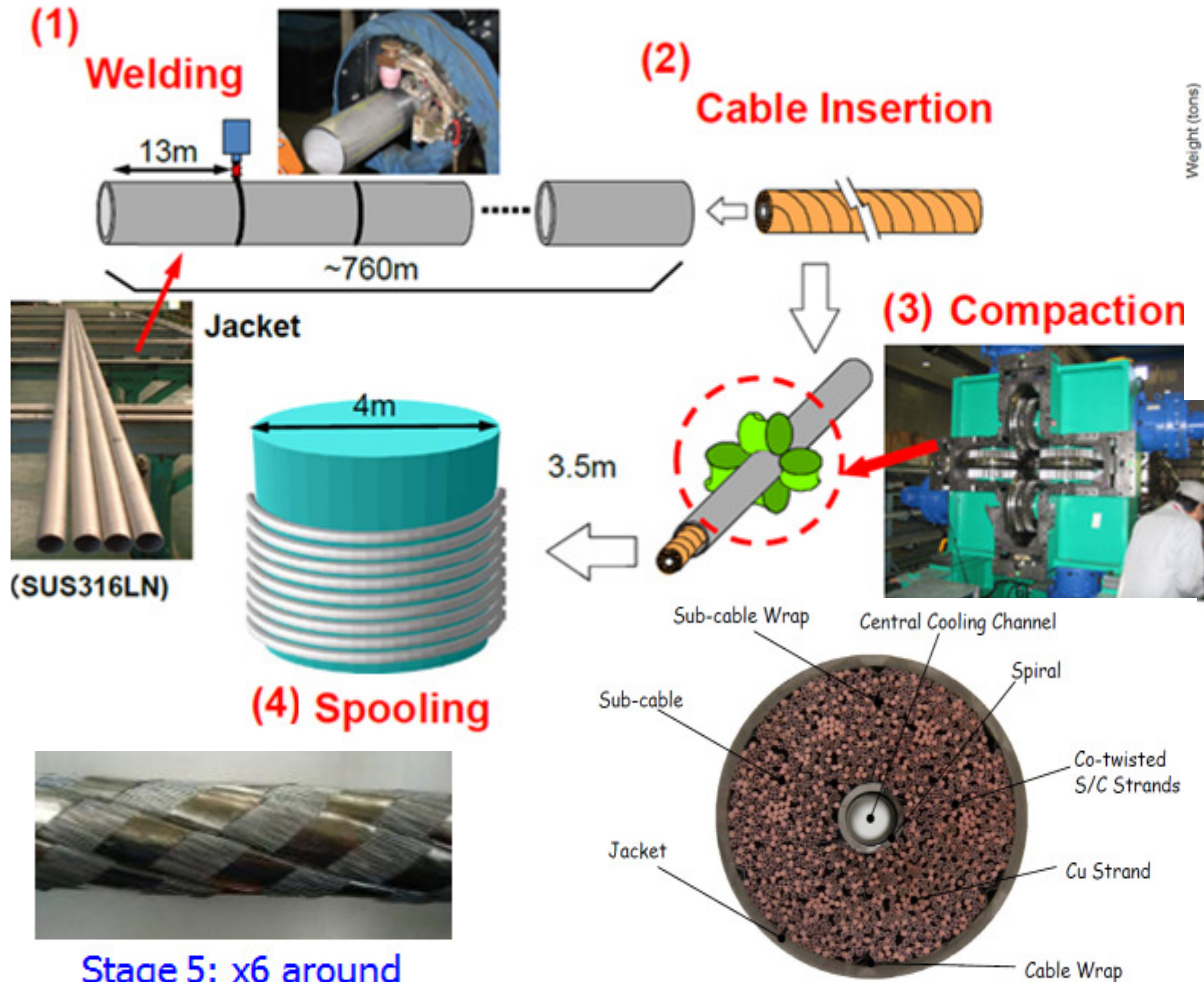

Stage 5: x6 around
Central cooling spiral
+ stainless steel wrap

(Courtesy of H. Matsuda, NSE)

TF strand production status

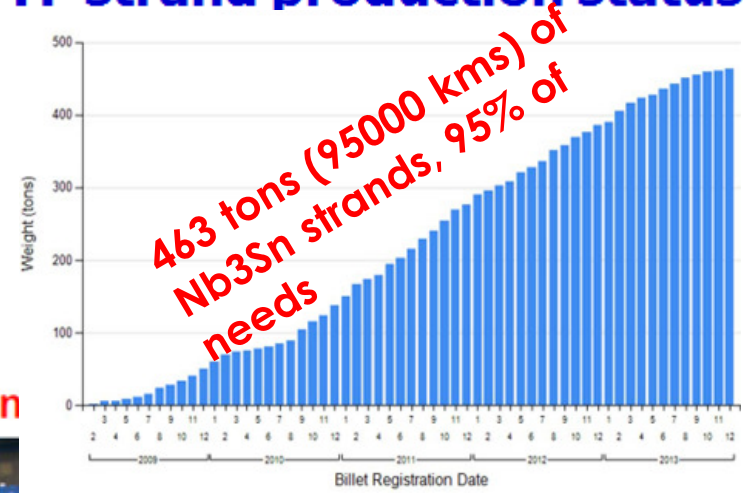

Billet Weight Distribution By DA

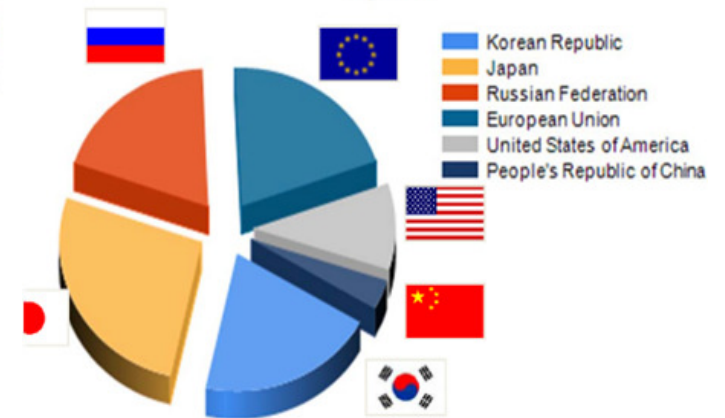

(Courtesy of G. Bevilard, IO)

ussia usa

Nb₃Sn CICC features

Iop (KA)	68
Type strand	Nb3Sn
Critical current at 12 T for Nb₃Sn strand @ 4.22 K	> 190A
A non copper (mm²)	235.33
A total (mm²)	508.32
Strand Diameter (mm)	0.82
Cu:nonCu Ratio	1.0
Number of SC Strands	900
Cable Pattern Core	((2sc+1cu)x3x5x5+core)x6 3x4 cu wires
Central spiral (mm)	9 x 7
Petal SS wrap	0.05 mm thick, 50% cover
Cable SS wrap	0.08 mm thick, 40% overlap
Void Fraction (%) in Annulus	33.1
Cable diameter (mm) / OD 316L jacket	40.5 / 43.7

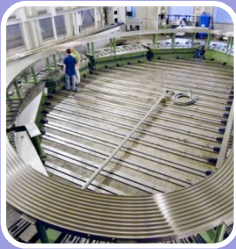

TF coil winding manufacture key features



Winding production steps

Three TF construction sites at ASG (EU, Italy), Mitsubishi (JA) and Toshiba (JA)

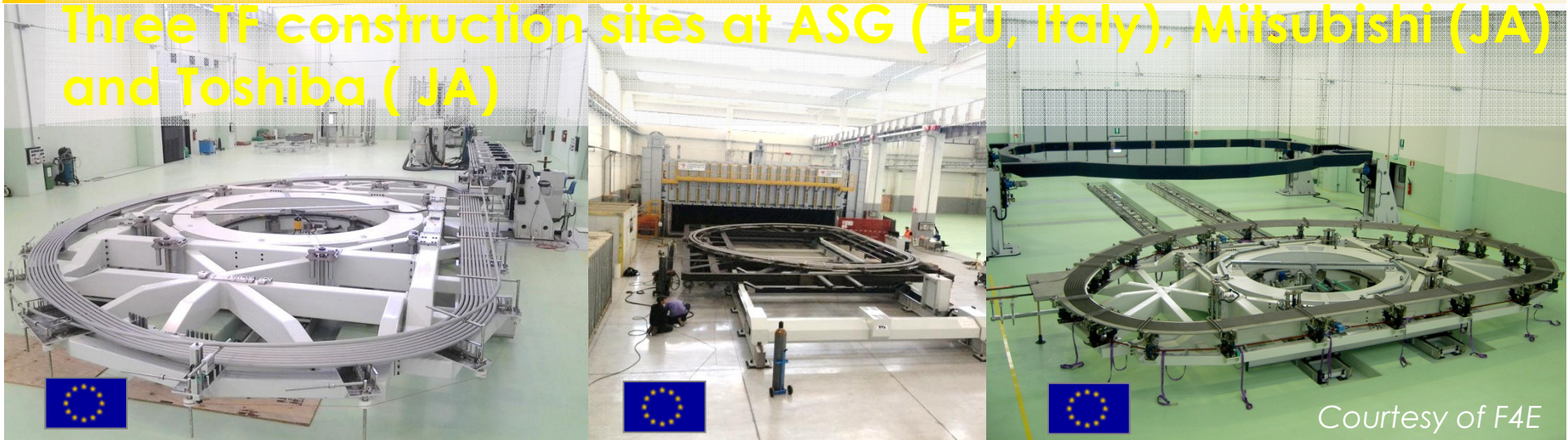

Winding machine lines

Nb₃Sn heat treatment furnaces

Conductor transfer into the radial plates

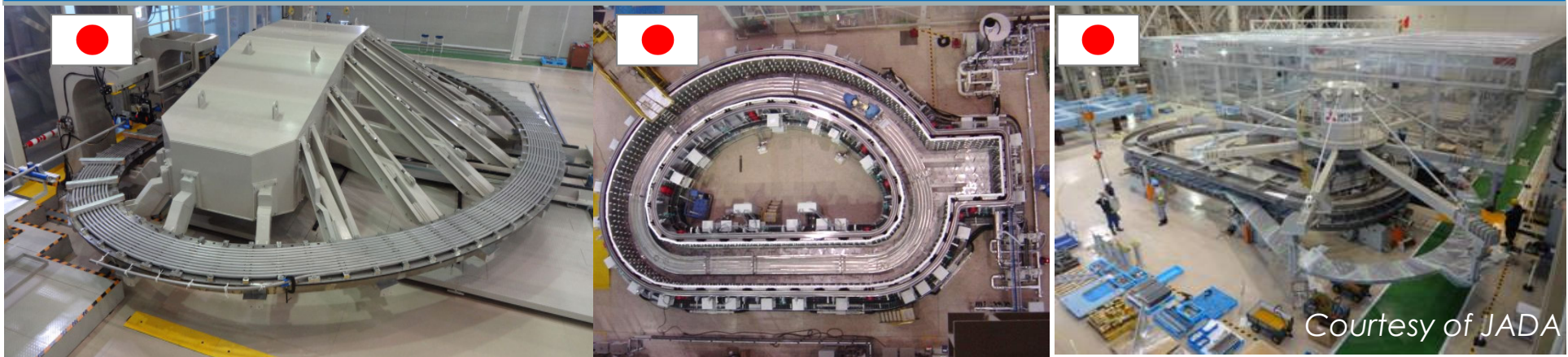



Challenges of winding Heat treatment

- **Wind & React technology** of individual double pancakes (760 m) require large furnaces (fig 1, 2) for **curing of Nb₃Sn @ 650+/- 5 degC for 200 hours step**
- Tight dimensional control of windings manufactured and heat treated to manage final shape before insertion (total length control better than 600 ppm).

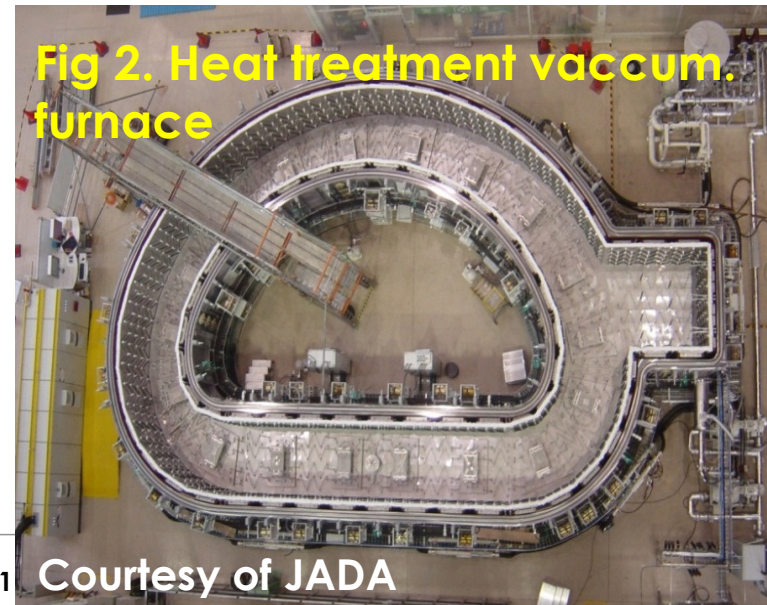



Turn insulation and insertion tool

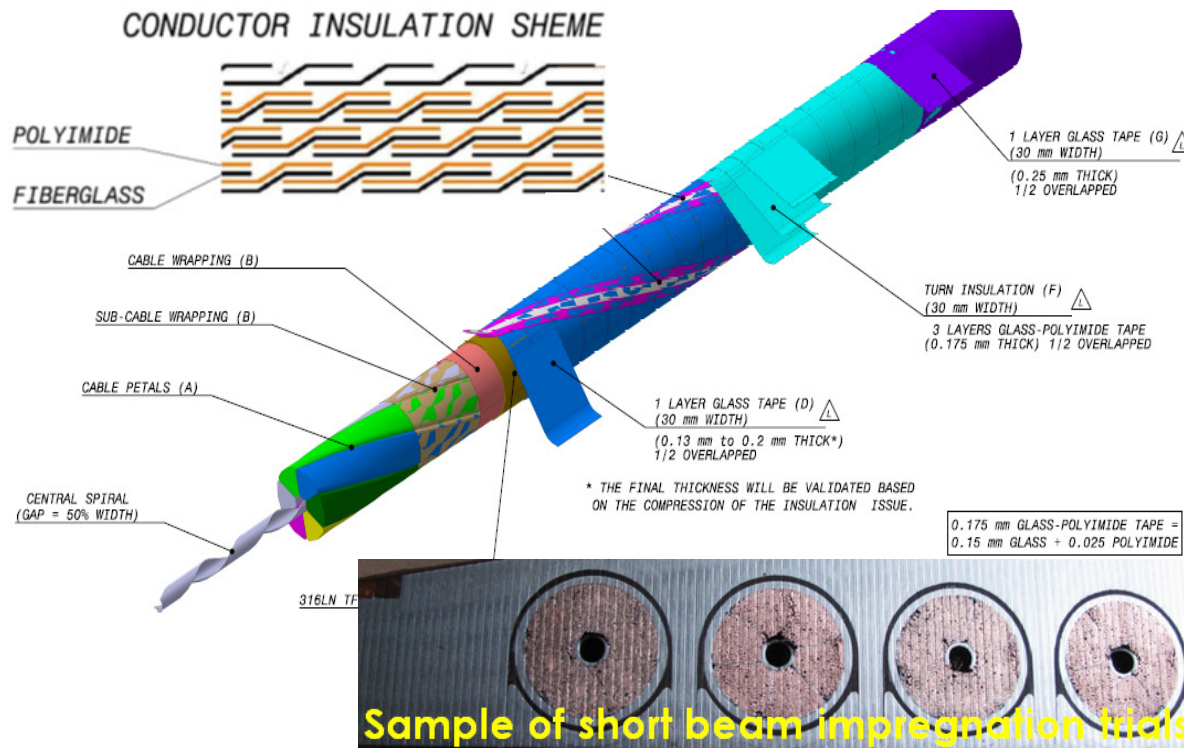

- Highly engineered automated turn insulation machine using **composite Polyimide / S-glass half interleaved insulation tapes** (1.85 mm thick, 2.2 KVDC rated insulation design)
- Additional Stainless steel co-wound tapes** for sensitive quench detection



Arnaud Foussat

Enschede, The Netherlands

Accurate Radial plates sectors assembly

- Development of state of art welding technologies to join the radial plate forgings sub-sections (narrow gap TIG welding, electron beam welding or laser welding) over 120 mm thickness per ISO5817 quality lev B .
- After winding heat treatment, double pancake geometry is measured by laser scan (10 micrometers/m) then RP final machined over 14 m with portal machine (0,1 mm accuracy).

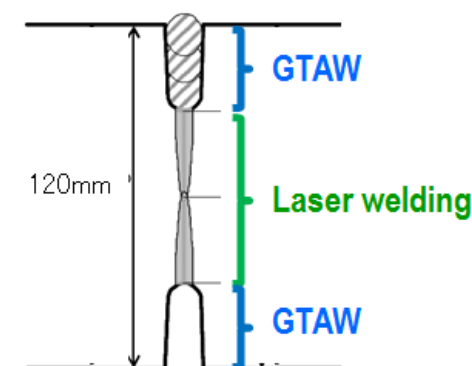
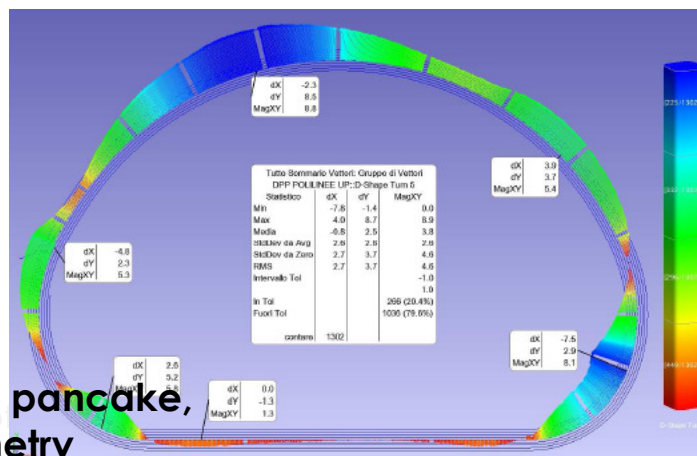
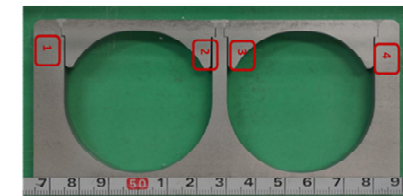

Fig 1. a) Laser scanning of double pancake, b) Resultant winding survey geometry

Fig 4. n-GTAW + Laser joint (24kW) weldment

High technology Laser closure welding

- More than 1.5 kms of 2 mm deep weld lines to enclose CIC conductor into radial plates by 2 kW fiber Laser welding with optical guidance along 0.2 mm gap



a) Cross section of covers fitted on grooves



b) Typical closure cover laser welding bead

Fig.1 Laser welding of the cover plates with 3 welding robots



Large Coils cases manufacture challenge

- Mass production of 4500 tons of large high strength 316LN steel structure
- NG-TIG welded assembly of forged plates up to 200 mm thick and tight deformation control of ~ 3 mm to satisfy final shape.

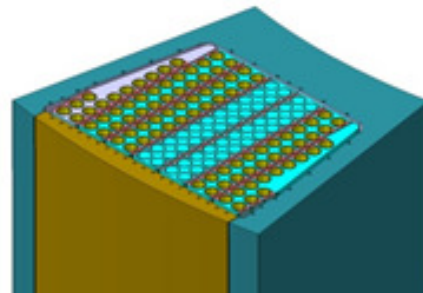

Fig. 1 Cut view of final encased winding

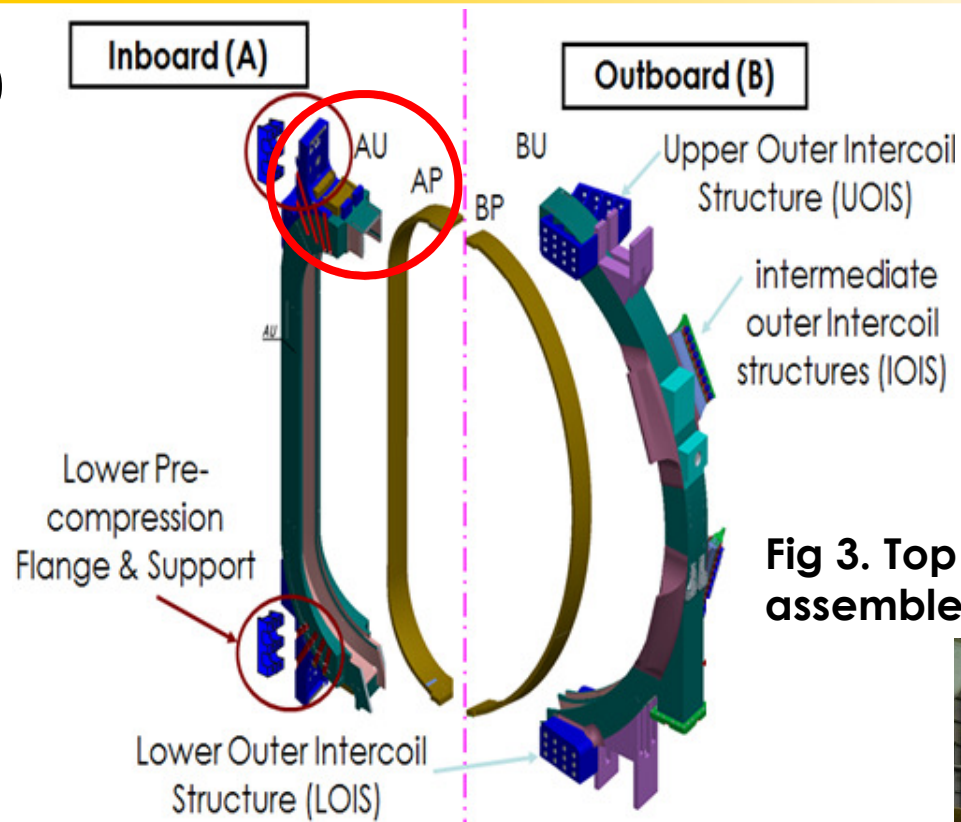
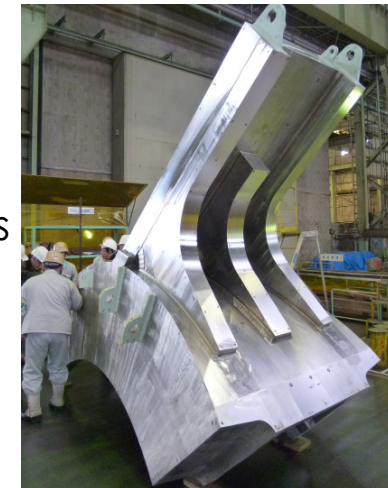

Fig 3. Top inboard assembled segment

Fig. 2 TFC sub assemblies parts,

15m, 210 tons





Wide range challenges on coil integration

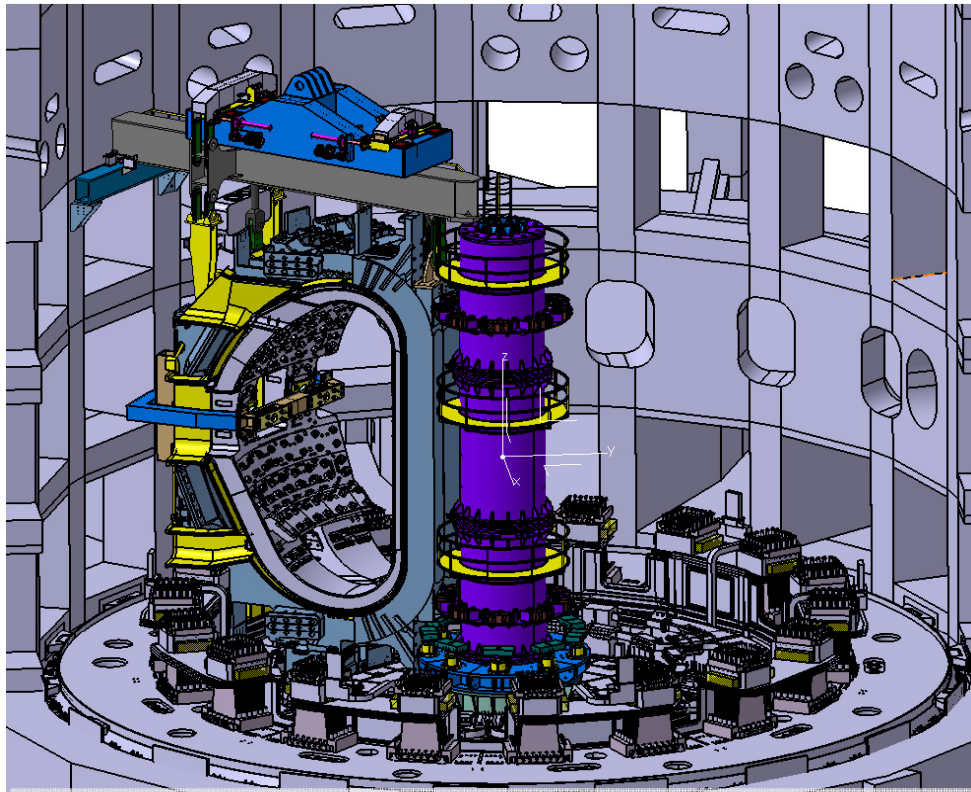

Fig 1- TF sector in-pit Assembly tool

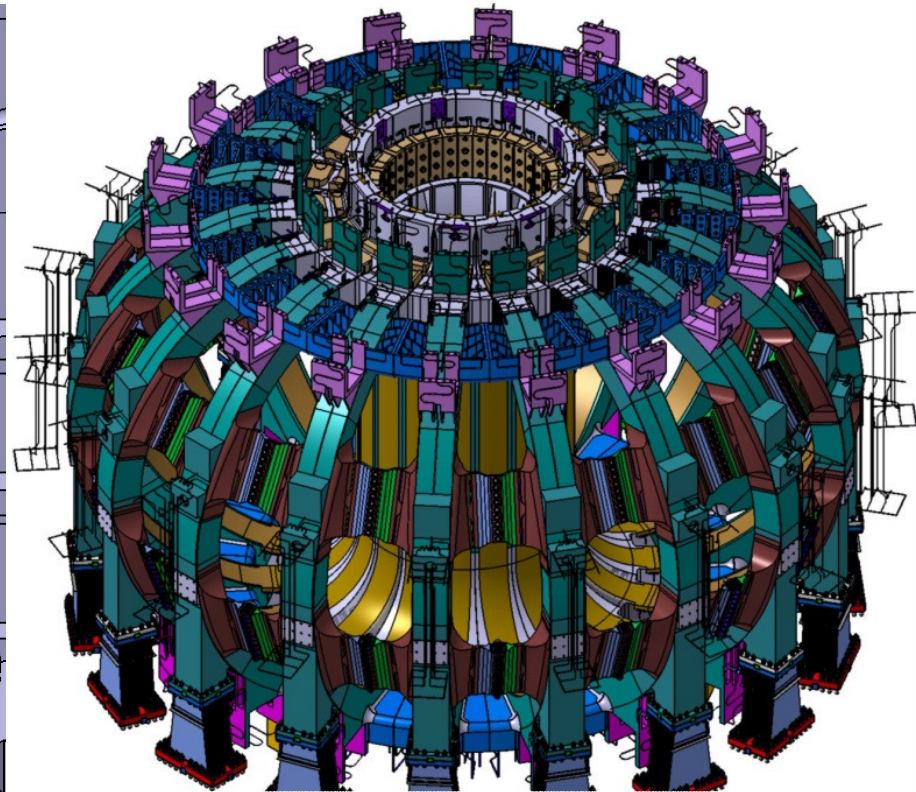

Fig 2- View of TF assembly

- From 2017 onwards, assembly of 9 TF coils pairs equipped with vacuum vessel using dedicated jigs, each of 980 tons with tight assembly tolerances requirements (< 2 mm) and use of customized shimming capability within $1/10^{\text{th}}$ mil accuracy.



- ITER Tokamak Project and site
- Magnet System
- Toroidal Field coils design
- Engineering manufacture challenges

Material development

- Summary

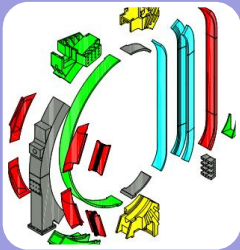

TF case high strength material features

Structural cryogenic material

The SS316LN structural materials withstand large magnetic forces at 4K requiring both high strength (from 900 MPa YS) and good fracture toughness ($>180 \text{ Mpa}\cdot\text{m}^{0.5}$), consolidated by extensive QC mechanical tests campaign at 4K (tensile, FCGR, S-N curves (see back up slide).

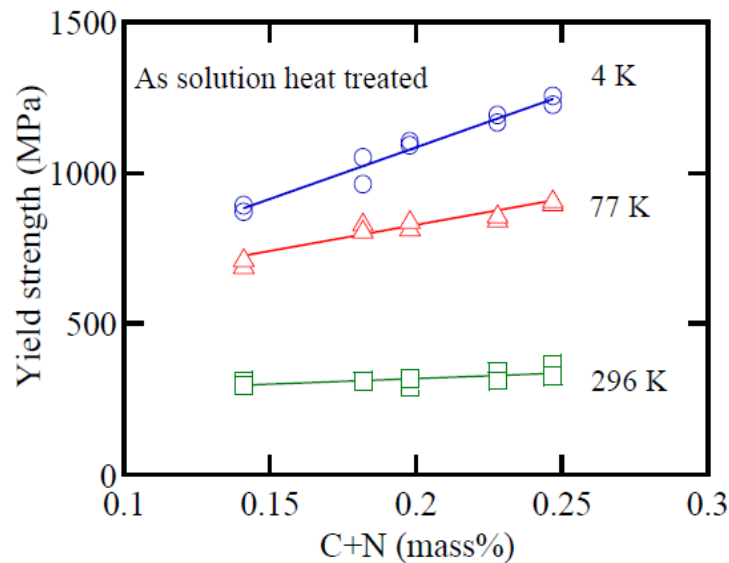

Fig1. Relationship between strength at 4K and C+N content – JSME construction code (JADA)

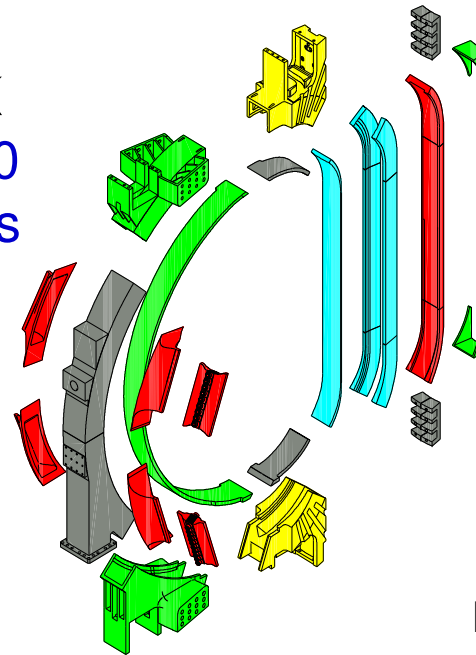

Fig 2. properties class of TFC structure material

Class	Yield Strength at 4K	Color
C1	> 1000 MPa	Red
C2	> 900 MPa	Blue
C3	> 700 MPa	Grey
C3A	And @ RT > 260 MPa	Yellow
C4	> 500 MPa	Green

Ref [8]



Fig 3 Multi axis forging on ingots after melted electric arc furnace refinement process.

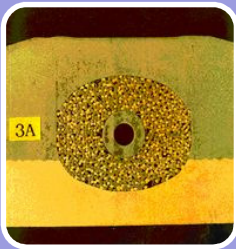

TF coil electrical joint manufacture challenges



Electrical joints design

- **Twin box electrical joints based on bimetallic Oxygen Free High Conductivity Copper C10100 series sole (RRR: 200-300) explosion bonded to Stainless steel 316L(N).**
- **Specified joint resistance $R_j < 2 \text{ n}\Omega$**
- **Joints operate at DC with low losses ($< 10 \text{ W peak}$) and are cooled in series with the winding exits conductors.**

Fig. 1 Terminal joint region on winding double pancake

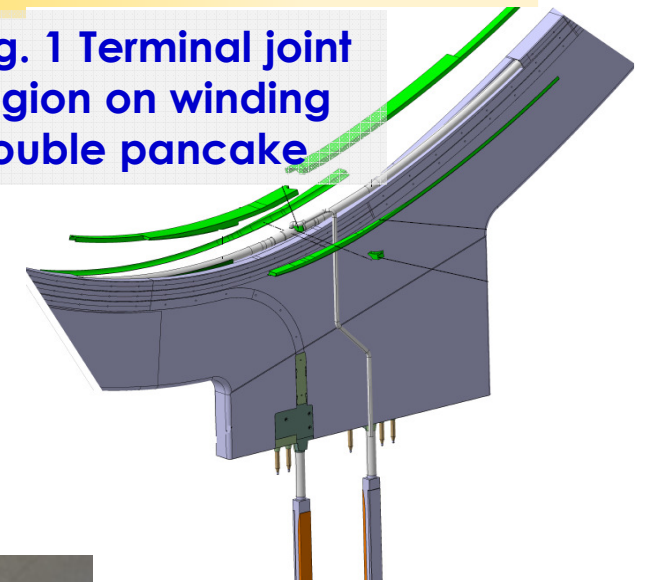
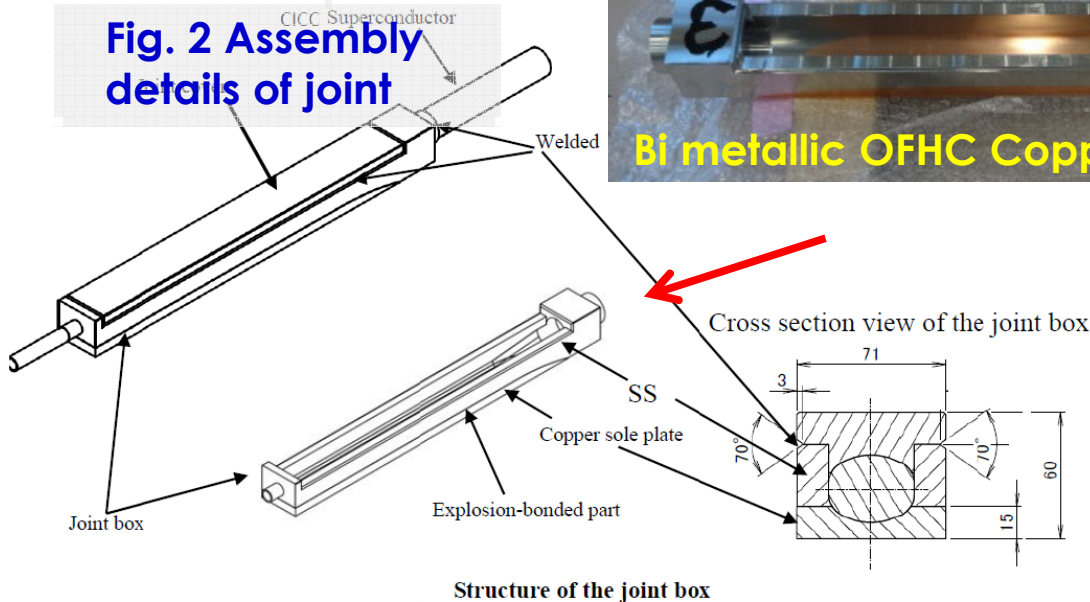

Fig. 2 Assembly details of joint



Bi metallic OFHC Copper/SS twin box

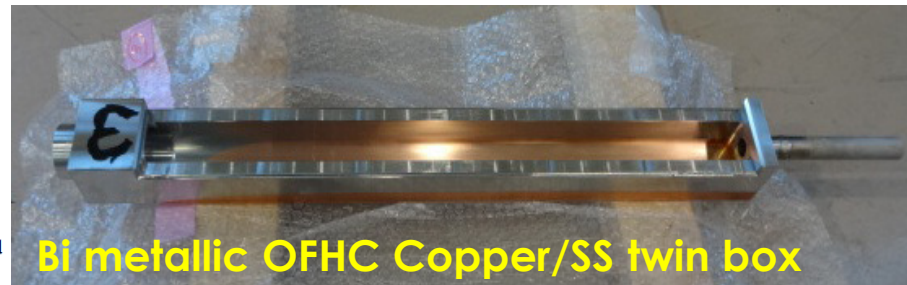
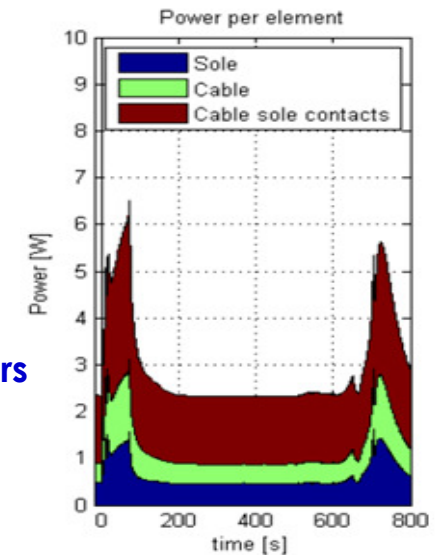
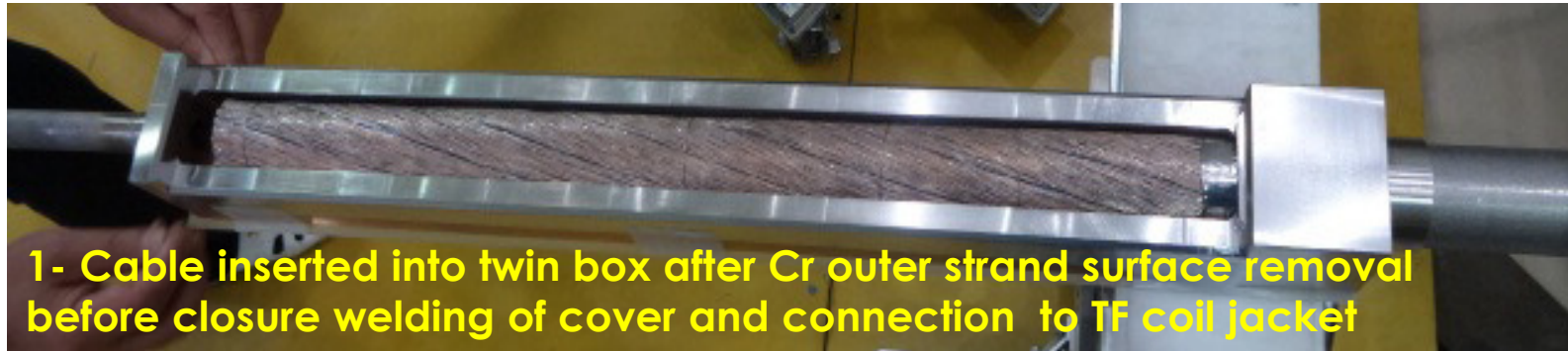

Fig.3 Joint losses simulated contributors with Jack-Pot code (Twente Univ. Tec. report, G Rolando, A Nijhuis)



TF Joint manufacture steps



1- Cable inserted into twin box after Cr outer strand surface removal before closure welding of cover and connection to TF coil jacket

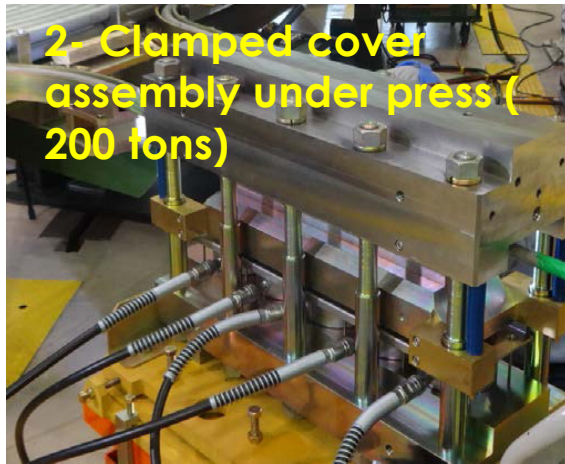

2- Clamped cover assembly under press (200 tons)

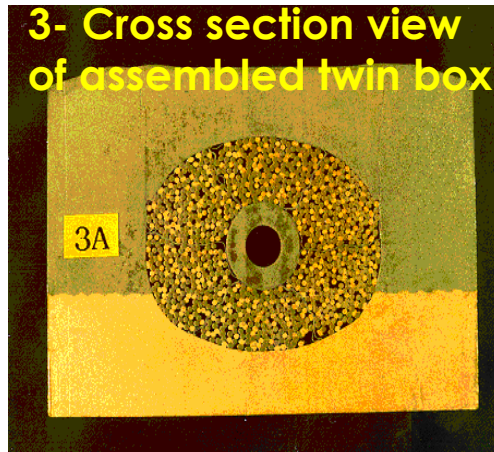

3- Cross section view of assembled twin box

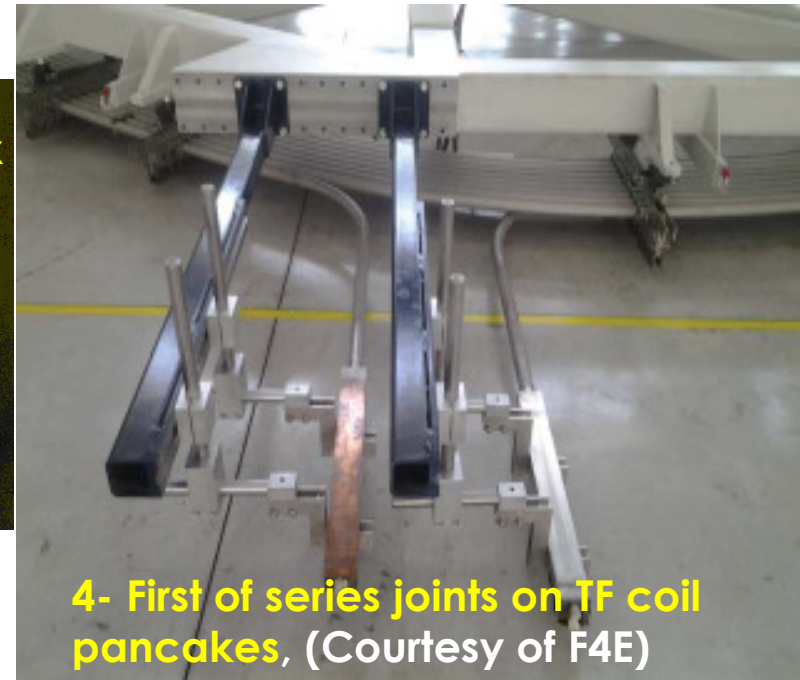

4- First of series joints on TF coil pancakes, (Courtesy of F4E)



Bi-metallic joints material benchmarking

- **Extensive quality check on bi-metallic material** in collaboration with CERN on various supply lines to constitute a database, especially on **RRR values increase after heat treatment.**

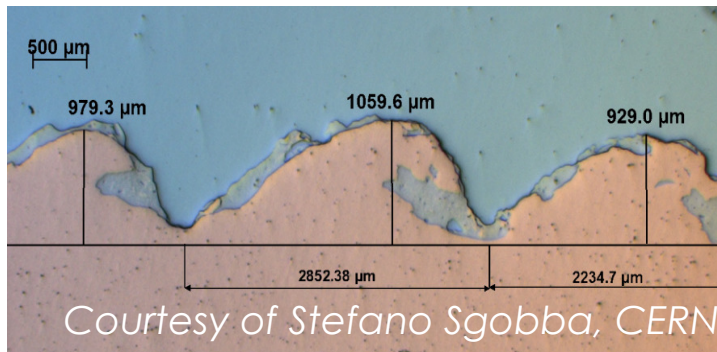

Fig 1. Micrograph of explosion welding interface with shear wave effect.

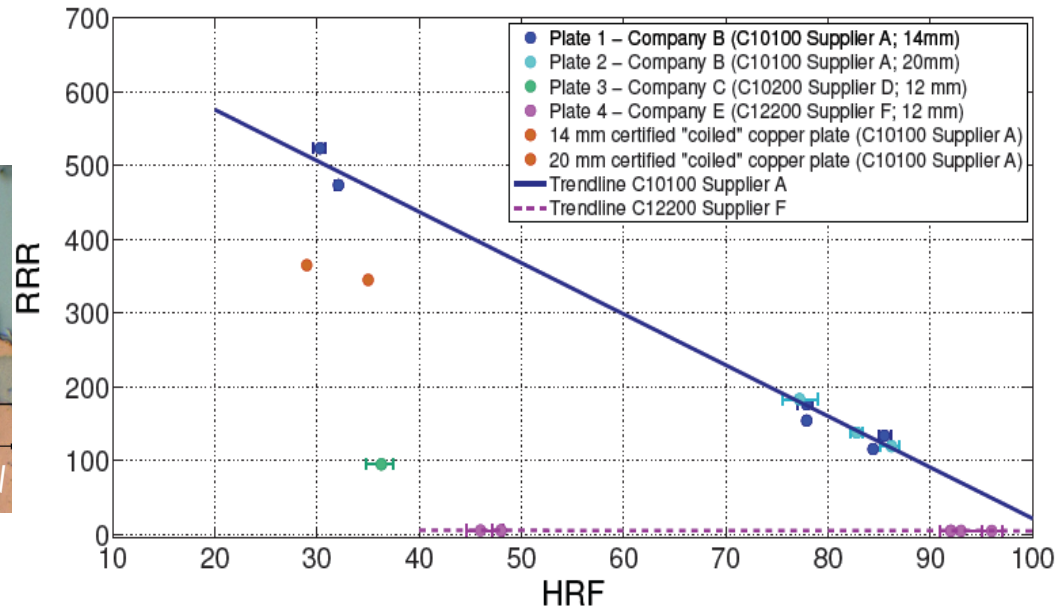

Fig 2. RRR values vs. Hardness HRF measurement on OHFC coppers used from joints bi-metallic suppliers. Presented at ICMC Oral ID 404-6 by S. Langeslag 'Extensive characterisation of Copper-clad plates, Bonded by the Explosive Technique, for ITER Electrical Joints'



TF coil helium inlet manufacture challenges



Helium Inlets manufacture challenges

- One helium inlet supply (16 g/s, 4.5 K @ 0.55 Mpa) per double pancake length of 720 m (see Fig .1).
- Limited pressure drop required (measured 660 Pa vs 160 Pa/m of CICC)
- Fatigue strength requirement of heat treated penetrating fillet weld under 30000 lifetime cycles.

Fig 1. Overall view of 7 winding inlets layout

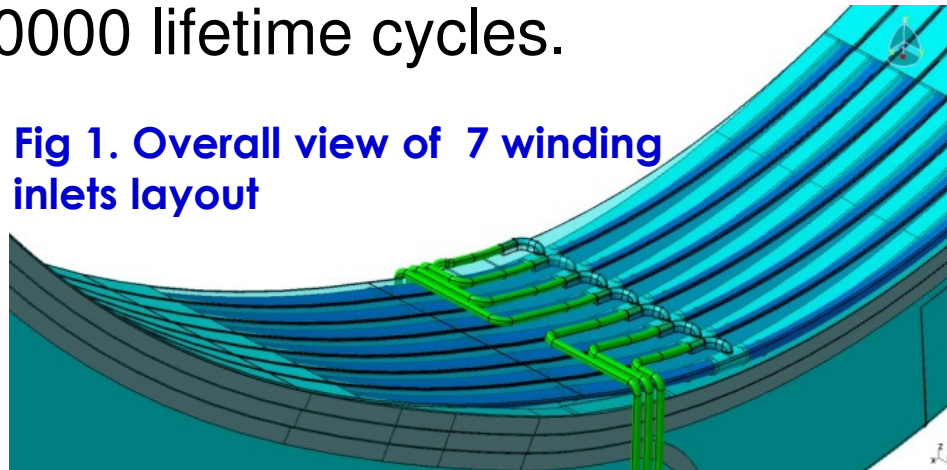

Fig 2. Fabrication of Helium inlet onto conductor

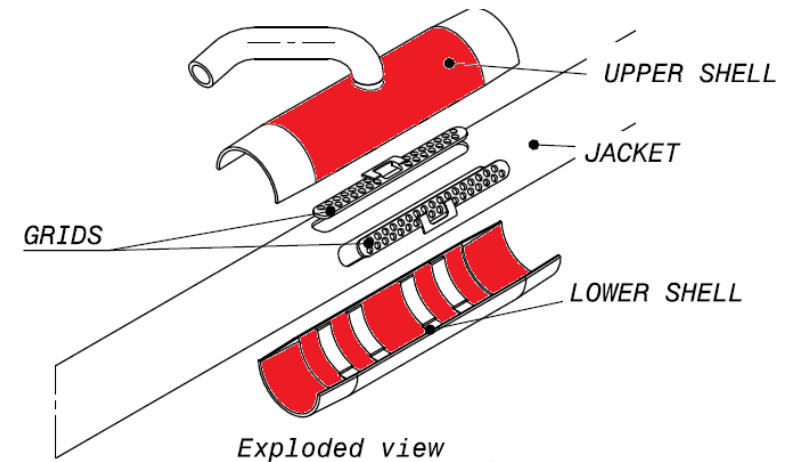

Fig 3. Exploded view of TF Helium inlet)



Crucial selection of inlet weld material

- ER317LN (DIN 1.4453) austenitic filler metal with low C (0.021 %Wt) chosen to limit grain boundary sensitization forming chromium-rich intermetallic precipitates ($M_{23}C_6$) (fig. 1)
- Intergranular corrosion also prevented after a heat treatment of 1000 hours at 700 °C
- No δ -ferrite allowed as it changes to a brittle phase at 4 K during reaction heat treatment

Fig 1. example of micrograph of intergranular sensitization in HAZ sample ASTM A262 in (X 500), CERN courtesy

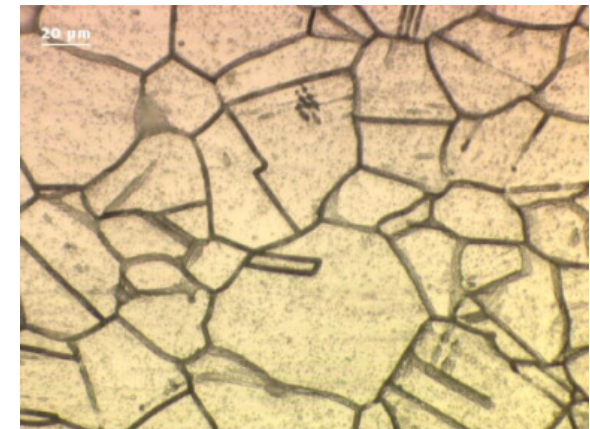

Ref [9]

Cyclic fatigue test of inlet prototypes

- Design by experiment through Statistical fatigue mechanical tests [see reference book on *Fatigue Strength of Welded Structure by Maddox, 1991*]
- Fatigue test at 4K of 6 prototypes at nominal strain $(10.2 \pm 2.3) \times 10^{-4} \epsilon$ over 261.000 cycles representative of a population of 126 inlets.
(design lifetime of 30.000 cycles)
- All 6 samples successfully tested at KIT institute (D), two of them with 15% extra strain margin up to 600.000 cycles.



Fig1. TF inlets fatigue test samples



Ref [10,11]

Fig 2. Fatigue tensile test machine layout (courtesy of KIT)



High Voltage design challenges



High Voltages features in TF coils

- Operating transient voltage up to 18kV to ground in accidental short condition.
- Multiple **high voltage wires feedthroughs** (see fig.1) through 6 mm thick ground insulation is a potential risk at manufacture;
- **Hence 2 stages high quality Vacuum Pressure impregnation of feedthroughs insulations (DP and Winding pack)**, then final wire connection wet insulation (see next slide)
- Extra **electrical tracking length criteria** as a mitigation against de-bonding / cracking of insulation system **during a He leak under atmosphere.** (154 mm @ 19kV, SF = 4)

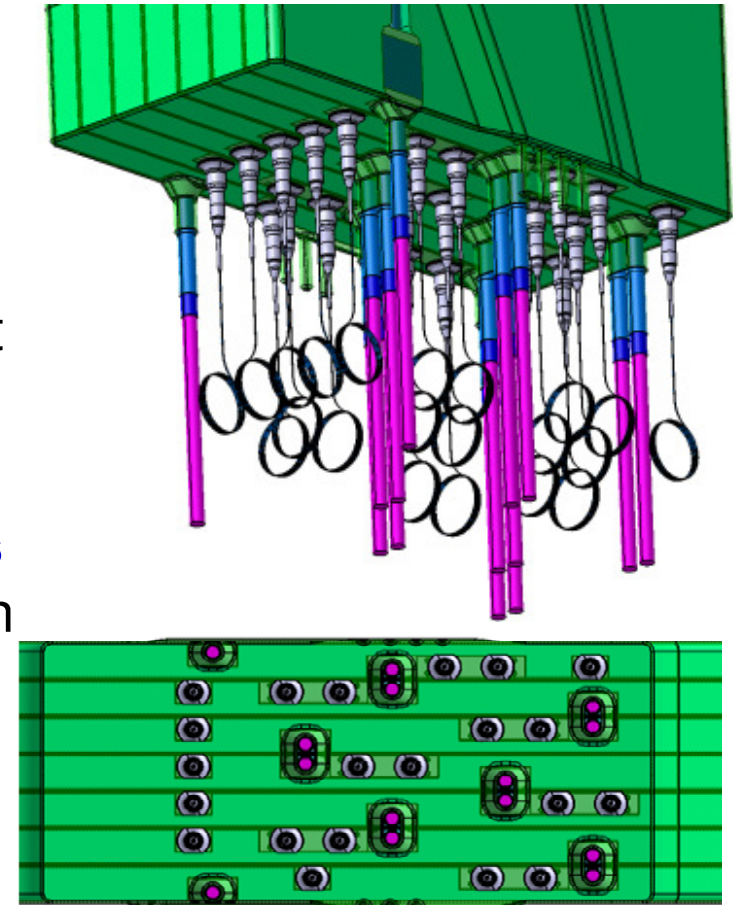

Fig. 1 Layout of exit high voltage feedthroughs in terminal TF winding



TF terminal region, feedthroughs

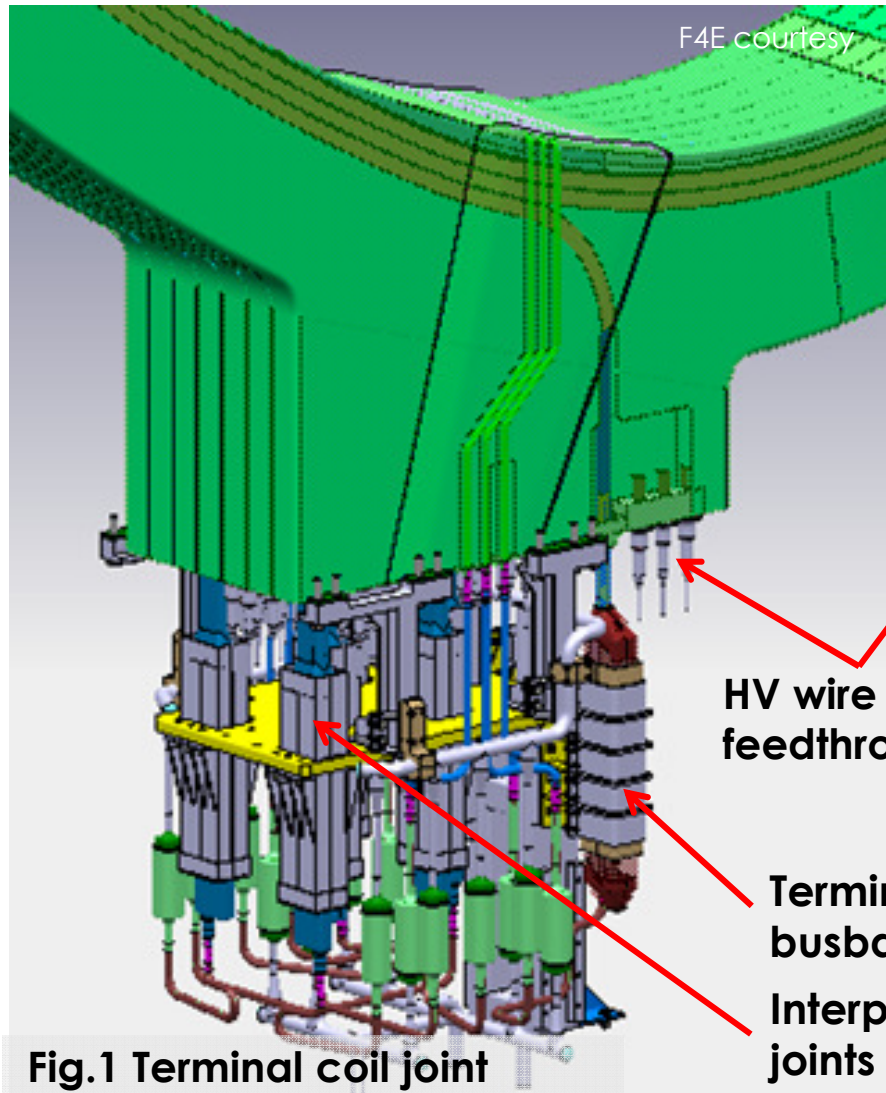

Fig.1 Terminal coil joint region layout

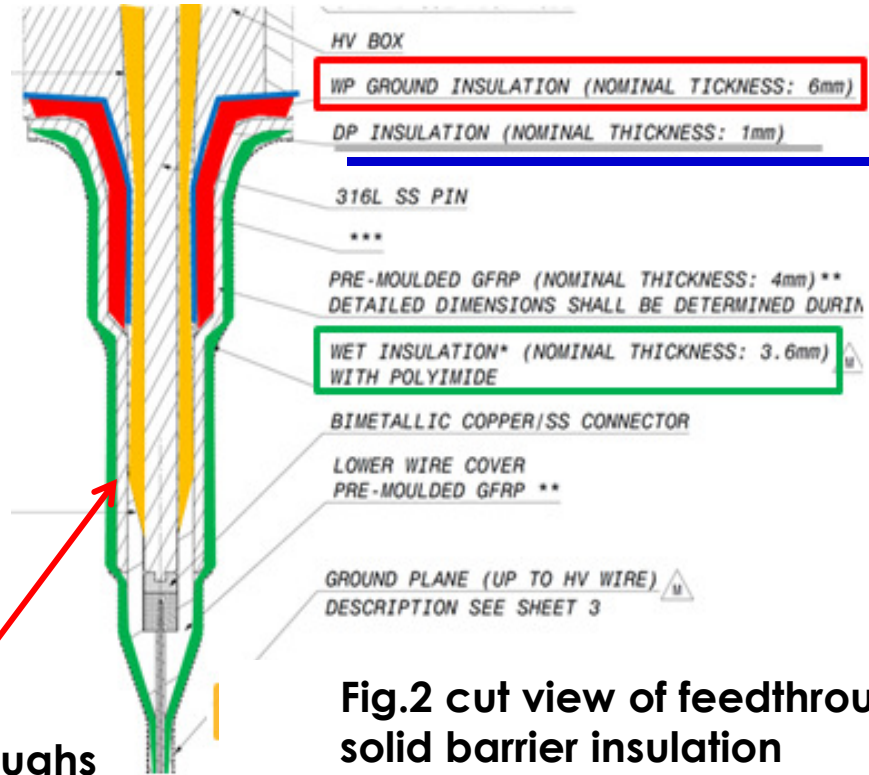

Fig.2 cut view of feedthroughs with solid barrier insulation

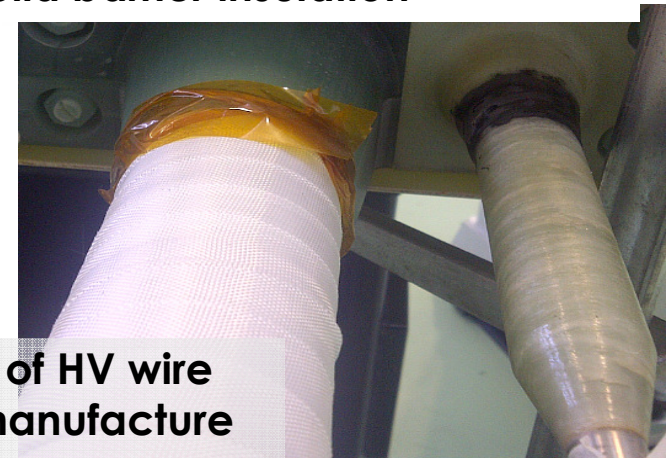
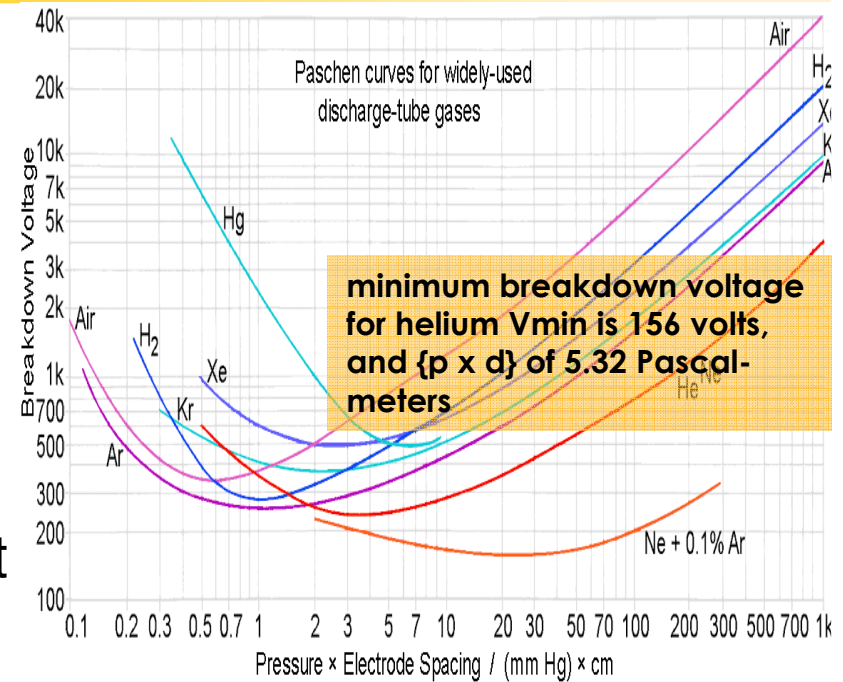

Fig.3 First stage of HV wire feedthroughs manufacture



Stringent acceptance high voltages testing

- In addition to DC and AC repeated manufacture coils tests (see Tab.1), each winding will be Paschen proof tested up to 8KV to ground as a worst case electrical failure combined with loss of vacuum insulation.
- Importance reference of HV Paschen tests performed onto W7-X coils project revealing insulation weaknesses at exits conductors.



Tab 1. Acceptance and Manufacturing Test Voltage Levels

	DC Acceptance Test kV	AC Acceptance Test kV	DC Manufacturing Test kV	AC Manufacturing Test kV	Paschen Manufacturing Test kV
Turn to RP	>2.2	0.4	>2.2	>0.4	2.2
DP to DP	>3.4	0.8	>3.4	>0.8	3.4
WP to ground	>19.0	2.5	>19.0	>2.5	8.0

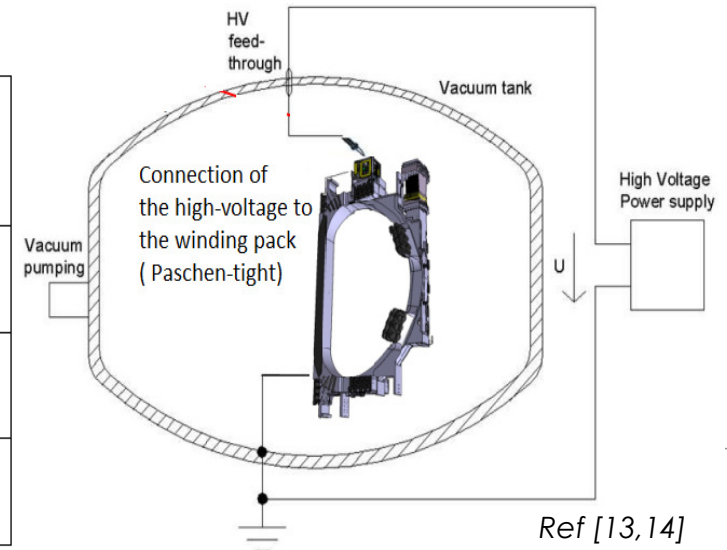



Precompression composite rings



Precompression rings composite material

- Innovative composite material versus traditional aerospace manufacture sizes
- Purpose to preload each TF flange up to 37 MN radial load and to prevent separation gaps of the poloidal keys between coils.
- Benefit is hampered eddy currents and reduction of local fatigue

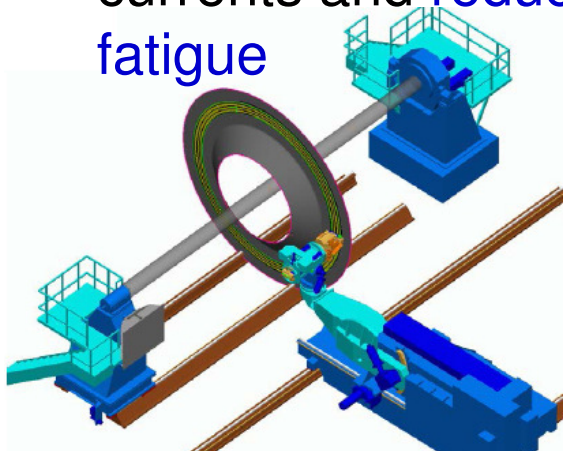

Fig 2. Manufacture from **S2 fibre-Glass unidirectional preimpregnated composite tows steering by** Advanced Fiber Placement (AFP)

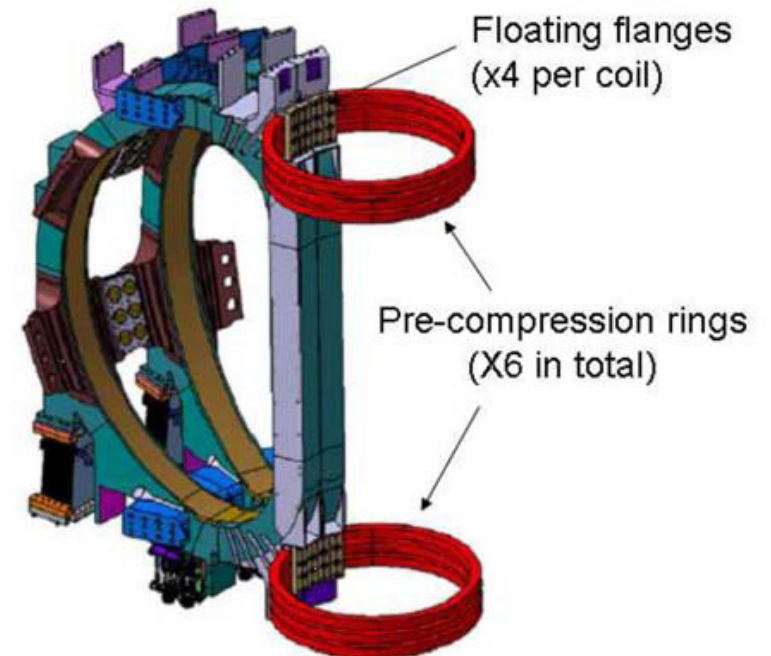

Fig. 1 Ring assembly with **diameter of 5 m and 337 x 288 mm² in cross-section,**

Ref [16,17,18]



Advanced design assessment method

- Operating **430 Mpa hoop stress** with safety factor of 3-4 to rupture
- Use of Tsai-Hill interactive phenomenological structural failure strength criteria to match anisotropic composite material properties at RT & 4K.

$$\left(\frac{\sigma_X}{S_1}\right)^2 + \left(\frac{\sigma_Y}{S_2}\right)^2 + \left(\frac{\tau_{XY}}{S_{12}}\right)^2 + \left(\frac{\tau_{XZ}}{S_{13}}\right)^2 + \left(\frac{\tau_{YZ}}{S_{23}}\right)^2 - \frac{\sigma_X \sigma_Y}{S_1^2} \leq 1$$

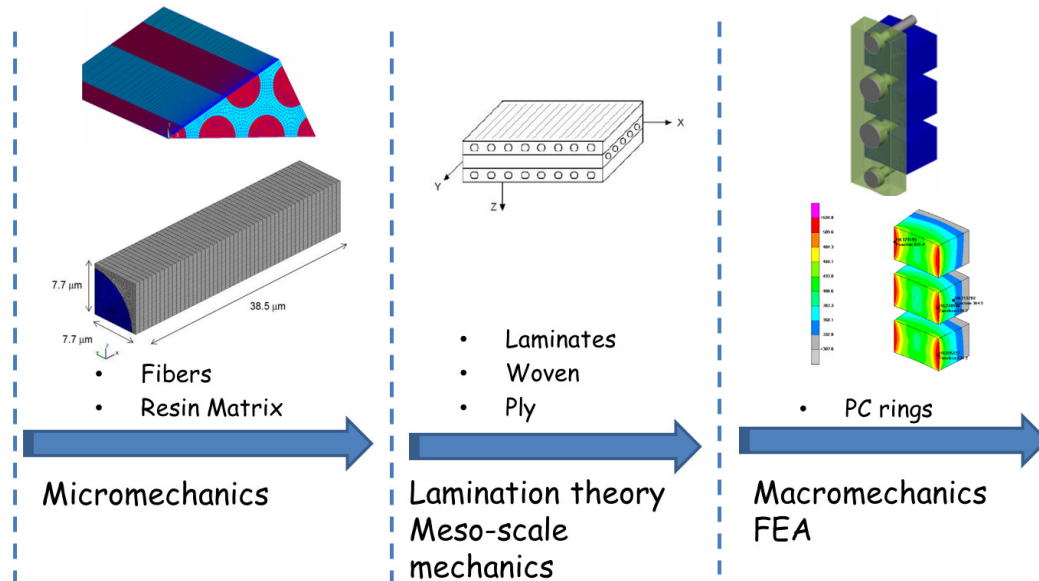
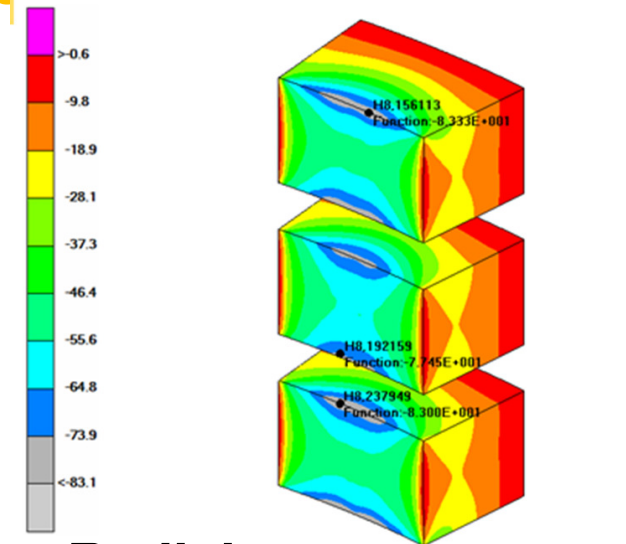
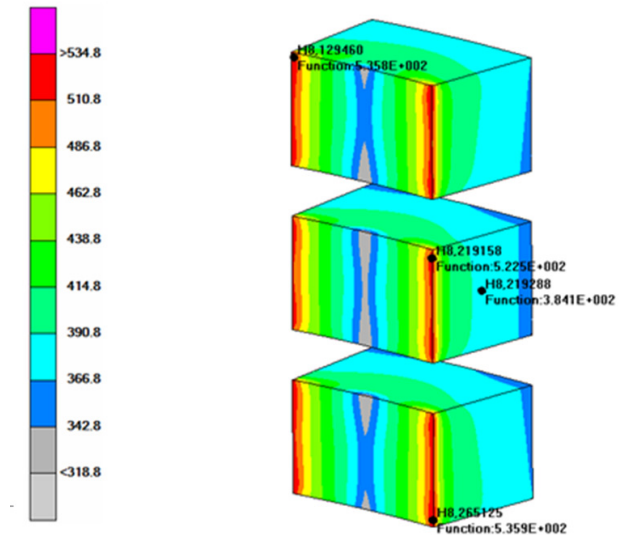

Fig.1 Multi scale models analysis from Micro, Meso to Macroscale properties



Radial stress



Hoop stress

From test campaign to fabrication

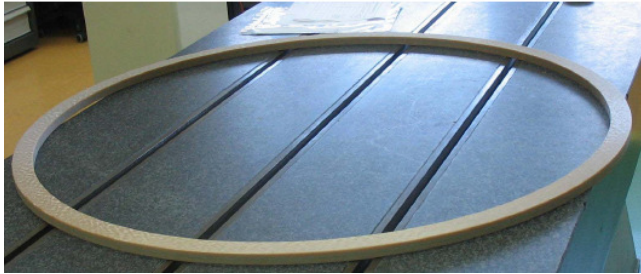

a) 1/5th composite sub scale prototype ring - b) Picture of failed 1/5th ring

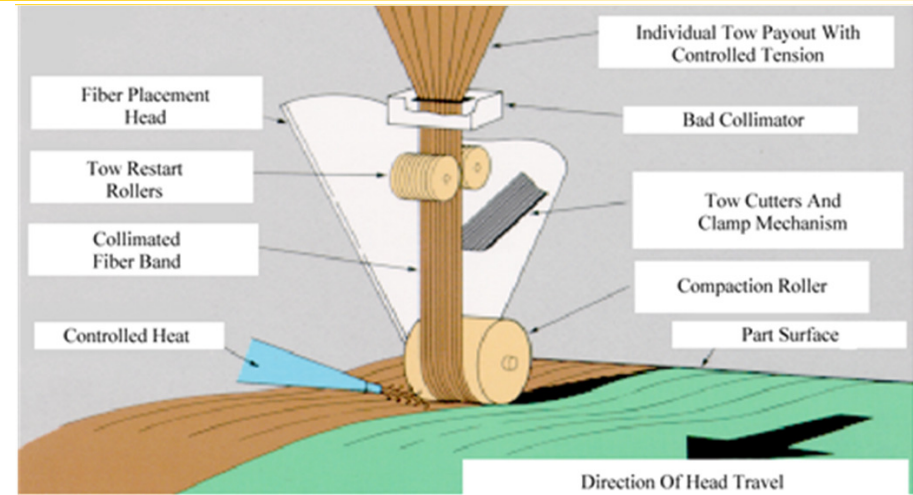

c) Advanced Fiber Placement Technology (AFP) on a flat annular tool (EADS Airbus)



b) Testing jig installed at ENEA (It, Frascati) for mock-up rupture test

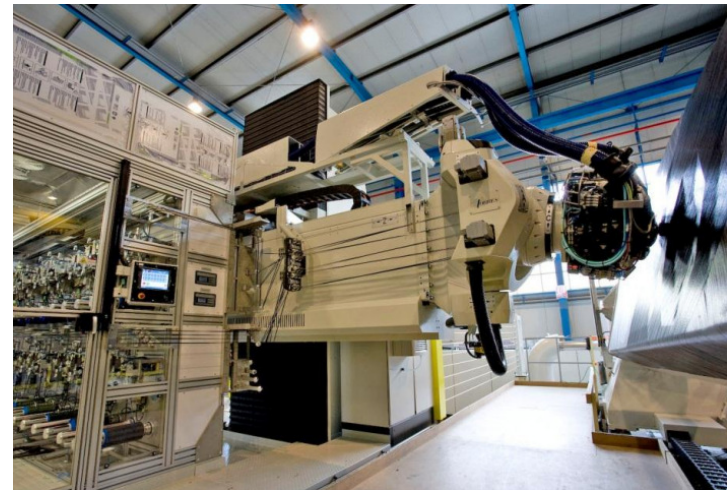

Summary

- ITER TF coils system procurements packages under way since 2008 rely on worldwide collaboration (JA, EU, KO, CN, RF, US)
- Most challenging and innovative superconducting projects in the world today within magnetic confinement fusion power production.
- The qualification of last manufacture steps is on going and the construction phase of first series winding components has started at main workshop facilities in Europe and Japan.
- Coil design success relies on large forefront material developments at cryogenics temperature and challenges on engineering fabrication processes under current coils qualification phase.
- Technical challenges are being overcome but many others are ahead of the coming first of series coils by beg. 2016, from their integration from 2018, till the first plasma commissioning from 2021.
- > €1B equivalent total industrial TF contracts is anticipated amongst all contributors.

References

ITER machine scenario:

[1] C. Sips Advanced scenarios for ITER operation, Advanced scenarios for ITER operation, CPP 2004

[2] Y. Shimomura, R Aymar et al, ITER overview

TF coils:

[3] F Savary, J Knaster, "The Toroidal Field Coils for the ITER Project", IEEE TRANSACTIONS on Applied Superconductivity, Vol. 22, NO. 3, June 2012

[4] L. T. Summers, M. W. Guinan, J. R. Miller, P. A. Hahn, A Model for the Prediction of Nb₃Sn Critical Current as a Function of Field, Temperature, Strain and Radiation Damage, IEEE Trans Mag, vol 27, 2, March 1991

[5] L. Bottura, A Practical Fit for the Critical Surface of NbTi, IEEE Trans App Sup, vol 10, 1, March 2000

[6] P. Bruzzone, Test Results of Secrets, a Stability Experiment about Segregated Copper, in Cable-in-Conduit Conductors, App Sup Conf, Sept 2000, Virginia Beach, USA

[7] Summary of ITER TF Nb₃Sn strand testing under axial strain, spatial periodic bending and contact stress, A Nijhuis, IEEE Applid Superconductivity 2009, vol. 19 (2), n° 3 (1477 p.)

[8] ITER Structural Material Database Article 5. Qualification of Irradiated Insulation Materials (Document No. 4)

[9] 316KN sensitisation: Jesper, H. and Wessling, W., .Neue nichtrostende Stähle für den chemischen Apparatebau,. *Werkstoffe and Korrosion*, Juni 1965, Heft 6, pp. 453-465.

[10] C. Boyer, K. Seo, K. Hamada, A. Foussat, M. Le Rest, N. Mitchell, P. Decool, F. Savary, S. Sgobba, and K-P. Weiss, Validation of Helium Inlet Design for ITER Toroidal Field Coil, to be published in the proceedings of MT23 conference Boston USA 2013 (IEEE Trans. Applied Supercond.)

[11] K.-P. Weiss, Mechanical Fatigue Testing of a TF-He-Inlet Prototype at Cryogenic Temperature IEEE TRANSACTIONS ON APPLIED SUPERCONDUCTIVITY, VOL. 24, NO. 3, JUNE 2014

[12] C Boyer, Validation of Helium Inlet Design for ITER Toroidal Field Coil, IEEE TRANSACTIONS ON APPLIED SUPERCONDUCTIVITY, VOL. 24, NO. 3, JUNE 2013

[13] Knaster J., Paschen tests in superconducting coils: why and how, [Applied Superconductivity, IEEE Transactions on](#) (Volume:22, [Issue: 3](#))

[14] Magnet Superconducting and Electrical Design Criteria (ITER_D_22GRQH v1.2)

[15] T. Taylor et al., "Design of the HTS Current Leads for ITER", *IEEE Trans. Appl. Supercond. Vol. 22 (2012) 4800304–4800304*

ICEC 25 – ICMC 2014 conference, July 7-11

Arnaud Foussat

Enschede, The Netherlands

References

Precompression rings

- [16] A Foussat, Multi-Scale Analysis and Characterisation of ITER Pre-Compression rings, ICMC 2013, Anchorage, Alaska, June 2013
- [17] H. Rajainmaki, The ITER Pre-Compression Rings : A First in Cryogenic Composite Technology, ICMC 2013, June 17-31st, Anchorage
- [18] ASTM D 6671-01. Standard test method for mixed mode I–mode II interlaminar fracture toughness of unidirectional fiber reinforced polymer matrix composites. Annual book of ASTM standards, vol. 15.03; 2001.
- Joints:

Engineering reference books:

- [19] MHD and Fusion Magnets , Thome, Tarrh Ed. Wiley
- [20] **Fatigue Strength of Welded Structure**, [S. J. Maddox](#) Woodhead Publishing, 1 janv. 1991
- [21] Tokamaks, Wesson, 3rd Edition, Oxford Science publication

***Superconducting Magnets :
Demonstrating
hydrogen fusion will
bring a star to Earth . . .***

Thank you

. . . and a path to clean, safe, abundant energy.

Email contact : Arnaud.Foussat@iter.org

BACK UP SLIDES

Fatigue experimental design data

Large amount of experimental fatigue data on 316LN series at 4K to benchmark especially for the fatigue and LEFM models benchmarking.

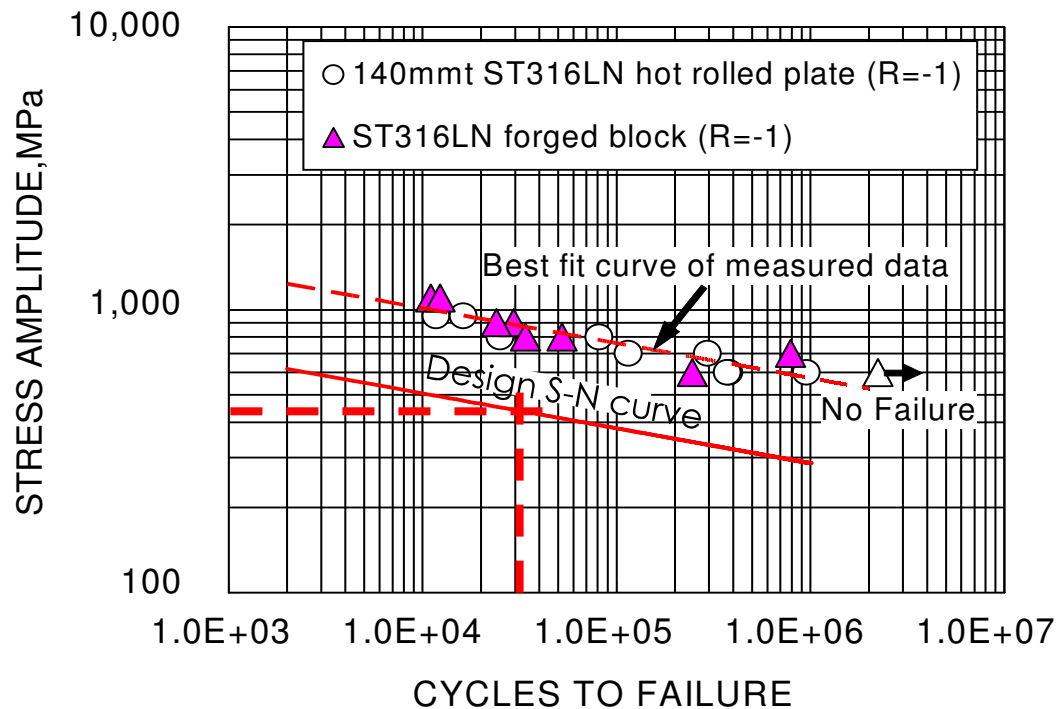

Fig.1 S-N design fatigue curve at 4K of 316LN forged material

Fig. 2 Crack growth rate measurement vs cycle number at 4K of 31LN

Crack propagation rate of transition i :

$$\left(\frac{da}{dN}\right)_i = \begin{cases} 0 & \text{for } \Delta K_i < \Delta K_{th}(R_i) \\ C(\Delta K_i)^m & \text{for } \Delta K_{th}(R_i) < \Delta K_i \end{cases}$$

depending on stress ratio R_i

