

[Invited] Progress on a 100-kW superconducting propulsion unit for zero emission aviation

Min Zhang, Weijia Yuan, Alexander Shchukin, Ercan Ertekin, Yudi Xiao, Muhammad Bin Younas, Roshan Parajuli

Applied Superconductivity Laboratory, University of Strathclyde, Glasgow

Ludovic Ybanez, Alexander Colle

Airbus Upnext

This work covers the update from:

- “ZEST1 Zero Emissions for Sustainable Transport 1”, funded by Innovate UK
- “Superconducting Machines for Zero Emission Aviation”, selected by ERC and funded by UK Research and Innovation

Content

- Introduction
- Fully HTS motor design updates:
 - Cooling system
 - HTS stator design
 - HTS brushless rotor design
 - Rotational motor tests up to 1500 rpm
- Cryogenic inverter design updates

WHY

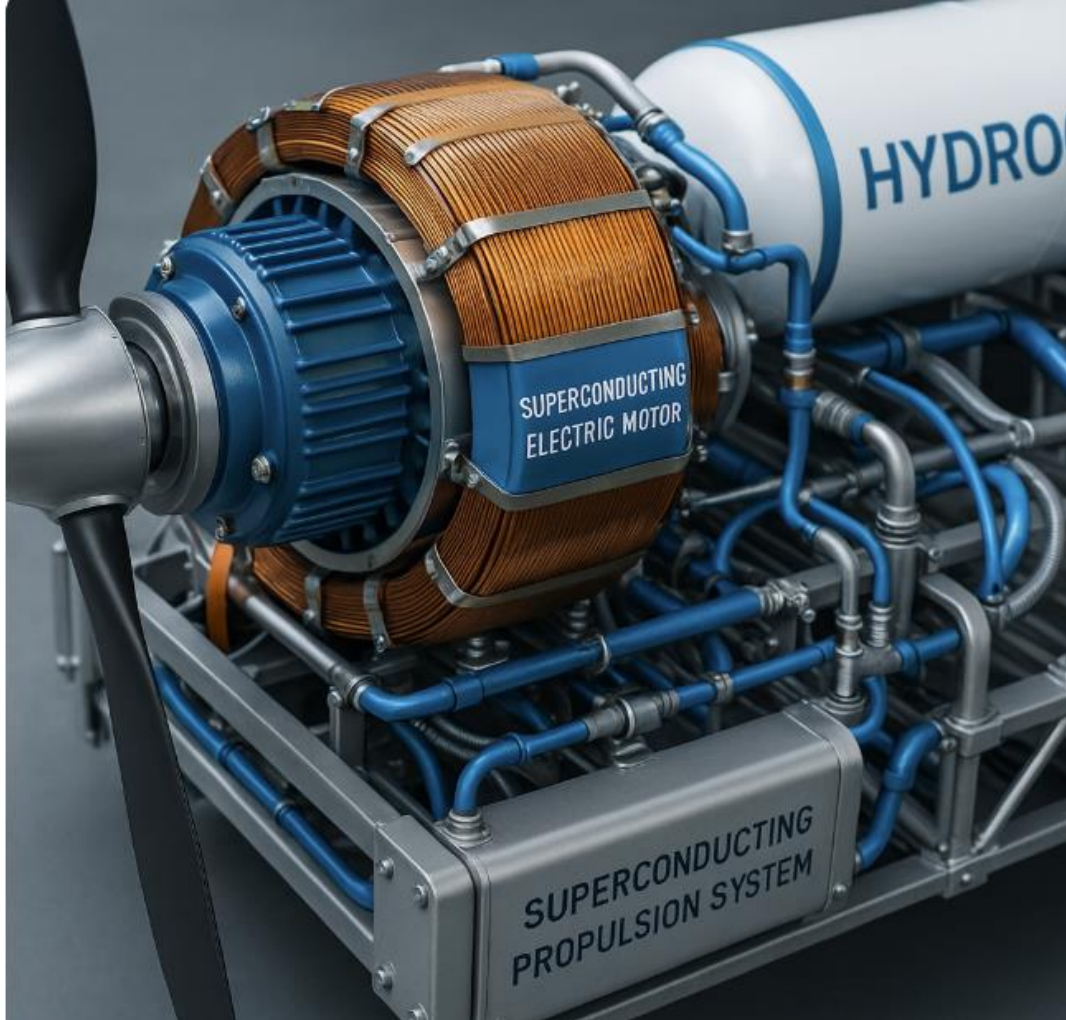

- Emission
- Electrification
- Limitation on existing machines

Chatgpt: a superconducting propulsion system for hydrogen aircraft

WHY

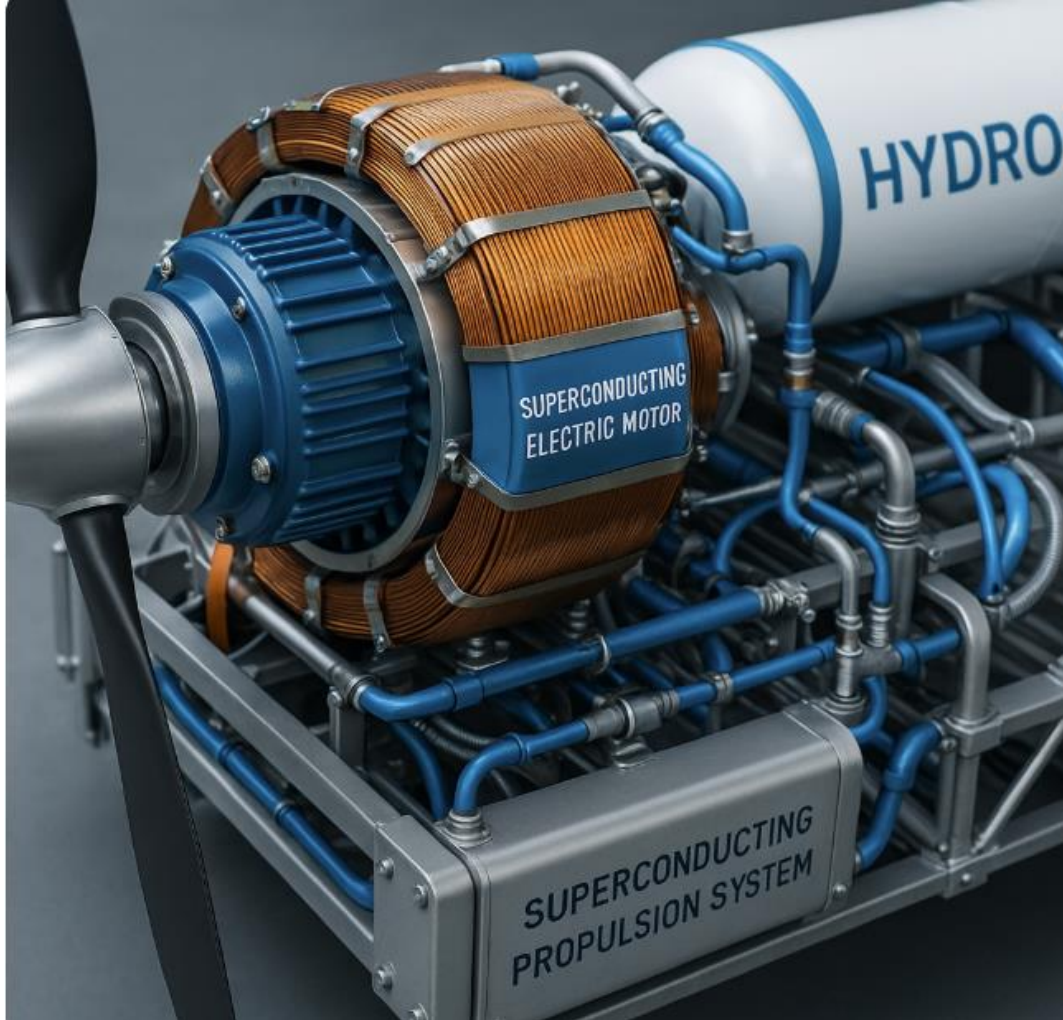

- X Too expensive
- X Technology not mature
- X Reliability issue
- X No supply chain
- X No regulation
- X No certification

Chatgpt: a superconducting propulsion system for hydrogen aircraft

WHY NOT

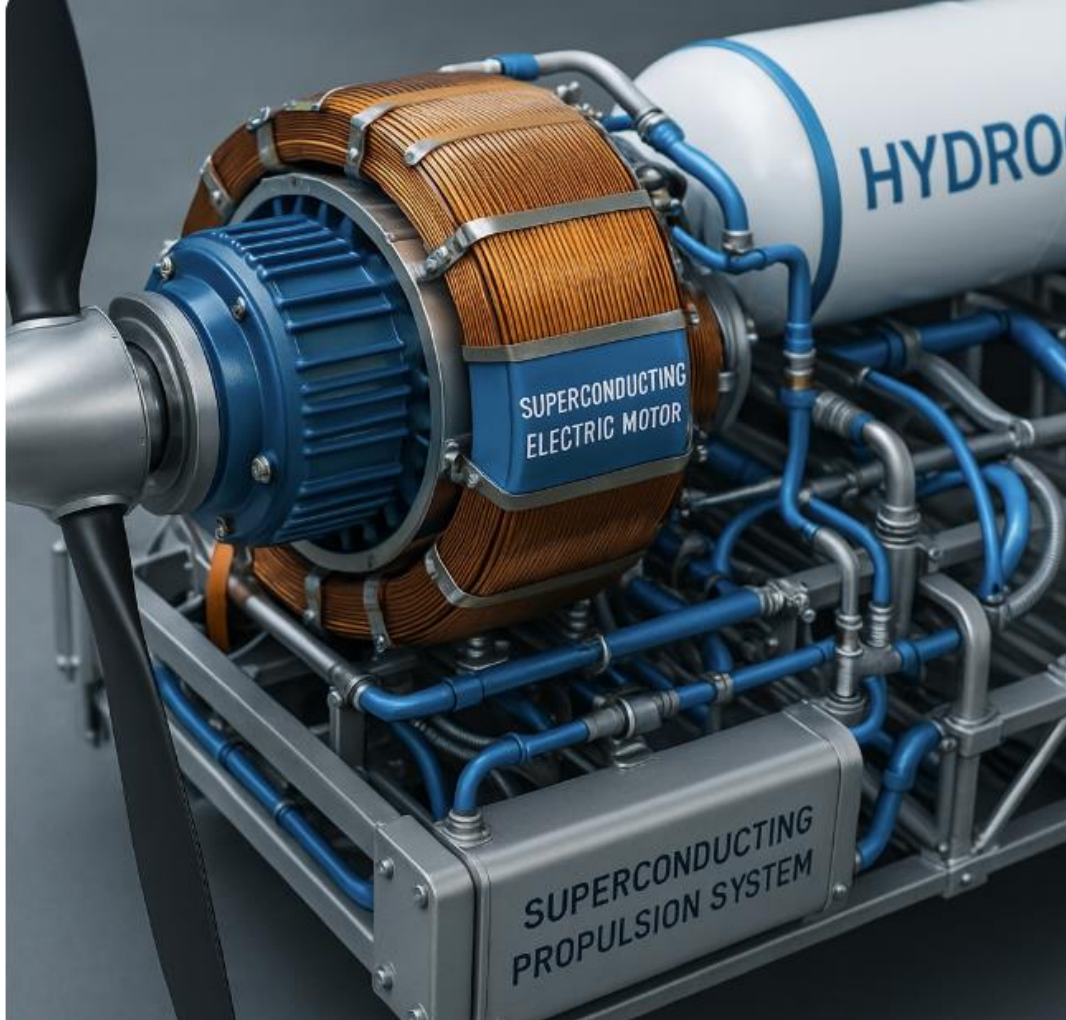

- X Too expensive
- X Technology not mature
- X Reliability issue
- X No supply chain
- X No regulation
- X No certification

Without technology demonstrations, we will never get to address these questions/concerns

Chatgpt: a superconducting propulsion system for hydrogen aircraft

WHY NOT

2017-2020: 15 kW partially HTS motor

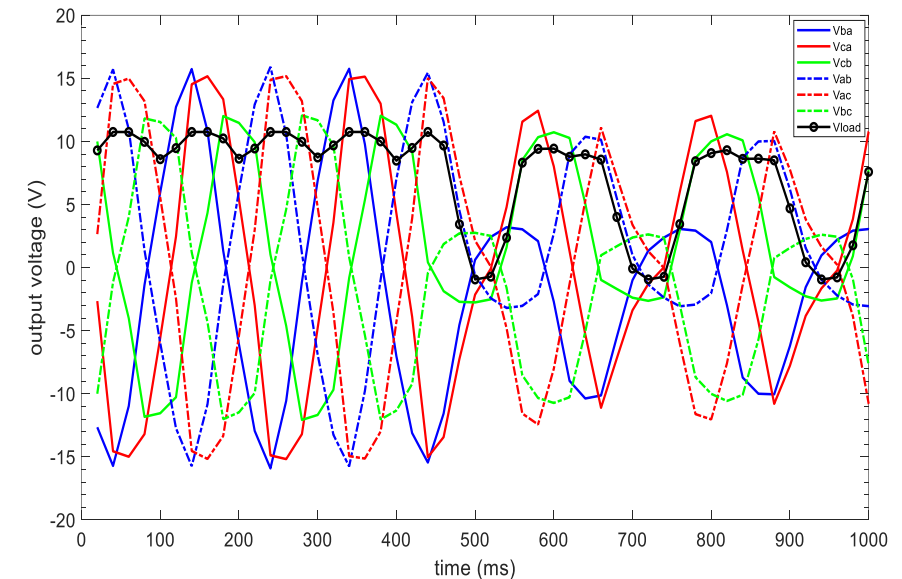
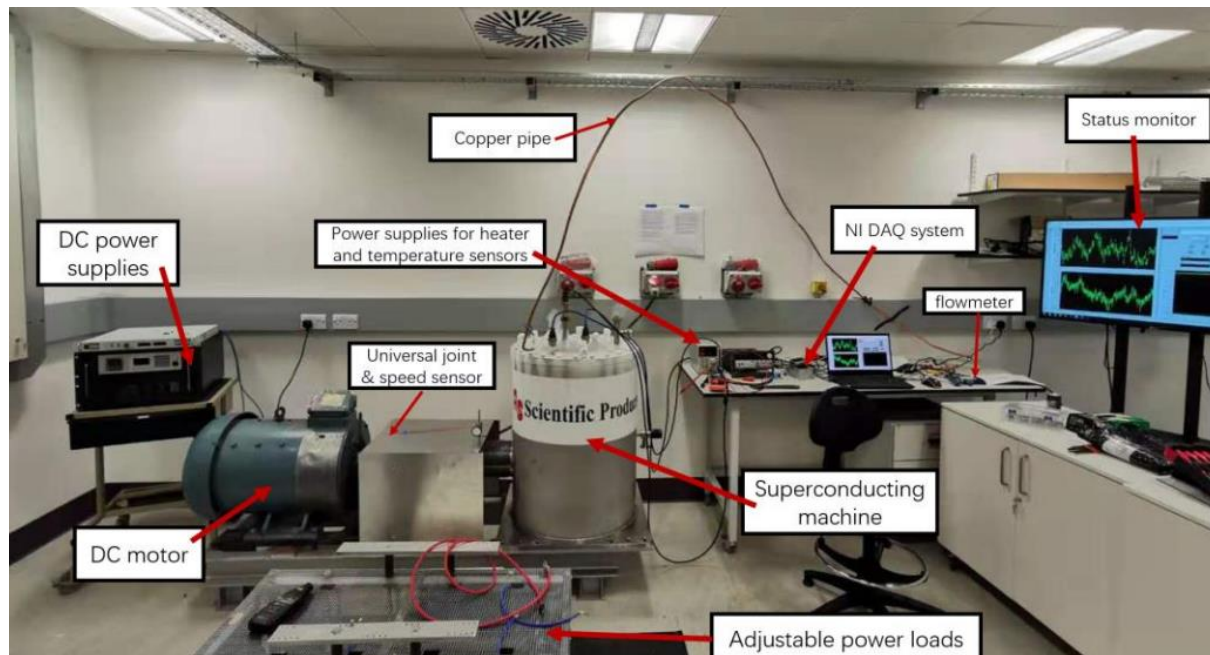

1. AC loss of HTS coils in a rotational field: SUST 33 (10), 104002
2. Transient response of the partially HTS motor: IEEE Access 9, 59628-59636

2022-2025: ZEST 1, in collaboration with Airbus



100 kW cryogenic inverter

Sub-cooled LN2 for stators

Commercial drive system



Neon Thermosiphon
cooling for rotor

Vacuum pump

1. Demonstrate step change for cryogenic/superconducting technologies
2. Demonstrate voltage reduction below 800Vdc for a multi-megawatt applications

2024-2029: ERC SUPERMAN

100 kW fully superconducting motor

Axial flux motor

- HTS brushless rotor : Neon conduction cooling at 40-50 K
- HTS stator* 2: circulated subcooled LN2 at 70-77 K

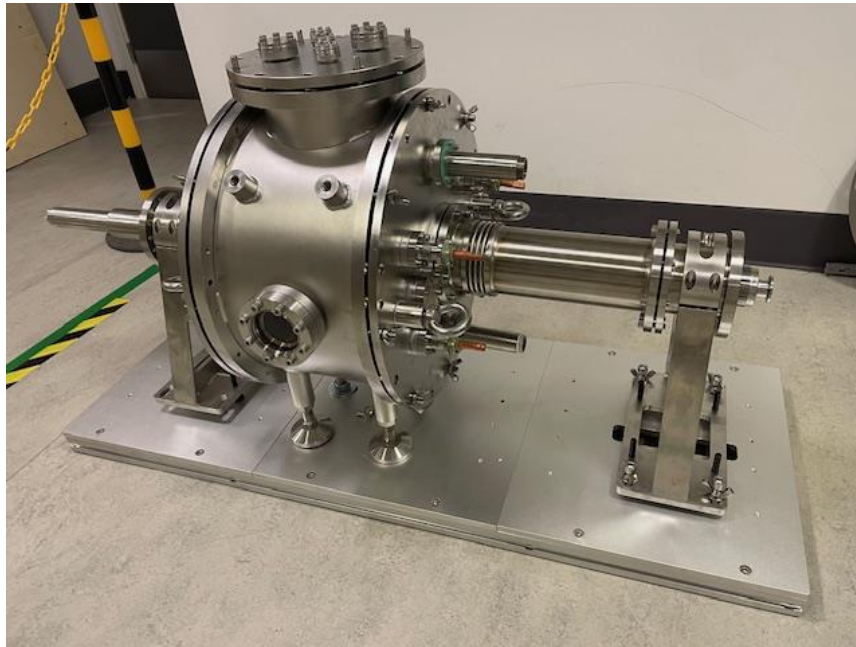

Motor Parameter	Unit	Value
Rated Power	<i>kW</i>	100
Rated Phase voltage	V_{rms}	300
Rated Speed	<i>rpm</i>	1500
Airgap	<i>mm</i>	5
Slot/Pole	--	6/4

100 kW fully superconducting motor

There are two ways to arrange the two HTS armatures:

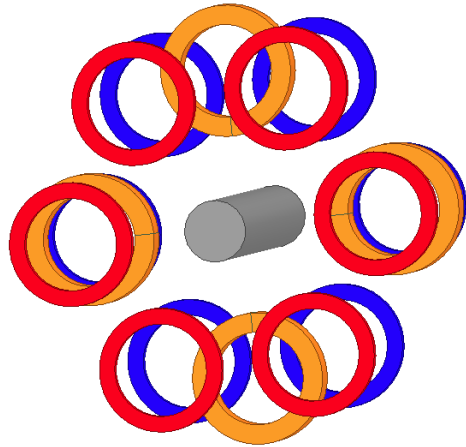

Face-face

Winding Plot 1

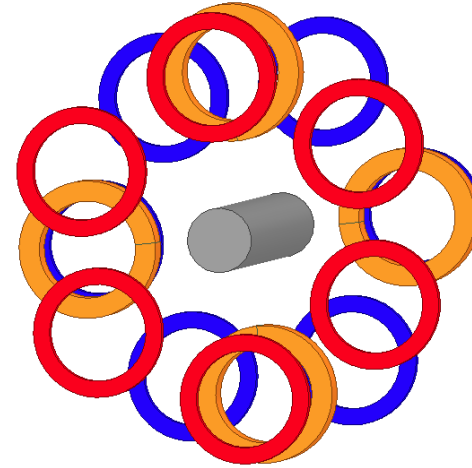
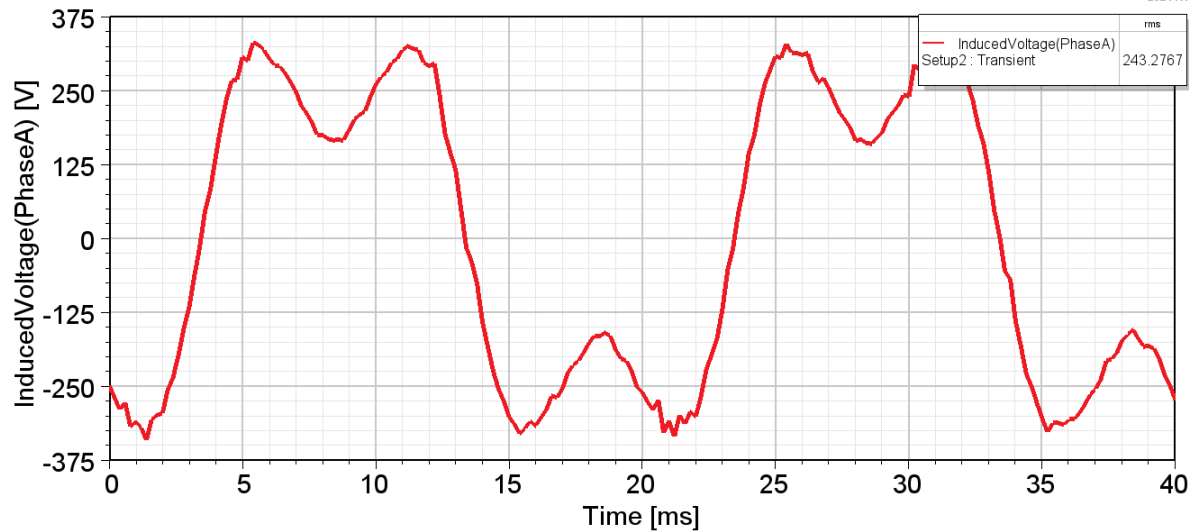

30 deg shift

Winding Plot 2

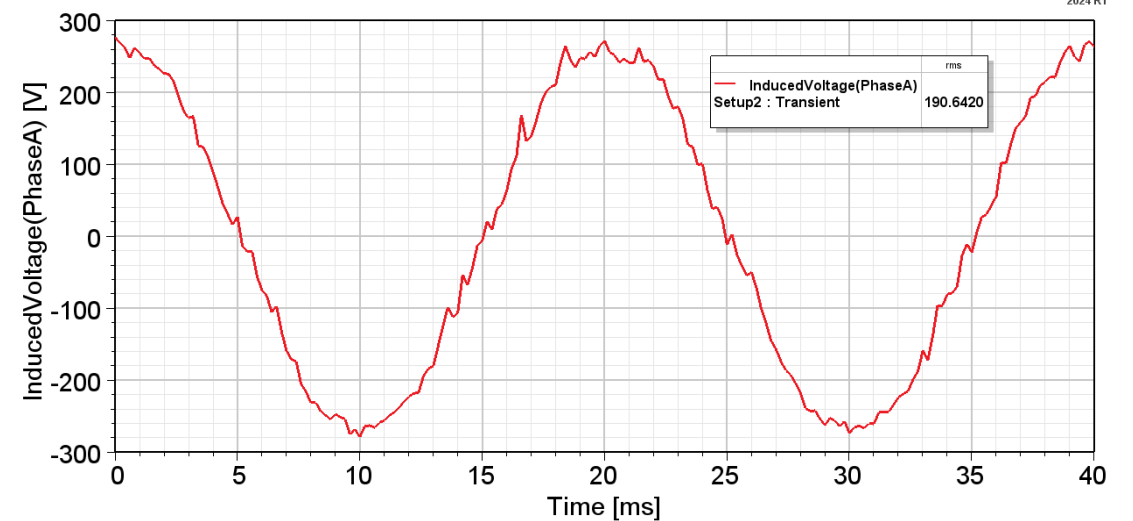

100 kW fully superconducting motor

Cooling system

➤ Motor casing leakage test passed



➤ Sub-cooled LN2 circulation for HTS armature:

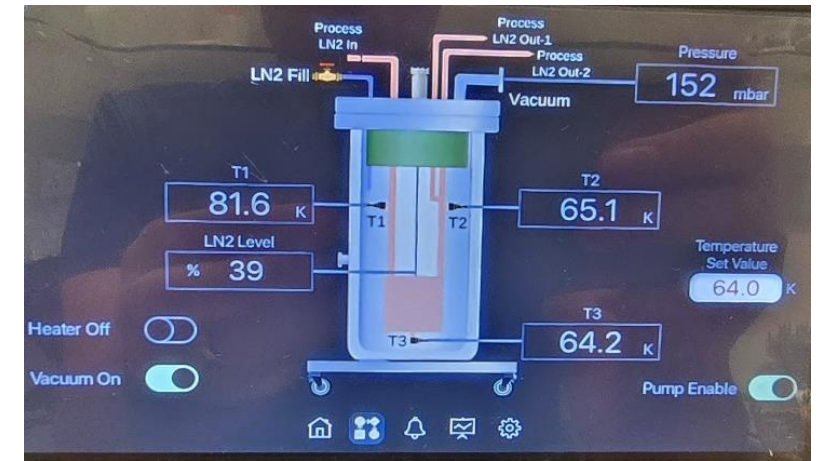

100 kW fully superconducting motor

➤ Rotational thermosiphon cooling for HTS rotor:

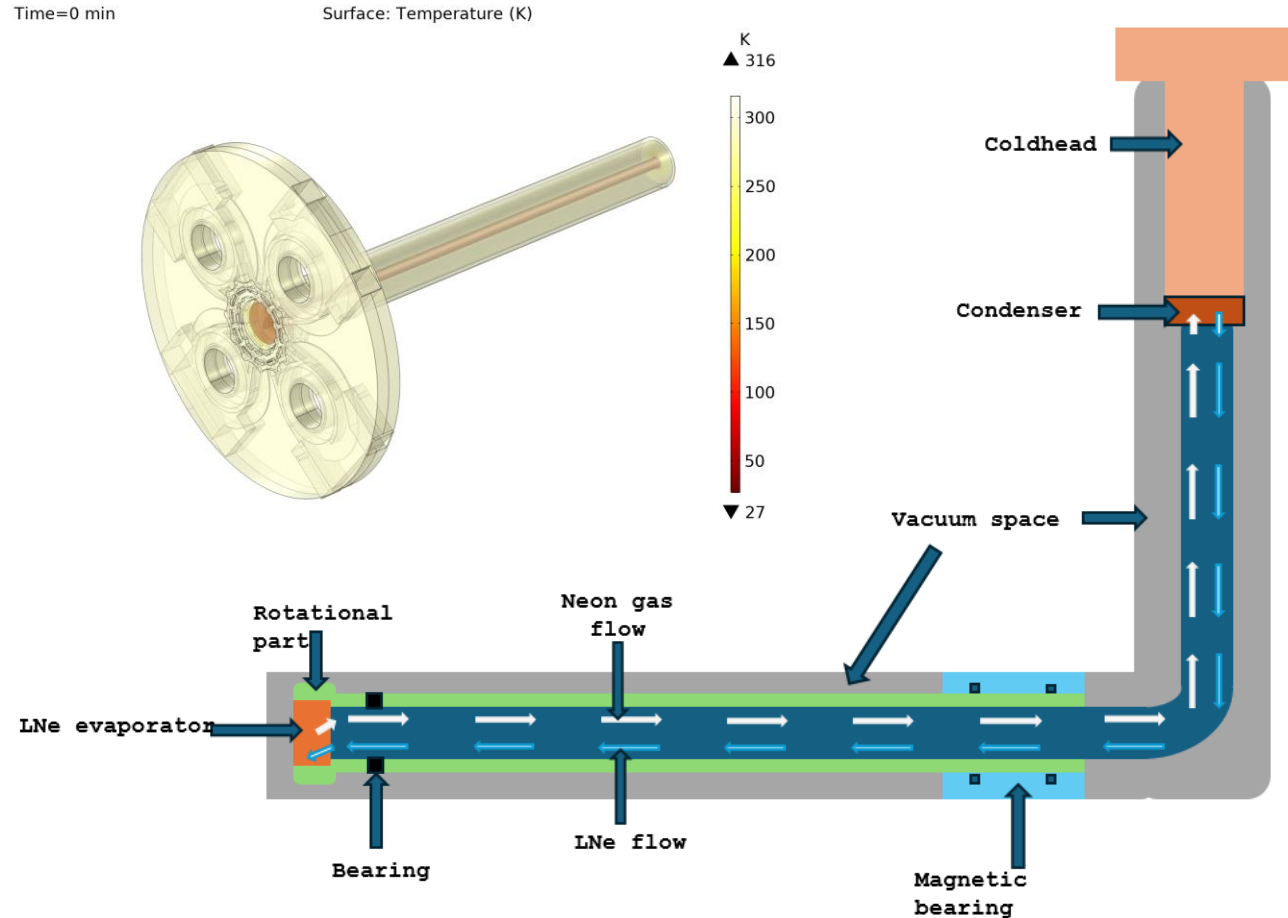

100 kW fully superconducting motor

➤ Cooling the rotor without thermal insulation layers:

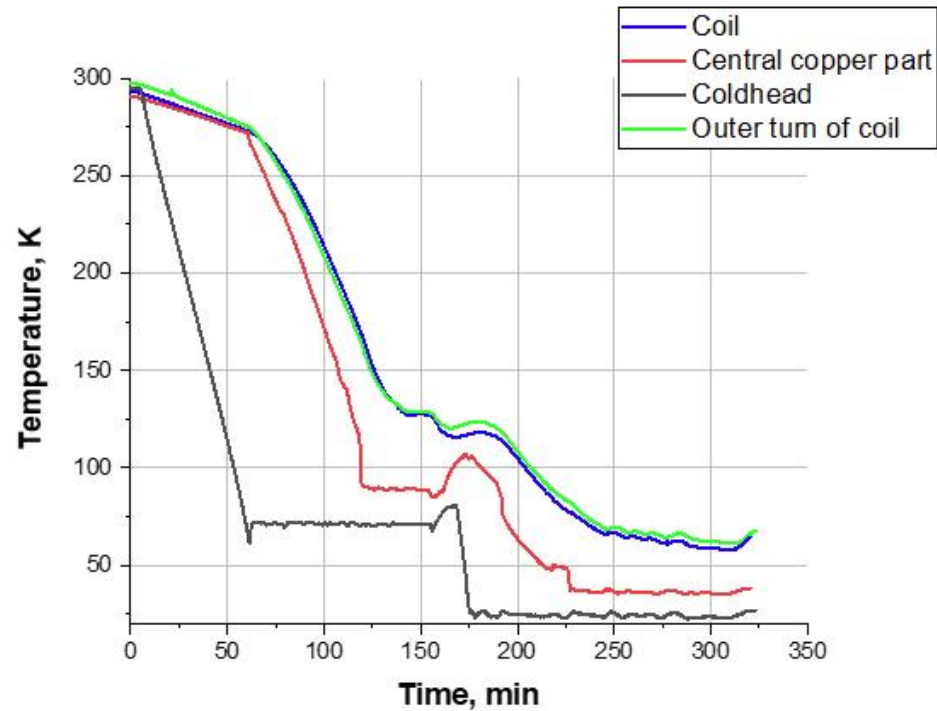

Location	Minimum stable temperature with active cooling (K)
Coil	58.24
Central copper Hub	35.34
Coldhead	23.26
Outer turn of Coil	62.54

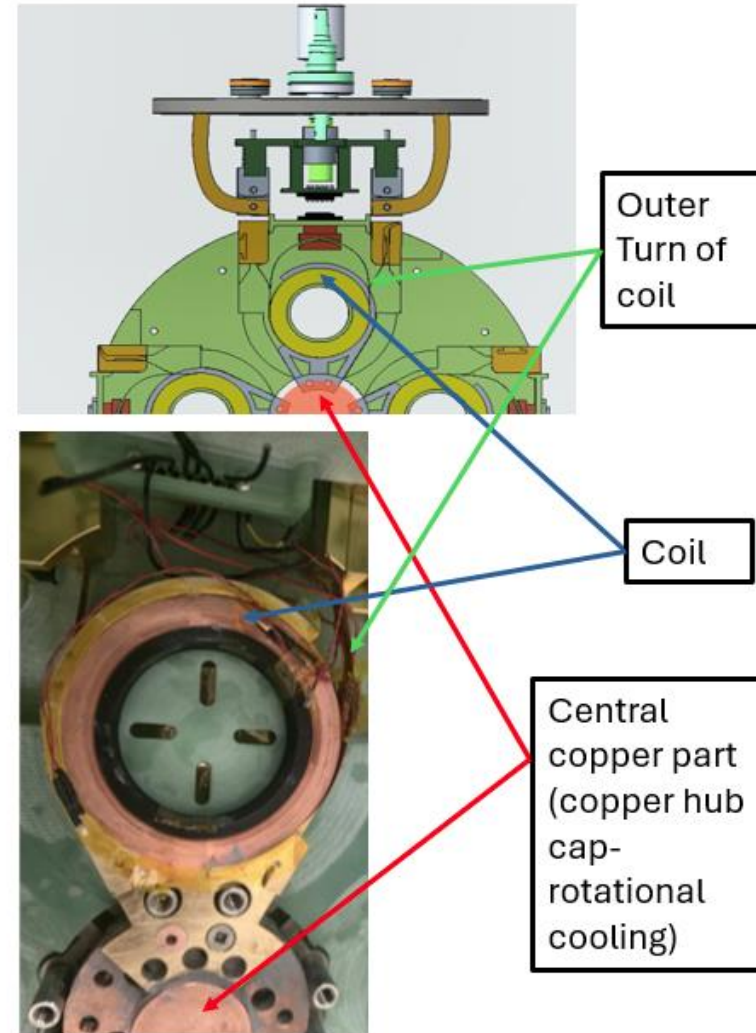

100 kW fully superconducting motor

HTS stator/armature:

- Two stator disks were developed and tested: dry winding vs wet winding

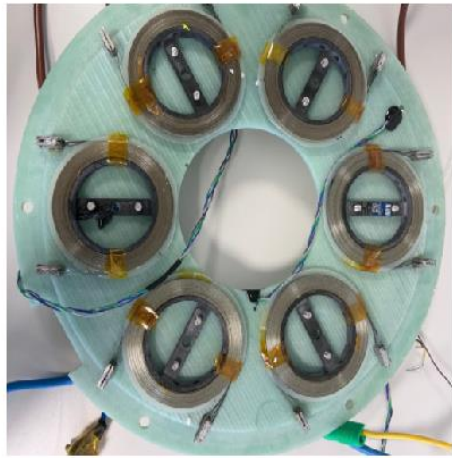

(a)

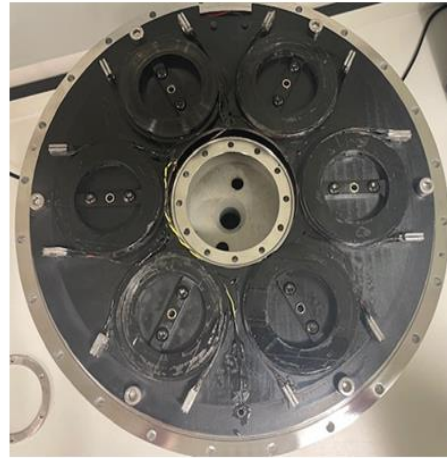

(b)

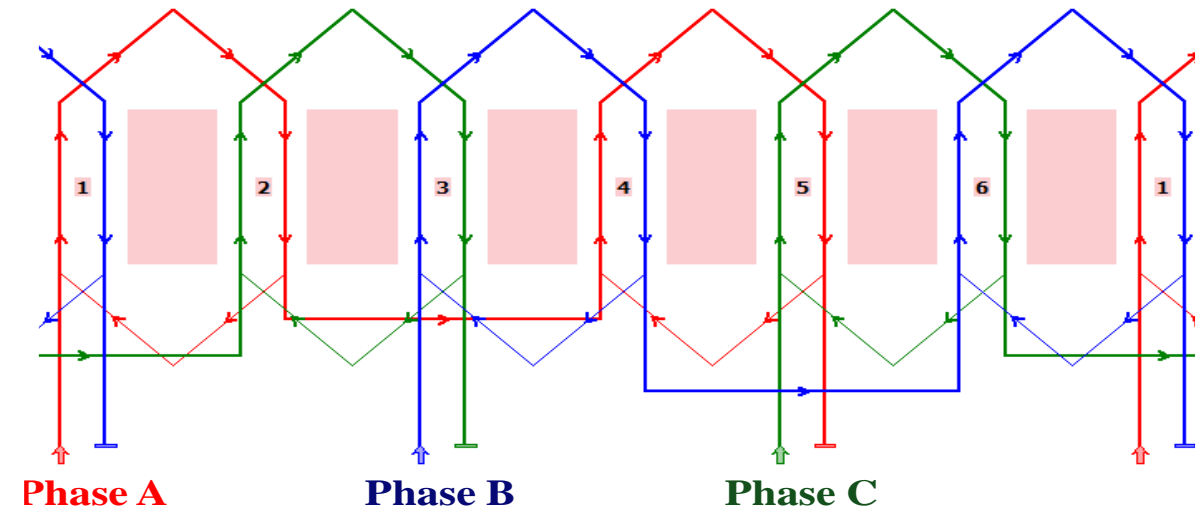

Each cable turn has four 4mm HTS coated conductor

Motor design updates

HTS Stator

➤ Ic tests at 70 K and 77 K:

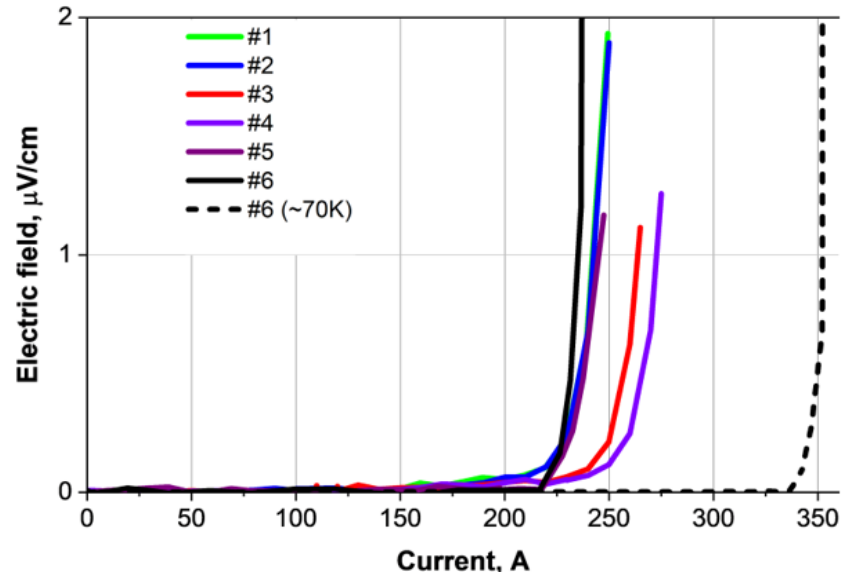

All coils have I_c above 220 A at 77 K.

When further cooled down to 70 K, I_c is above 350 A.

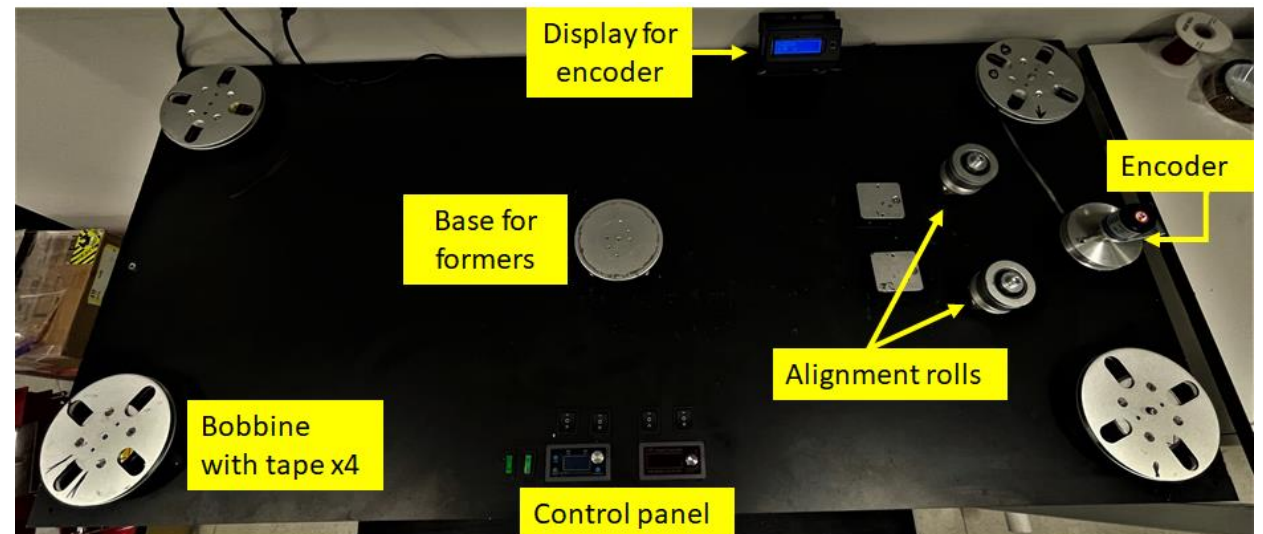
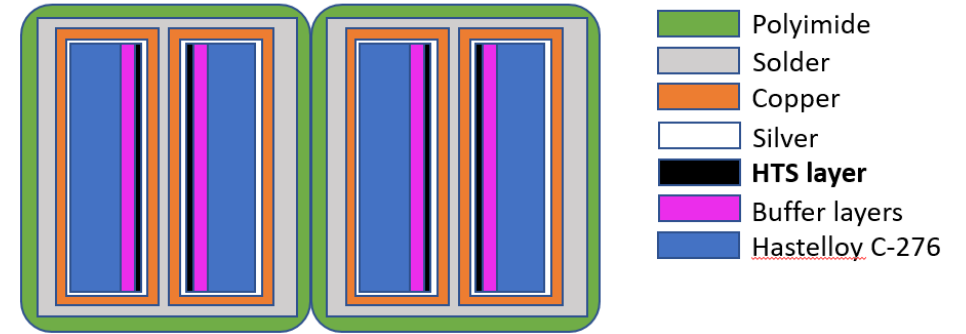
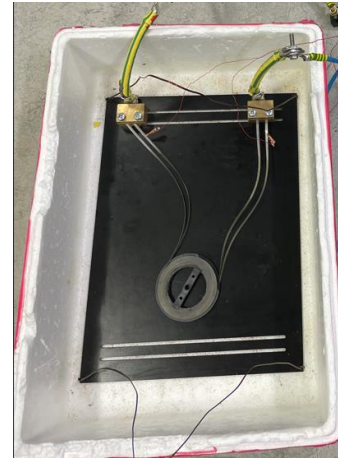

Motor design updates

HTS Stator

- AC loss measurement and calculation at 20-77 K *:

Sat-Af-Or5-06: AC loss measurement for parallel-wound HTS coils

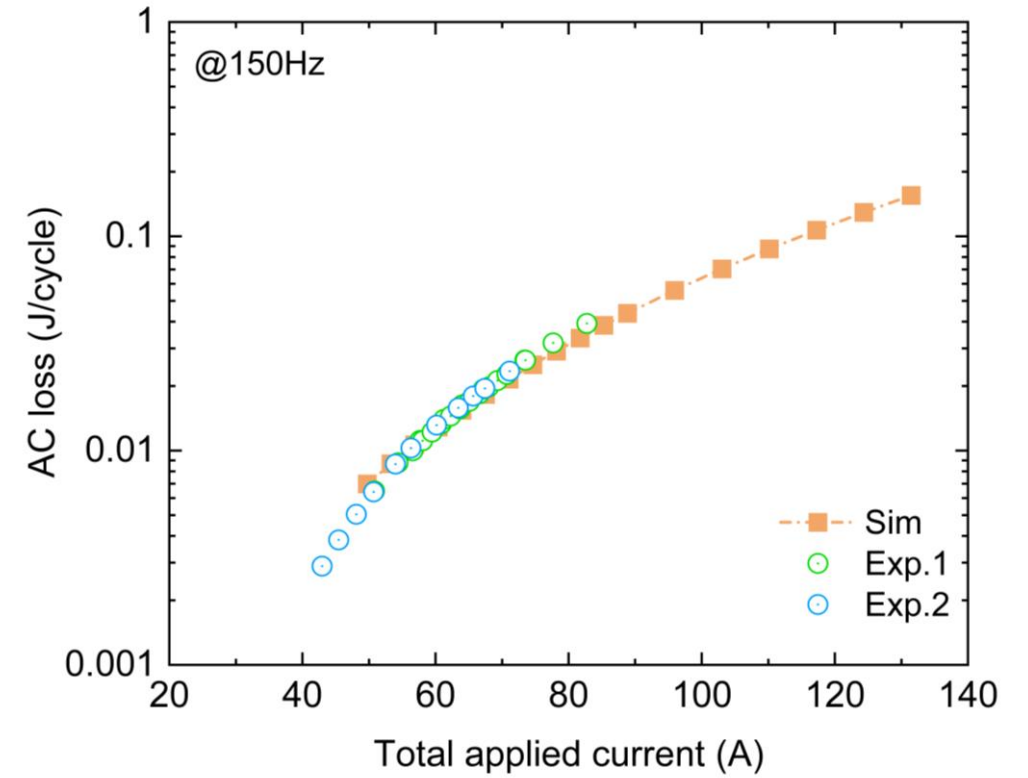
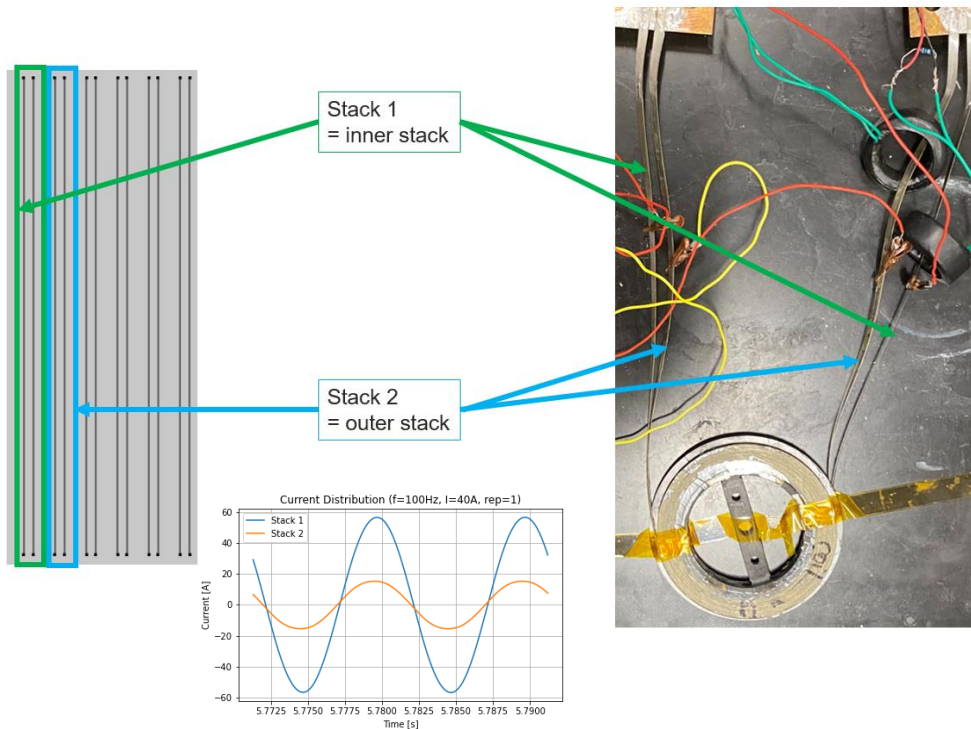

Motor design updates

➤ Insulation test up to 1kV:

Voltage applied between armature
and motor casing

No leakage current up to 1 kV

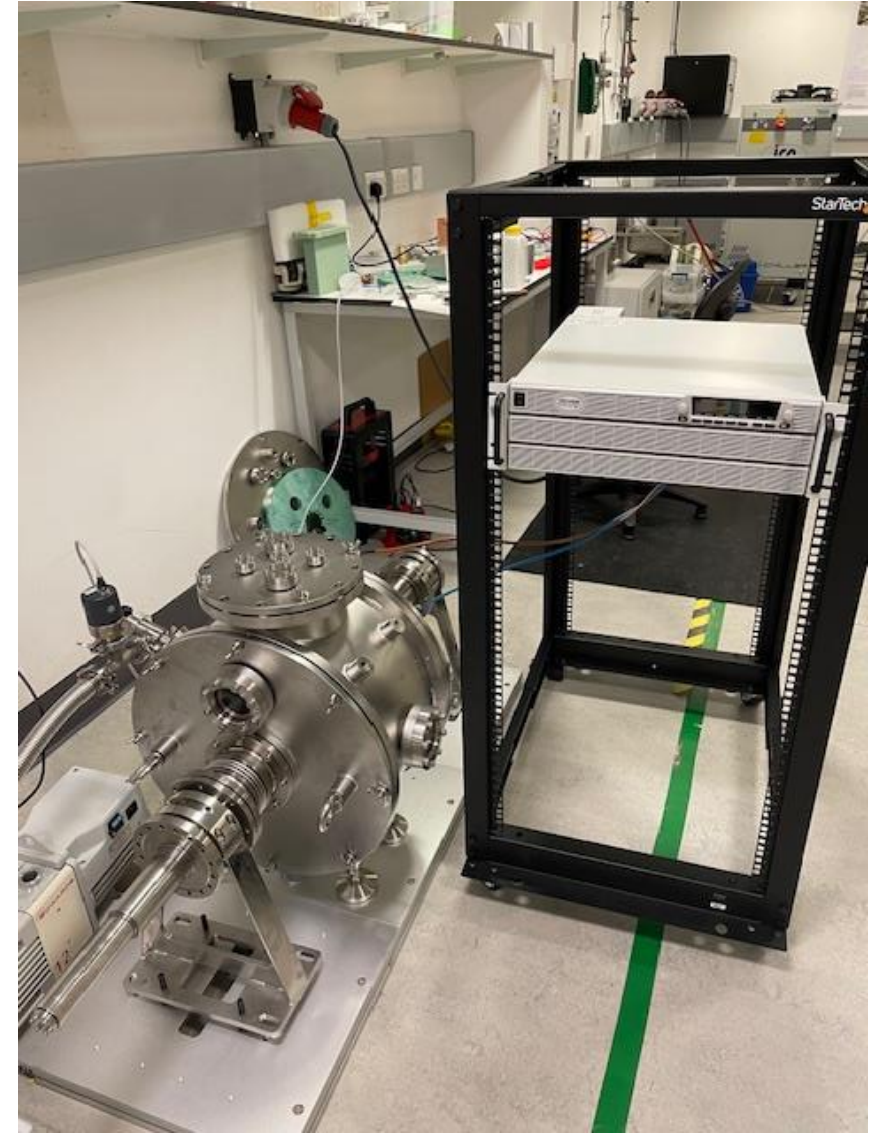

Motor design updates

➤ Room temperature rotational test with a PM rotor:

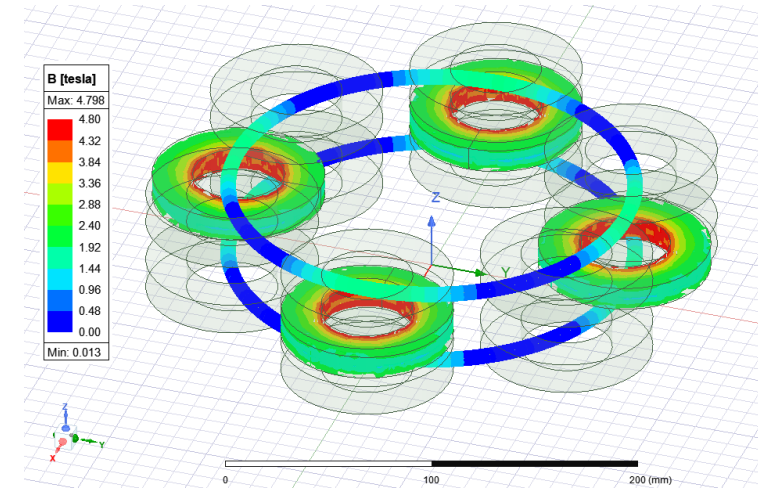
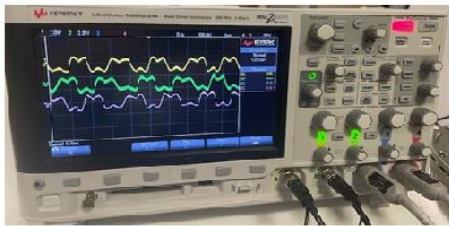
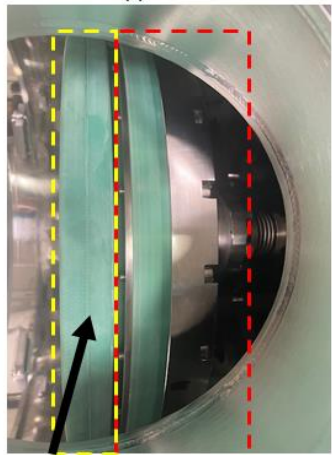
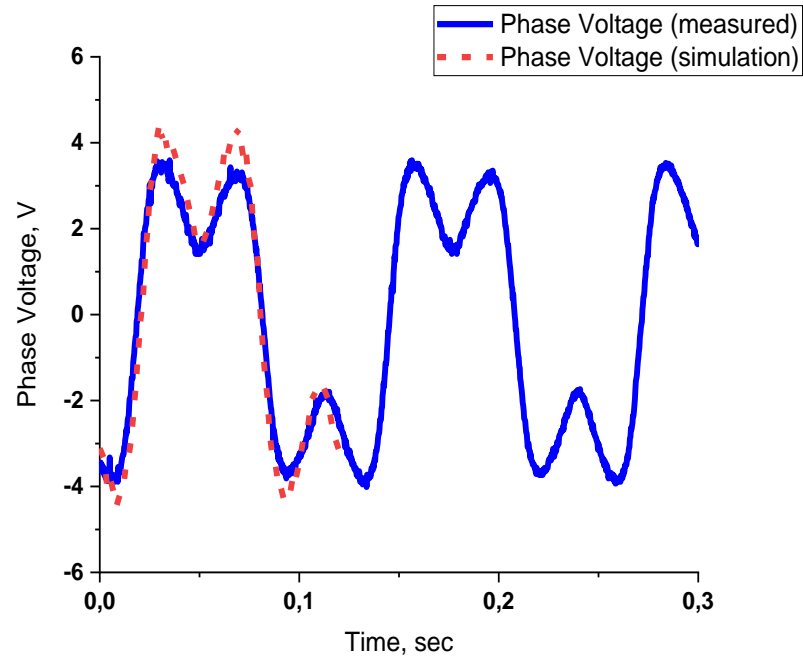
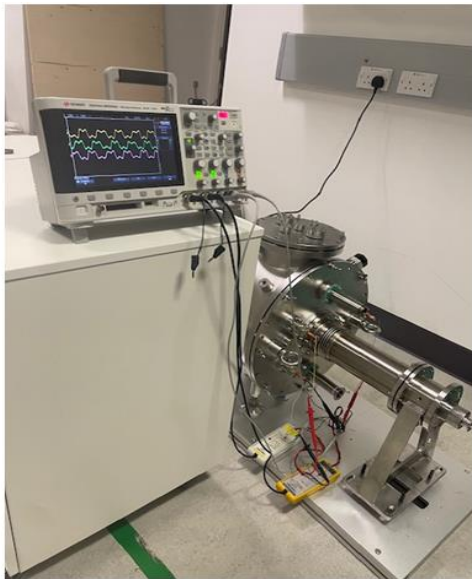
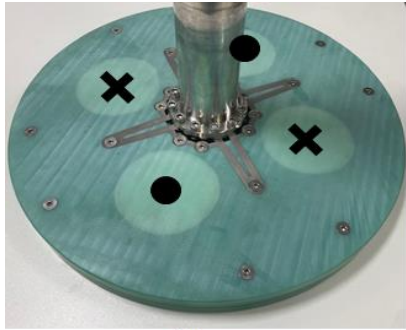

Open voltage output agrees with FEM 3D simulation

Motor design updates

➤ First 77 K first test failed:



(a)

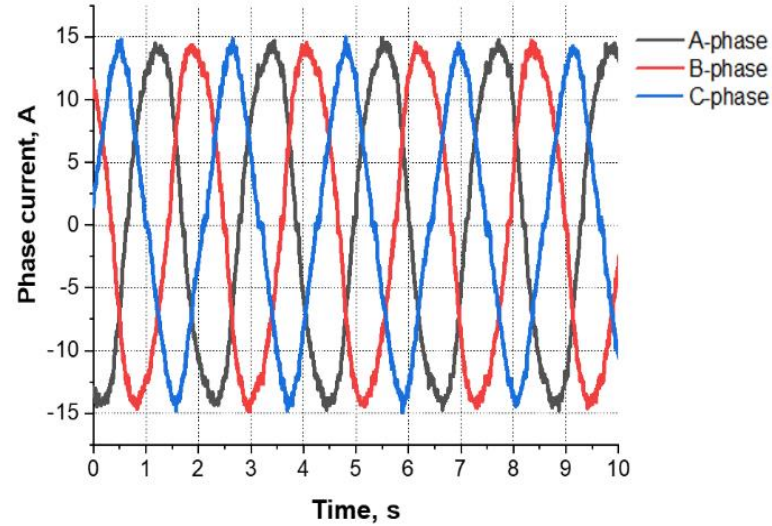

(b)



- Coolant leakage due to G10 casing sealant problem. Top coil was burnt

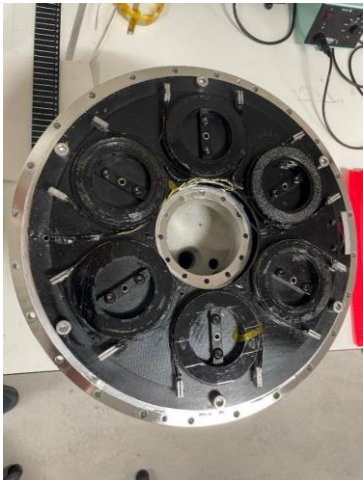

Lessons learnt:

1. Better sealing
2. Real-time T monitoring

Motor design updates

- Second rotational test was successful @ 70 K, 1500 rpm:

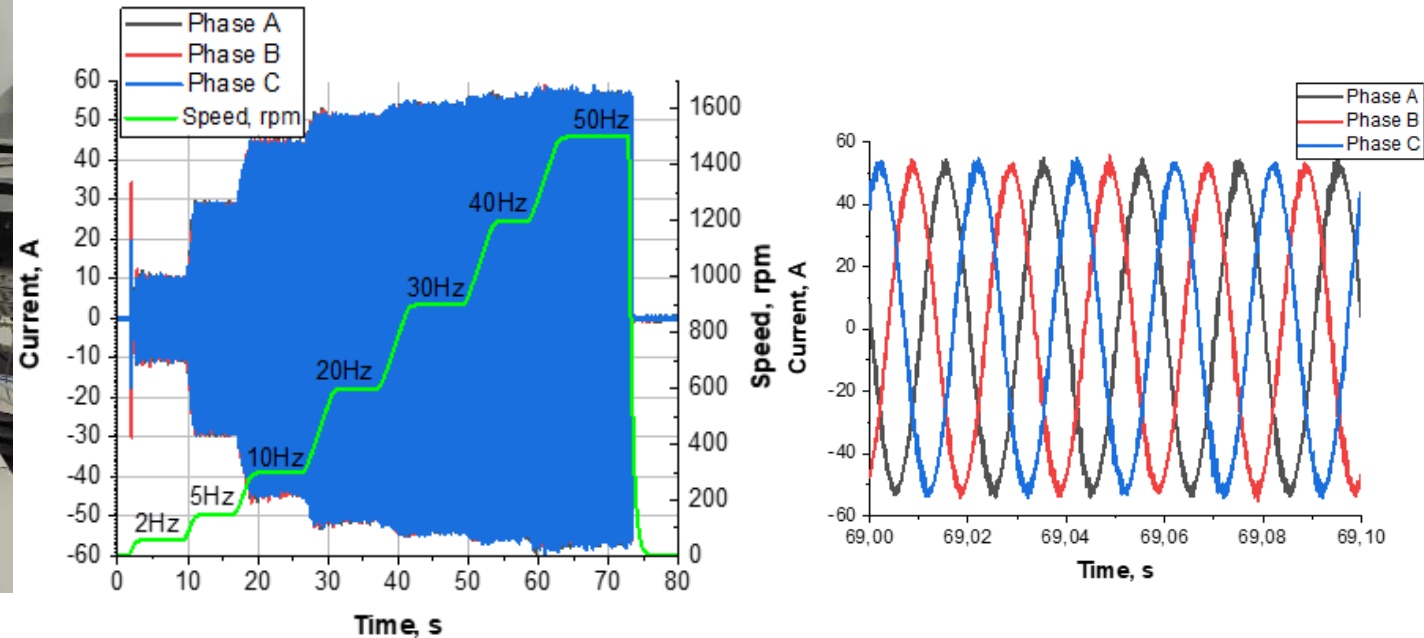
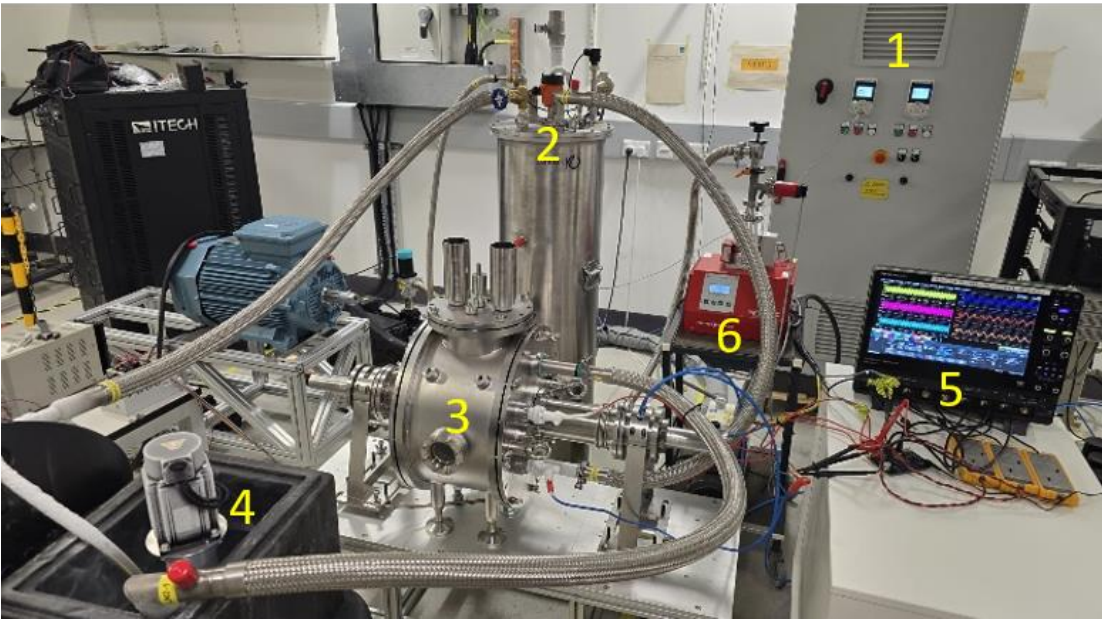

Test setup with closed loop subcooled LN₂ circulation and PM rotor: 1) inverter, 2) subcooled LN₂, 3) HTS motor with a PM rotor, 4) cryogenic pump and LN₂ reservoir, 5) oscilloscope, 6) vacuum pump.

Closed loop circulation with flow up to 10 l/min and subcooling down to 70K which was achieved during the test.

Motor design updates

HTS motor operation at 1500rpm

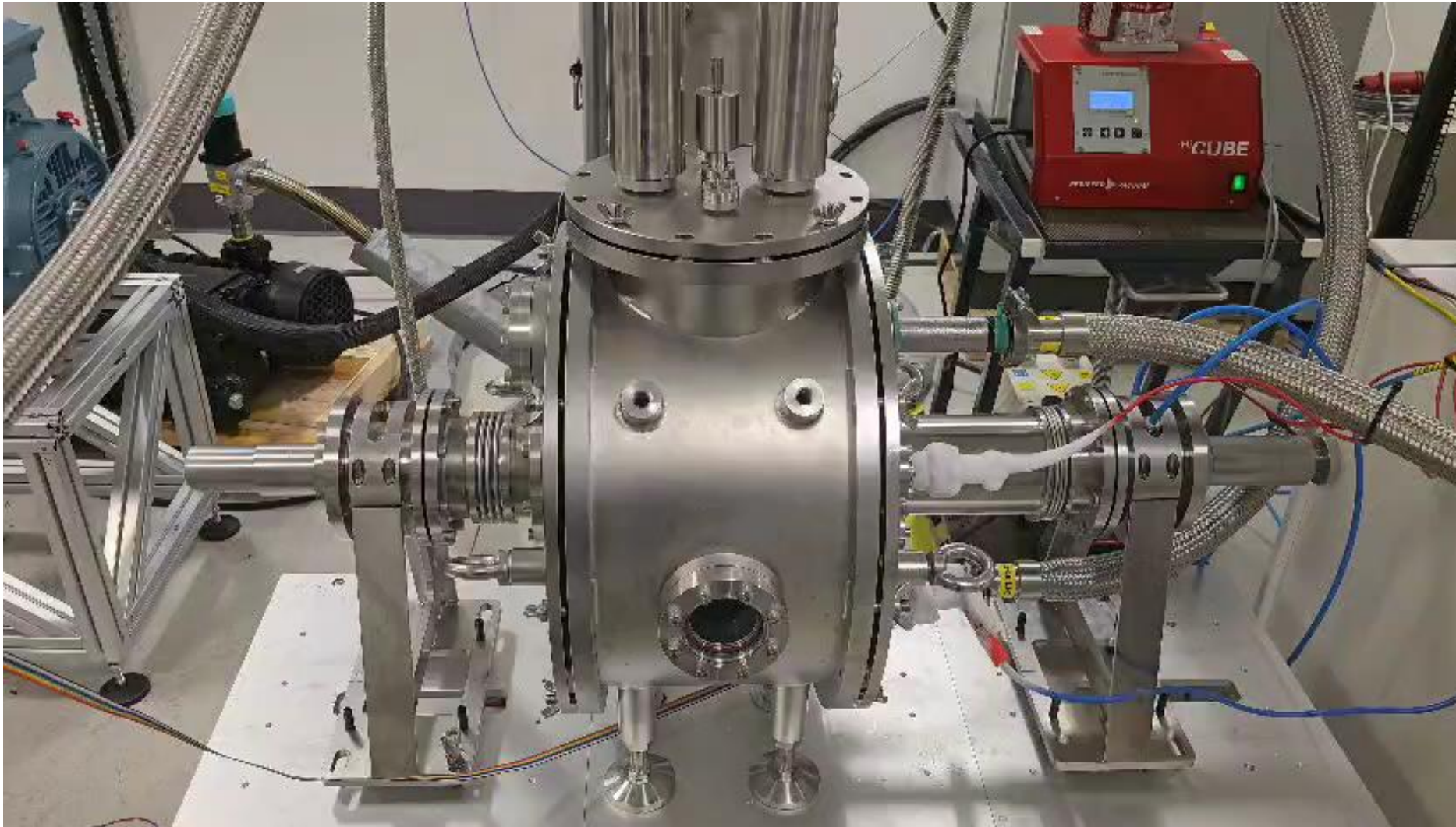

Motor design updates

HTS rotor: Low joint HTS resistivity + direct charging/dynamo-flux pump

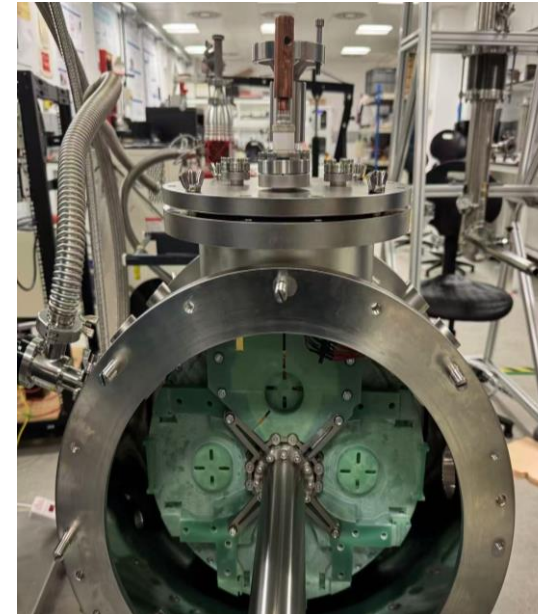
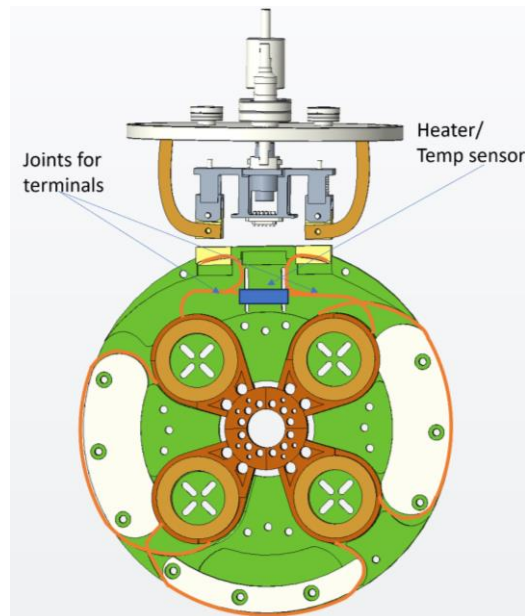

- We need nΩ level HTS joints for this rotor at 50 K

Charged current	500 A
Inductance	2640 μH
Resistance	10 nΩ
Temperature	50 K
3 hour decay	1.48T -> 1.42T 4.1%
10 hour decay	1.48T -> 1.29T 12.8%

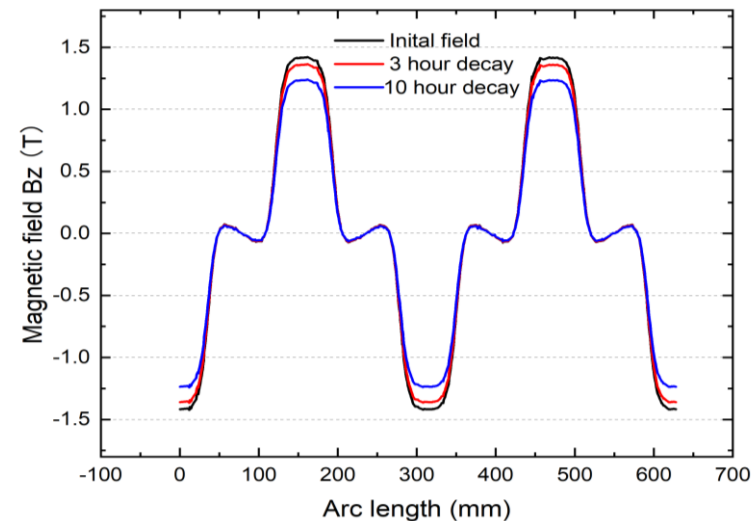

Motor design updates

HTS rotor:

Customized heating-press

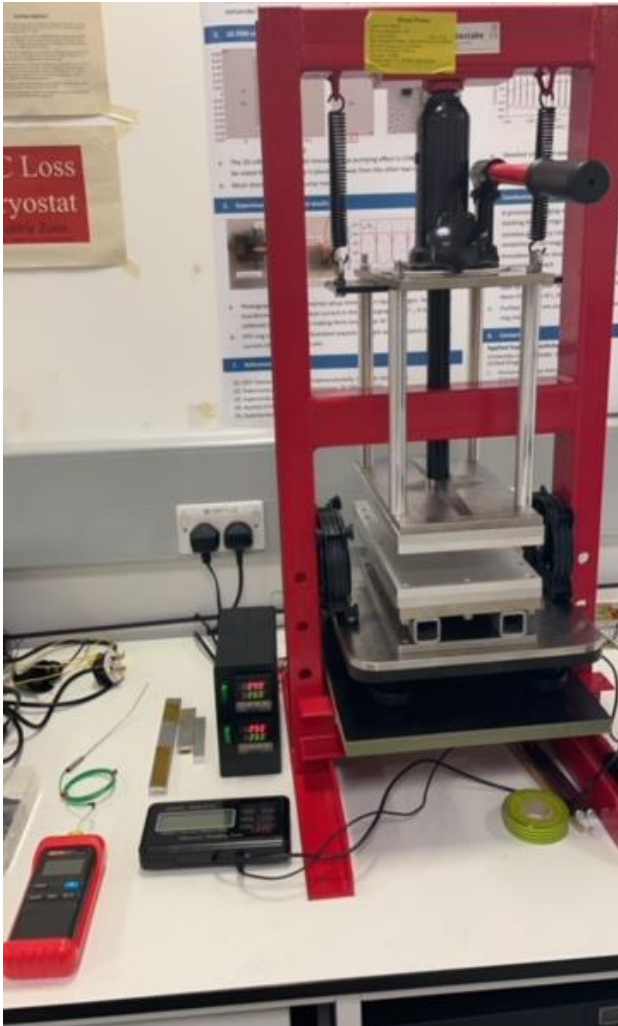

Temperature-pressure optimization for 5 cm long soldered joints with 12mm HTS tape

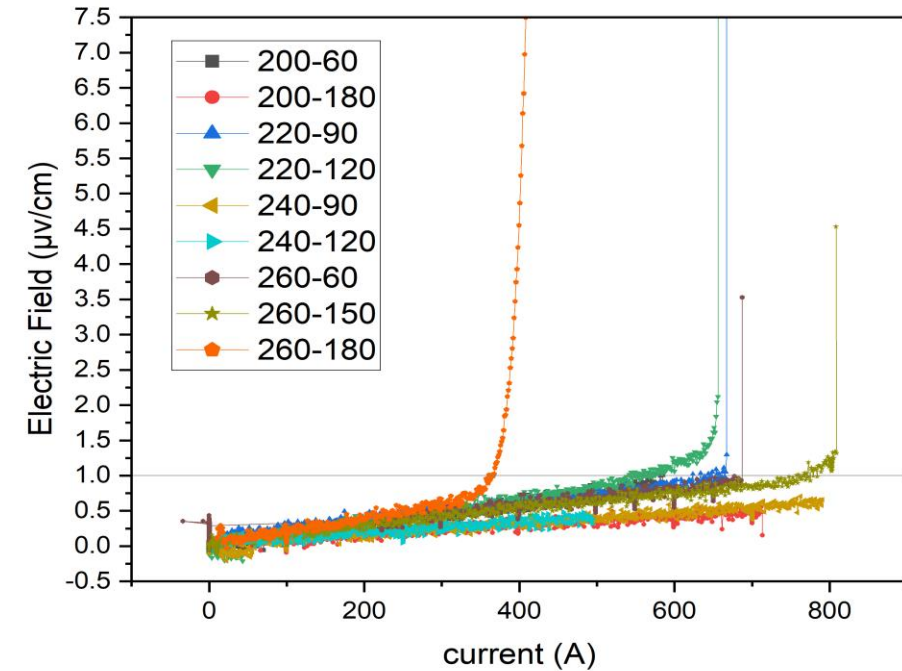
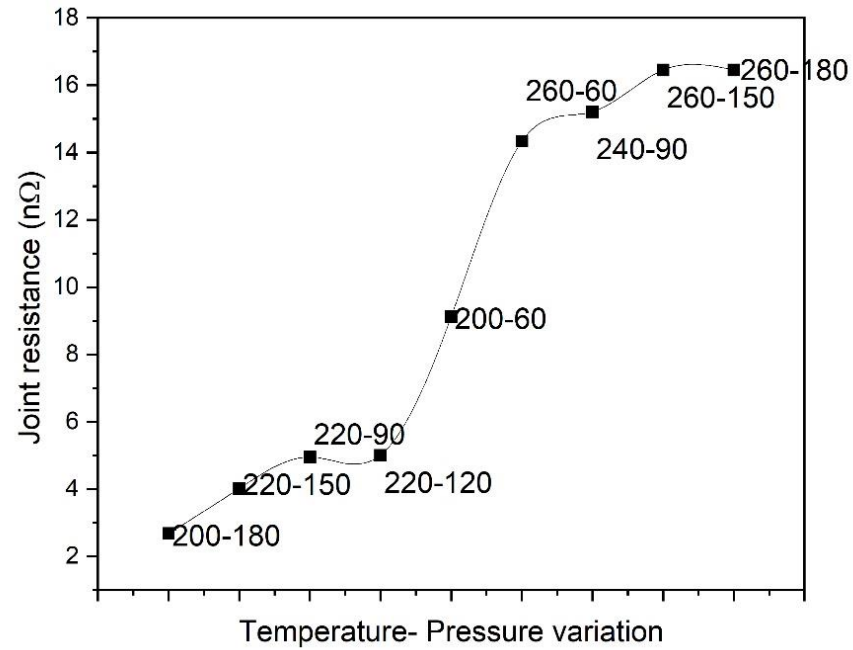

- nOhm level resistance was achieved at 77 K
- I_c measurements were performed for all joint samples

Motor design updates

HTS rotor: Dynamo-flux pump for demagnetization

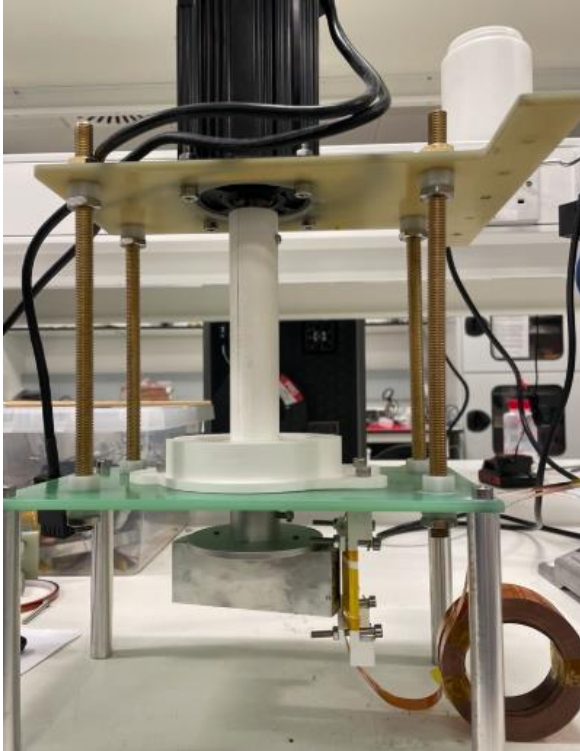

**Wireless charging
during rotation of
rotor**

Results of the HTS coil charging
with persistent current mode

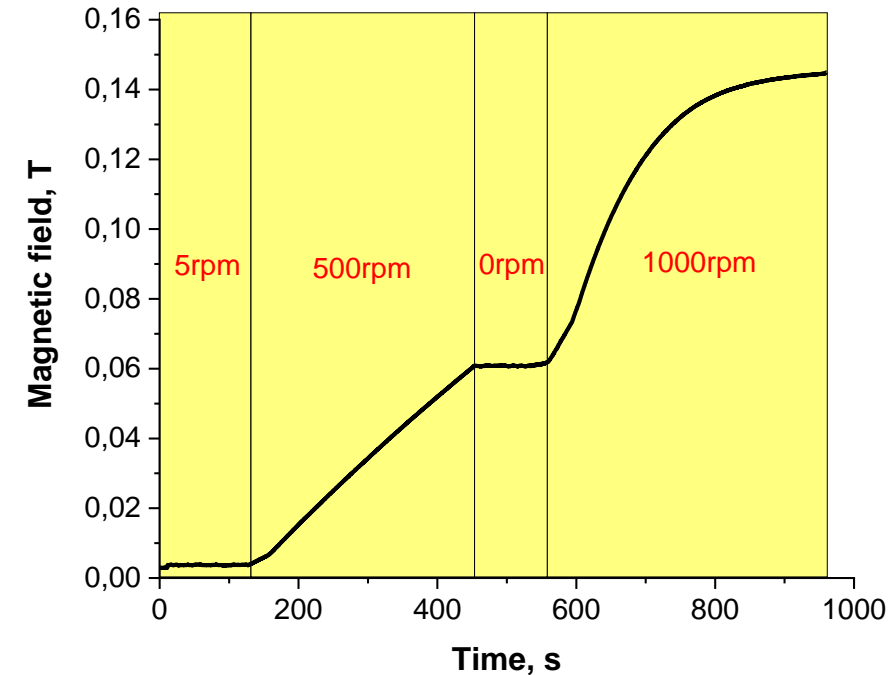

- No degradation of current at 0 rpm for low resistance of the joint.
- At 77 K, 0.04 T/100 s
- Feedback control will be used for field stability [1]

[1] [Feedback-controlled flux modulation for high-temperature superconducting magnets in persistent current mode](#), M Iftikhar, M Zhang, W Yuan, Superconductor Science and Technology 36 (5), 055008

Cryogenic inverter: why cryogenic?

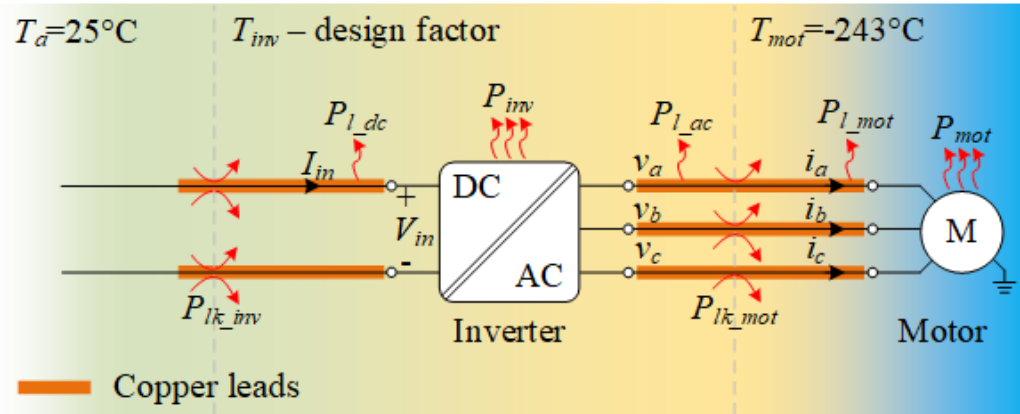

Inverter's loss is mainly affected by:

- Topology of circuit
- Type of power semiconductor
- **Coolant temperature!**

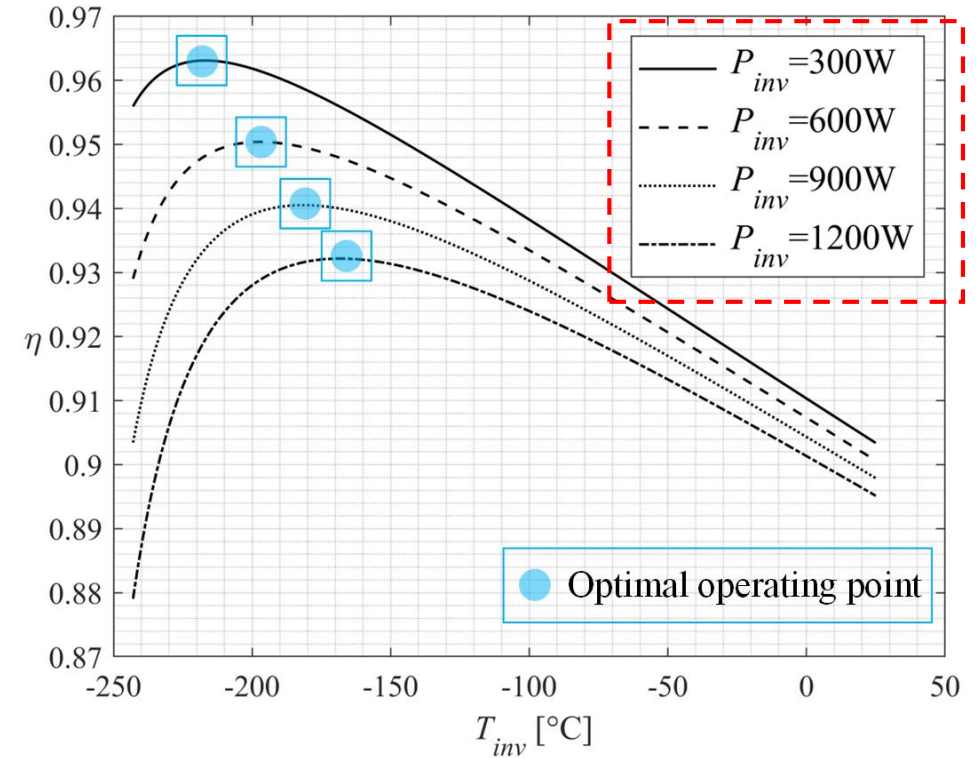

Cryogenic inverter: component overview

Specification:

- DC bus voltage: 730V
- Operating temperature: 77K
- Efficiency: >96%
- THD: <4%
- Switching frequency: 5kHz

Topology:

- Three-level voltage source
- Si IGBT power module

Customized gate drive circuit:

- Cryogenic tested
- Fault detection

Output filter:

- Cryogenic inductors
- Motor dv/dt protection

Analog & digital signal interface:

- Cryogenic tested

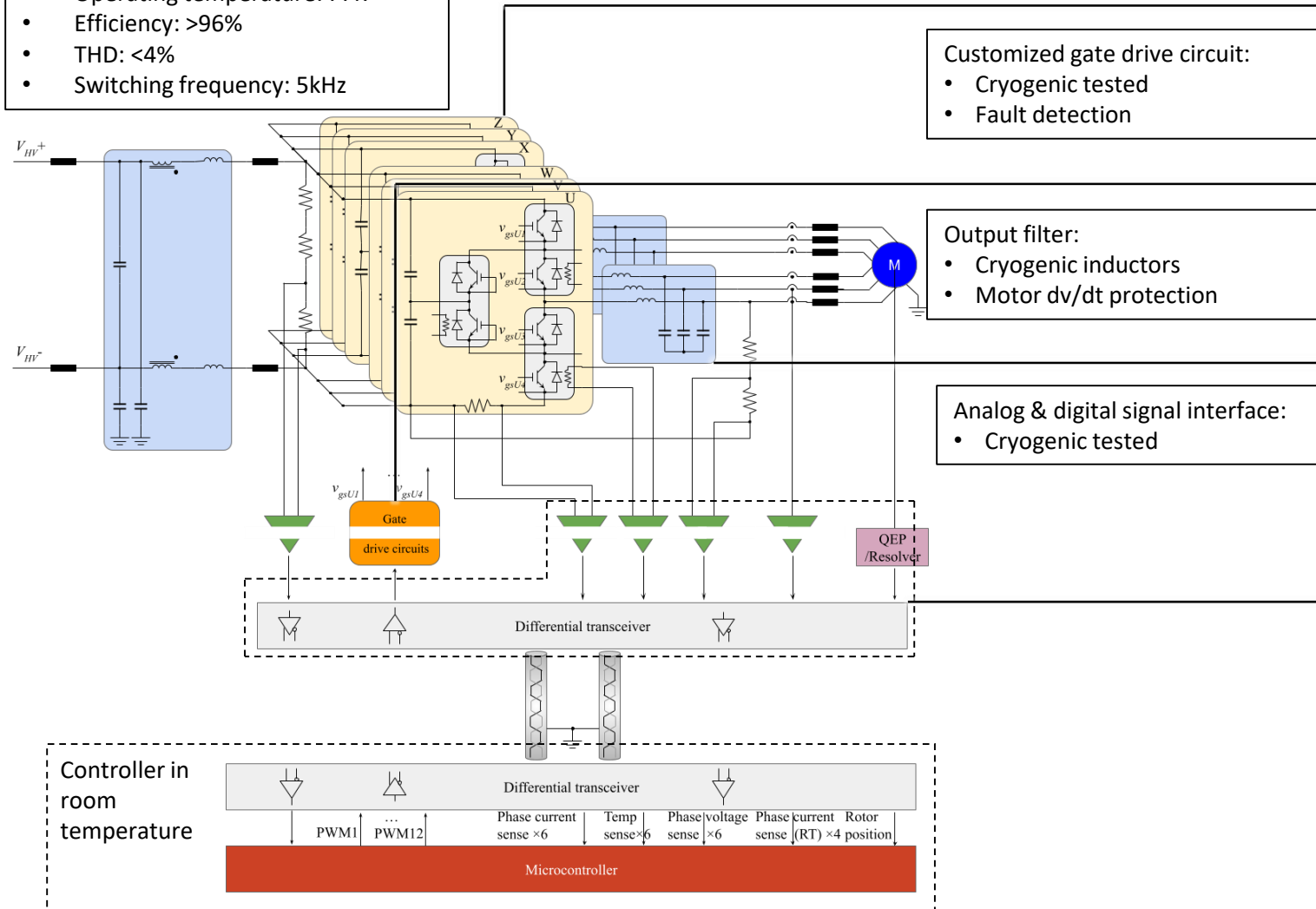
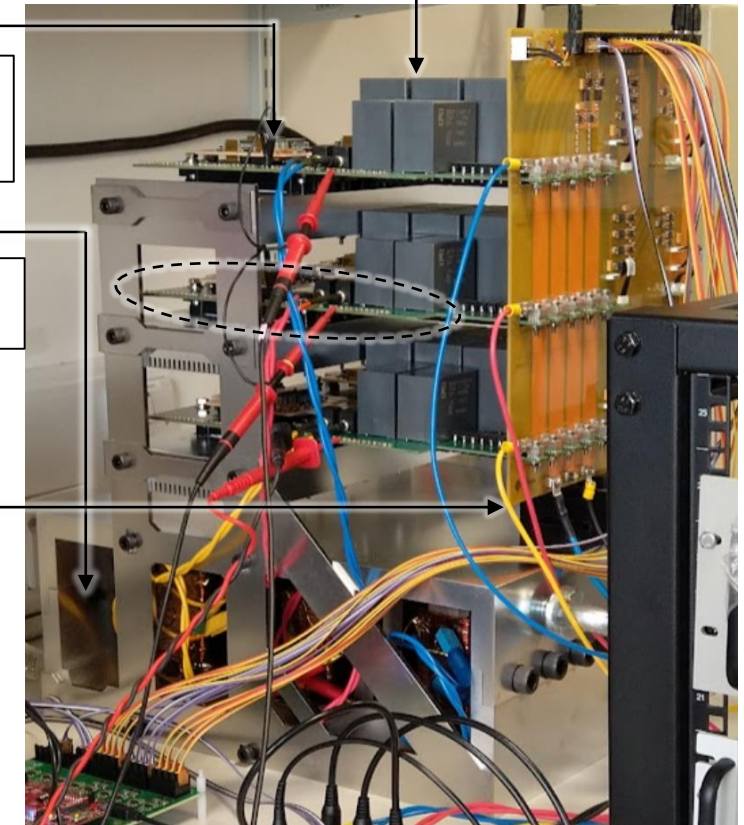

Cryogenic inverter: cryogenic isolated gate drive

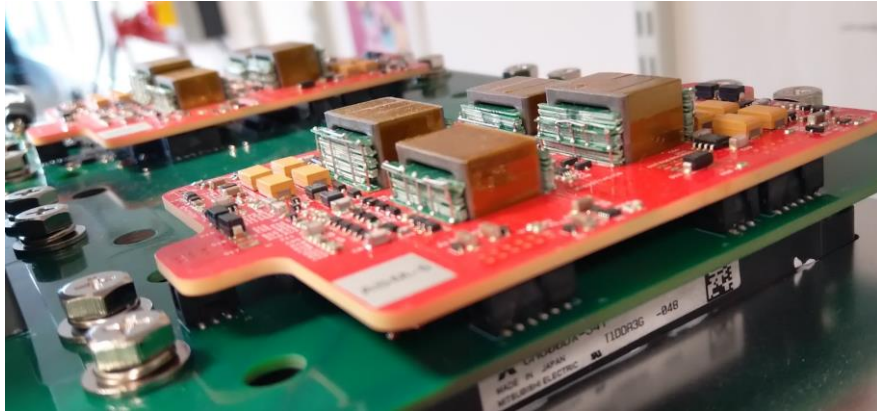

Two gate drive boards (version 2)
mounted on a phase board of
the inverter

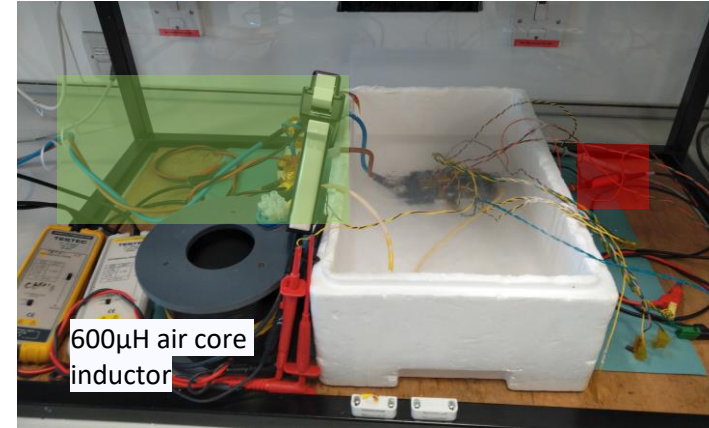

IGBT power module tested at 800V/160A in 77K.

A half-bridge three-level inverter is tested up to 700V- and 600V-input voltage at room and cryogenic temperature, respectively: 20Ω resistive load, 10 kHz switching frequency.

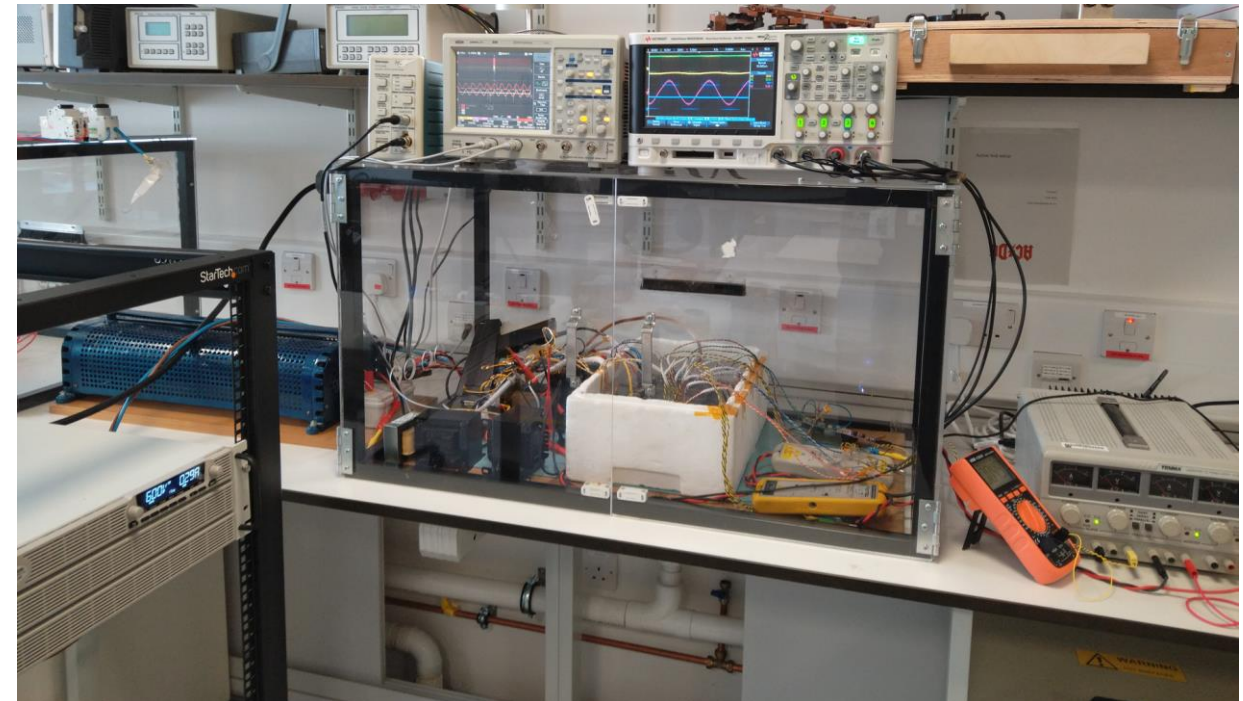

Cryogenic inverter: test progress

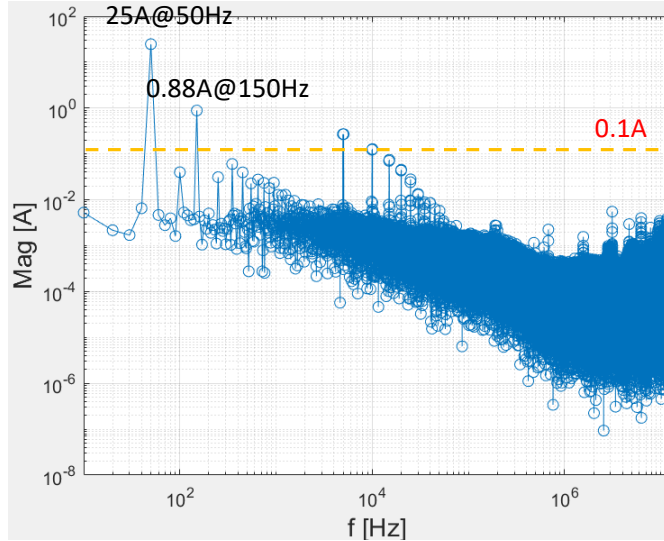

Spectrum of Phase-A current
THD 3.6%
(Target THD 4%)

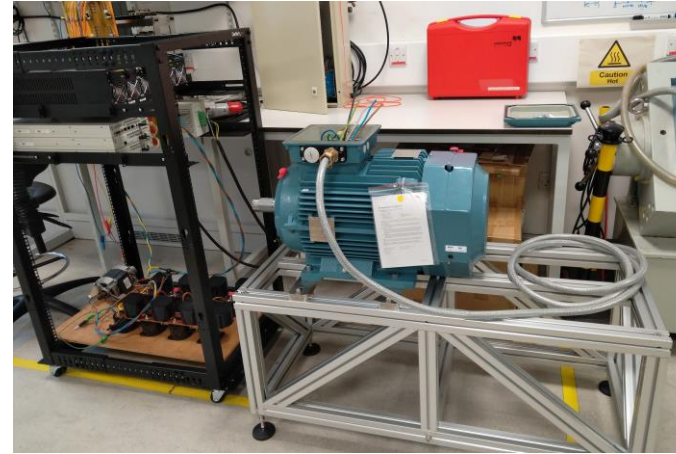

Test with an induction motor before connecting to HTS motor

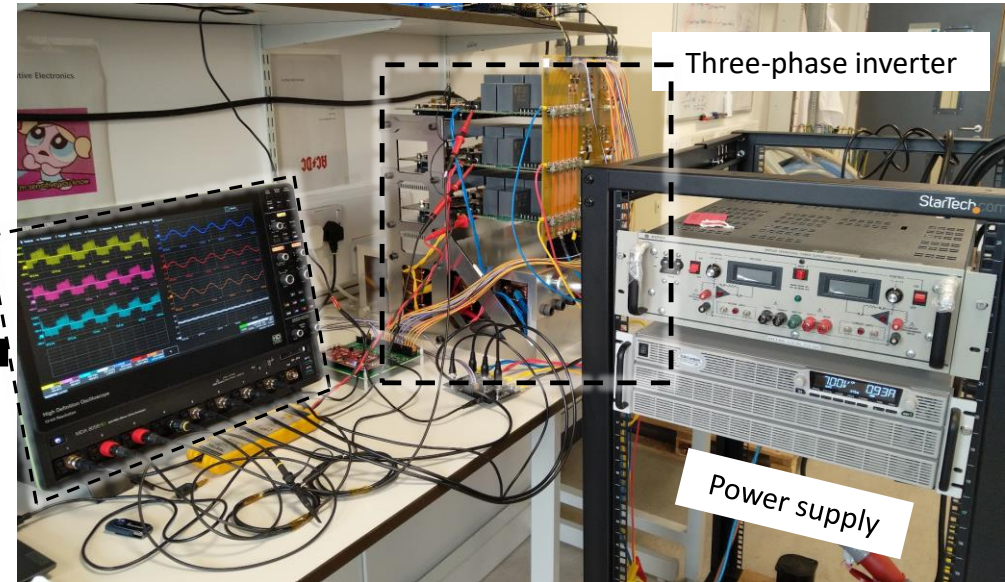
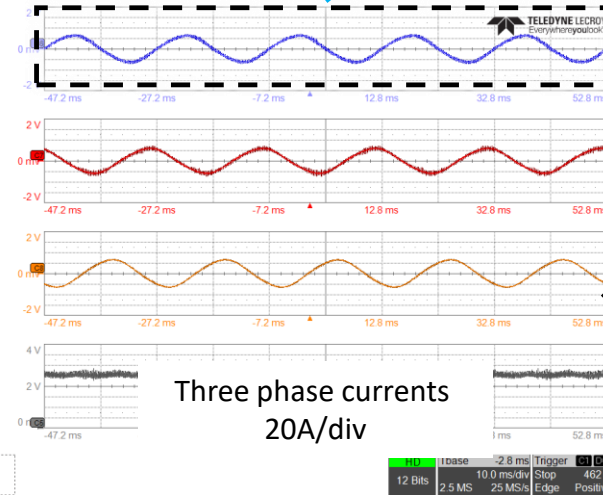
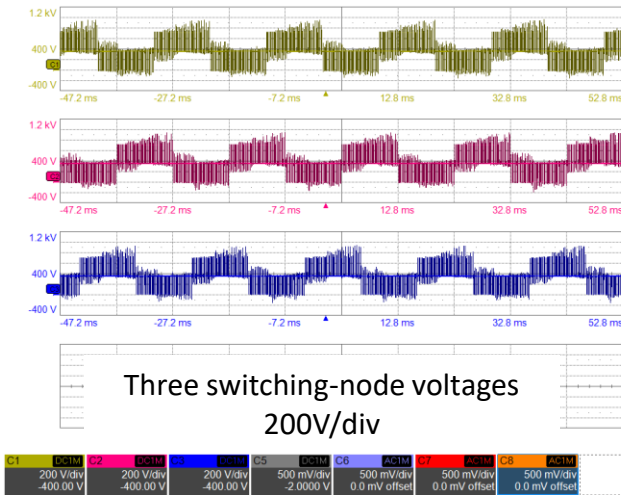

RT three-phase inverter test:

@ 700V input voltage and 25A-peak phase current, equivalent to operation at 18kW

- 1) A R&D platform for exploring novel technologies
- 2) Easy access and diagnoses
- 3) Proof-of-concept for a fully HTS motor

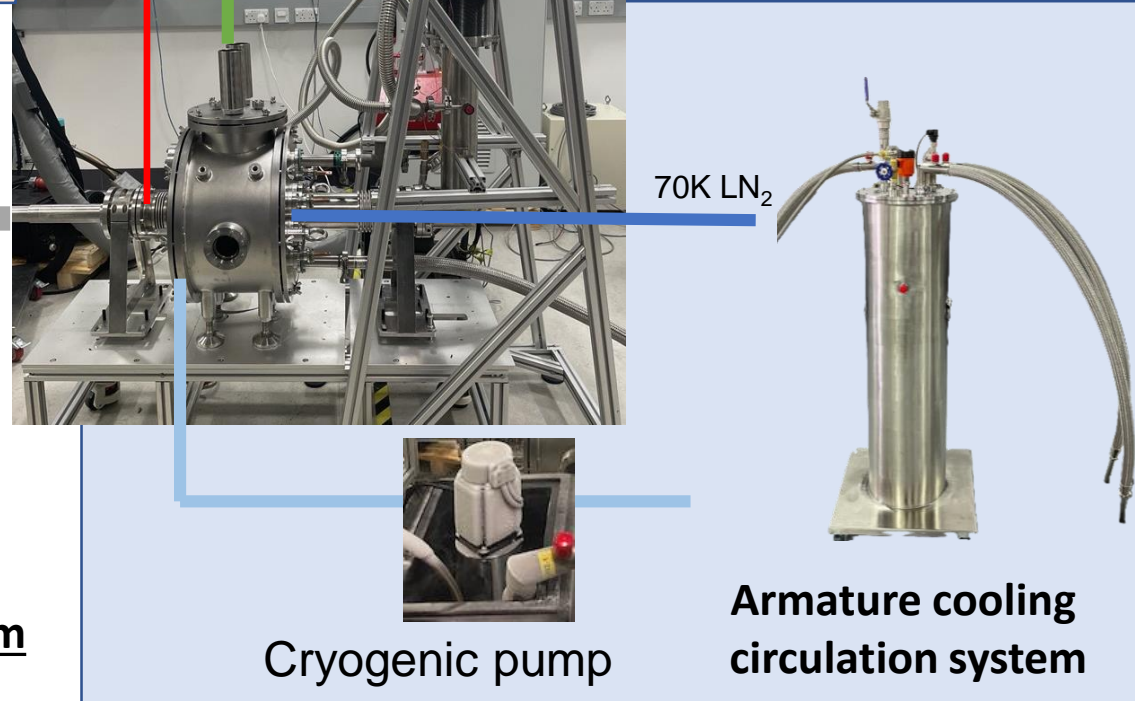
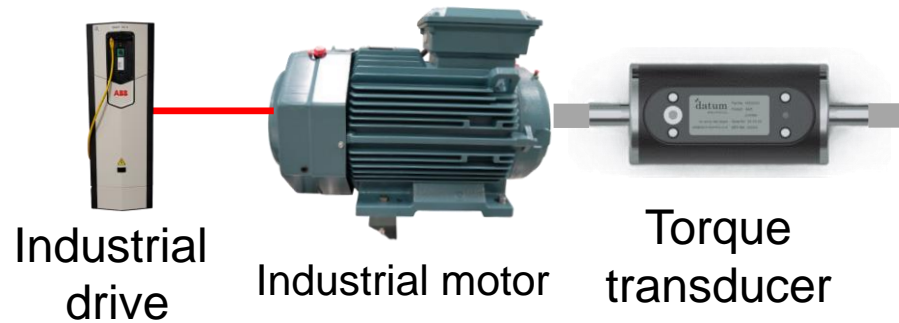
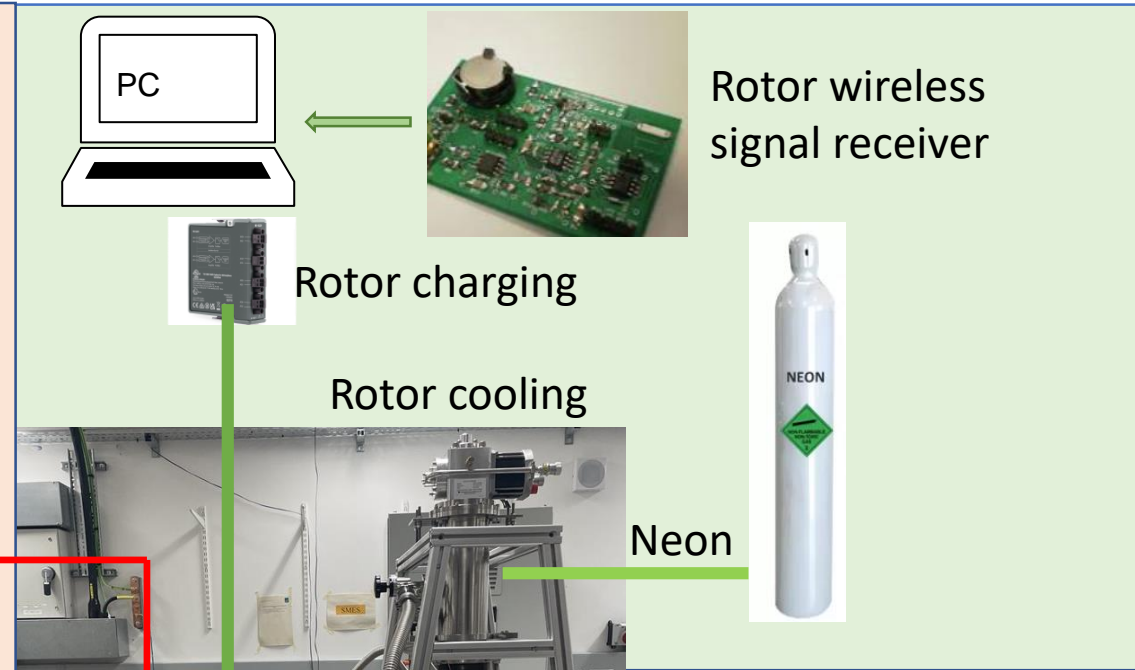
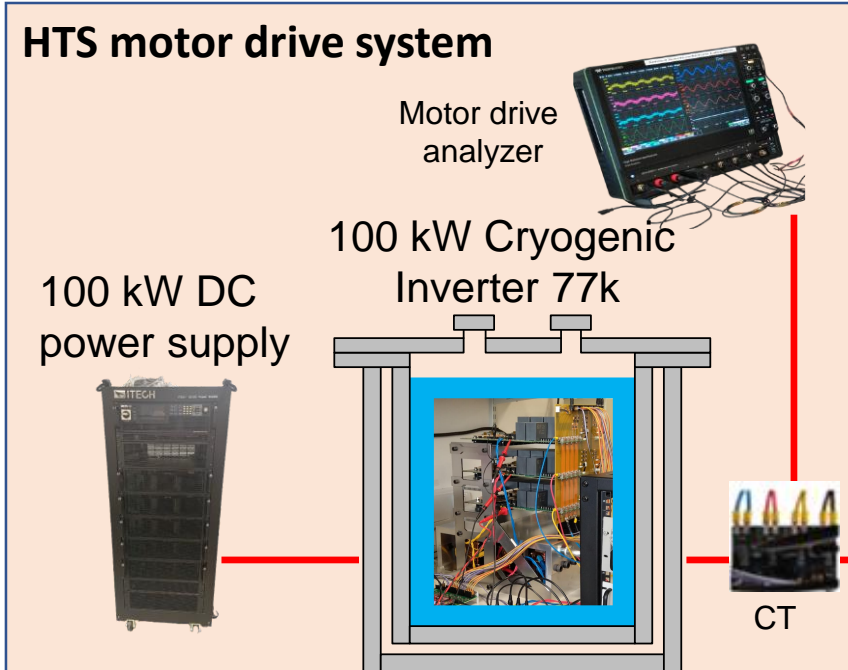

100 kW Cryogenic Propulsion Unit Platform

Thank you for listening Questions?

We are looking for visiting researchers and PhD students to work on the following topics:

1. Superconducting aviation motor design
2. Condition monitoring and fault prevention



Lab info

Prof Min Zhang, FIET
Min.zhang@strath.ac.uk