



RIKEN Yokohama Campus



*This work is supported by  
the Japan Science and  
Technology Agency (JST)  
under the JST-Mirai Program  
Grant Number JPMJMI17A2.*



## ***Development of a 1.3 GHz (30.5 T) LTS/HTS NMR magnet in the persistent-mode***

***Yoshinori Yanagisawa (RIKEN)***



Y. Yanagisawa, Virtual CCA 2021 - NMR & MRI Session -, NM-1, Oct. 11-15, 2021

1

Thank you for the kind introduction. First of all, I'd like to show my gratitude for the organizing committee of the Virtual CCA 2021, in particular Matsumoto-sensei and Izumi-san, for giving me this special opportunity of an invited talk. Today I am going to talk about the present status of a Japanese project to develop a persistent-mode 1.3 GHz NMR magnet using REBCO CC.

## Collaborators

IEEE CSC & ESAS SUPERCONDUCTIVITY NEWS FORUM (global edition), December 2021.  
Invited presentation NM-1 given at CCA 2021, October 11 – 15, 2021, Virtual.



**RIKEN:** Y. Suetomi, R. Piao, T. Yamazaki



**JASTEC:** M. Yoshikawa, M. Hamada, K. Saito



**NIMS:** Y. Takeda, N. Banno, K. Inoue, Y. Takano, G. Nishijima, H. Kitaguchi



**Sumitomo Electric:** K. Ohki, T. Yamaguchi, T. Nagaishi, S. Kobayashi



**Aoyama Gakuin University:** U. Nakai, J. Shimoyama



**Okayama University:** H. Ueda



**JEOL REONANCE:** K. Hachitani



**Tokyo Institute of Technology:** Y. Ishii



**JST/RIKEN:** H. Maeda



**Sophia University:** T. Takao, T. Yagai

*And many others*

This work is being carried out with a number of collaborators from various institutions, both academia and industry. Here I'd like to show some of them and to thank everyone, including others who cannot be listed here.



## Development of a persistent-mode 1.3 GHz (30.5 T) NMR magnet in the JST-Mirai Program (FY2017-2026)



- DC superconducting feeder cables for railway systems

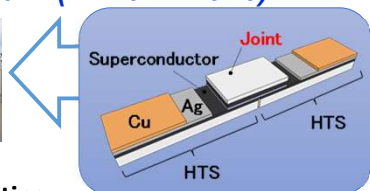

- Joining technology for HTS



- 1.3 GHz (30.5 T) NMR magnet in the persistent-mode with superconducting joints
- NMR measurements with significant impacts

- Analysis of amyloid beta protein related to Alzheimer's disease  
<https://doi.org/10.1021/jacs.1c03346>  
A. Wickramasinghe et al., *J. Am. Chem. Soc.* 2021, **143**, 30, 11462–11472
- Breakthroughs in materials science
- Analysis of natural products
- New drug development

Stage 1: FY2017-2020	Research and development for the basic design of the magnet
Stage 2: FY2021-2024	Detailed magnet design and construction
Stage 3: FY2025-2026	NMR measurements

Y. Yanagisawa, Virtual CCA 2021 - NMR & MRI Session -, NM-1, Oct. 11-15, 2021

3

In the late 2017, we started a project funded by the JST-Mirai Program, in which we develop joining technology for HTS and with this technology we will demonstrate DC superconducting feeder cable operations for railway systems and the persistent-mode operation of a 1.3 GHz (30.5 T) NMR magnet. The 1.3 GHz NMR magnet will be used for various NMR measurements such as analysis of amyloid beta protein related to Alzheimer's disease. Here you see the development schedule, comprising three stages. After the last three years of the R&D phase to make the basic design of the magnet, now we are in the first year of the second stage for the detailed magnet design and construction. In this presentation, I will talk about the technical issues of the magnet focusing on the REBCO CC innermost coil.

## Basic design of the 1.3 GHz (30.5 T) NMR magnet

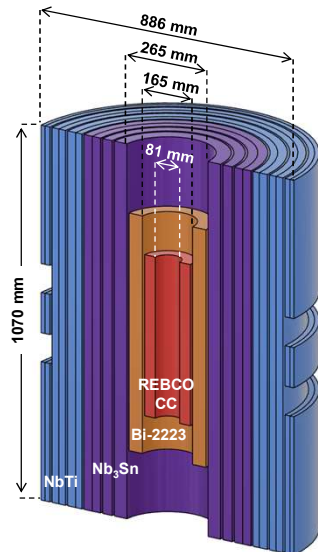

### 30.5 T series-connected LTS/HTS coils in the persistent-mode for high-resolution NMR

Operating temperature (K)	4.2 (LHe)	
Operating current (A)	231	
Self-inductance (H)	988	
Stored energy (MJ)	26.4	
Weight of superconductors (ton)	3.9	
Radial distance of 5 G line (m)	9.9	
HTS inner coils	Layer-winding	REBO / Bi-2223
Overall current density (A/mm <sup>2</sup> )	REBCO / Bi-2223	205 / 137
Field contribution (T)	HTS (REBCO+Bi-2223)	15.7 (8.7+7.0)
	LTS	15.1
Conductor length for winding (km)	REBCO / Bi-2223 / LTS	5.2 / 11.0 / 154
Number of joints	RR / BB	
	RL / BL	
		several / several

Y. Yanagisawa, Virtual CCA 2021 - NMR & MRI Session -, NM-1, Oct. 11-15, 2021

4

Here you can see the basic design of the 1.3 GHz NMR magnet. It is a 30.5 T series-connected LTS/HTS coils in the persistent-mode for high-resolution NMR measurements. The design employs a Bi-2223 coil for the middle part and also uses REBCO innermost coil with a higher current density that benefits the magnet design. The coils are cooled with liquid helium at 4.2 K. The operating current is 231 A and the self-inductance is close to a thousand H. The HTS inner coils generates about a half of the total magnetic field, in which the REBCO coil contributes 8.7 T. For the persistent-mode operation, the magnet requires a lot of joints for HTS, which is a notable feature of the magnet.

## **Technical issues regarding the REBCO CC coil**

- **Persistent-mode operation with HTS joints**
  - *Superconducting joints between HTS*
    - *REBCO/REBCO(RR joint) and Bi-2223/Bi-2223(BB joint)*
  - *Low resistance joints between HTS and LTS*
    - *REBCO/LTS(RL joint) and Bi-2223/LTS(BL joint)*
- **Mechanical stress management**
  - *Mechanical reinforcement for high hoop stress of the REBCO coil*
- **Screening current**
  - *Simulation for screening current-induced field of HTS inner coils*
  - *Consideration of the effect on mechanical stress*
- **Protection**
  - *Protecting the REBCO inner coil from over heating and over stress*

Here I would like to describe technical issues to be addressed for the magnet. For the persistent-mode operation, the magnet requires superconducting joints between HTS, REBCO/REBCO joints and BSCCO/BSCCO joints, and also low resistance joints between HTS and LTS. For the mechanical stress management, we have to consider reinforcement for high hoop stress under the effect of screening current. From the viewpoint of field stability and homogeneity, numerical simulation for screening current-induced field of HTS inner coils are indispensable. For magnet protection, the most important issue is protecting the REBCO coil from over heating and over stress. In this presentation, I will talk about these technical issues and start with the first topic.

## Main coil circuit in the persistent-mode

Conceptual diagram  
of the main coil circuit

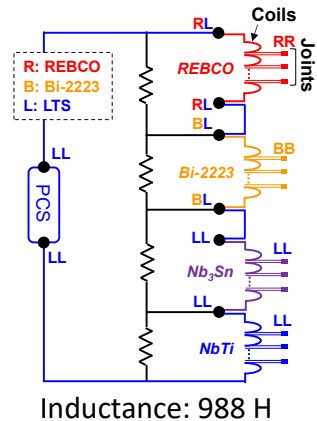

Target field drift rate: <0.01 ppm/h

$$R_{\text{circuit}} < L/\tau = 988/(1/2.78e-12) = 2.75 \times 10^{-9} \Omega$$

Joint	Type	Number of joints	Resistance per joint	Total resistance
RR	Superconducting	17	<10 <sup>-12</sup> Ω	<17 x 10 <sup>-12</sup> Ω
BB	Superconducting	<45	<10 <sup>-12</sup> Ω	<45 x 10 <sup>-12</sup> Ω
RL	Low resistance	Several*	<10 <sup>-10</sup> Ω	<2 x 10 <sup>-10</sup> Ω
BL	Low resistance	Several*	<10 <sup>-10</sup> Ω	<6 x 10 <sup>-10</sup> Ω
LL	Superconducting	~50	<10 <sup>-12</sup> Ω	<50 x 10 <sup>-12</sup> Ω
Coil (conductor)				Total resistance
REBCO				<10 <sup>-10</sup> Ω
Bi-2223				<10 <sup>-10</sup> Ω
LTS				<10 <sup>-11</sup> Ω

$$R_{\text{circuit}} < 1.2 \times 10^{-9} \Omega$$

\*Depending on protection circuit design

I am going to talk about the main coil circuit in the persistent-mode. Here we have a conceptual diagram of the main coil circuit with series-connected coils having a self-inductance of 988 H. As an NMR magnet, target field drift rate is 0.01 ppm/h and the permissible circuit resistance is 2.7 nOhm. Here you can see breakdown of the circuit resistance including joints and coil conductors. For joints with HTS, each RR and BB joint requires 10<sup>-12</sup> Ohm of superconducting joint since number of joints are large, while each RL and BL joint can be accepted with 10<sup>-10</sup> Ohm low resistance as the joint numbers are small.

# Loading condition for HTS joints

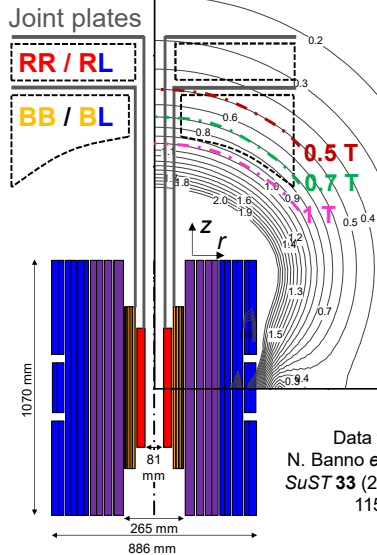

Data from N. Banno *et al.*, SuST 33 (2020) 115015

IEEE CSC & ESAS SUPERCONDUCTIVITY NEWS FORUM (global edition), December 2021.  
Invited presentation NM-1 given at CCA 2021, October 11 – 15, 2021, Virtual.

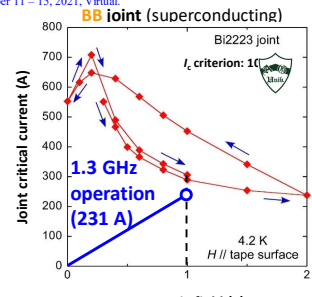
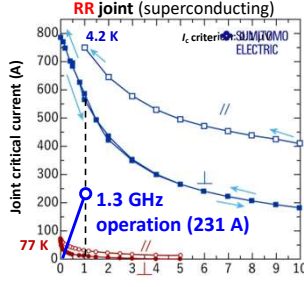

Joints are feasible for the use at the 1.3 GHz operation.

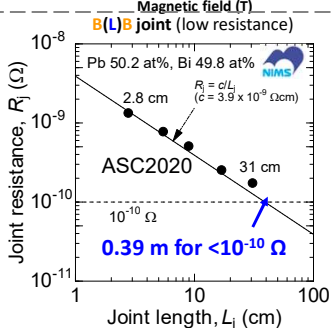
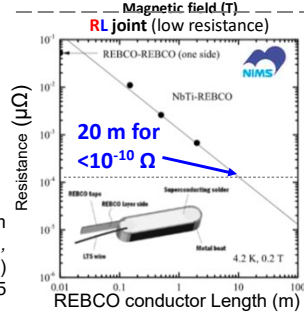

Here I am going to focus on loading conditions for HTS joints. They are installed on the joint plates located over the layer-wound main coils, where the magnetic field is lower than 1 T to secure joint performance. If you look at these graphs you can see performances of the joints for the operating condition. I would like to emphasize that they are feasible for the use at the 1.3 GHz operation although improvement on joint process is still required.

## Verifications for persistent-mode NMR magnets with superconducting joints between HTSs

### 400 MHz (9.39 T) LTS/REBCO NMR magnet

IGS RR joints by SEI

K. Ohki *et al.*, *SuST* **30** (2017) 115017  
 T. Kato *et al.*, *SuST* **33** (2020) 105008

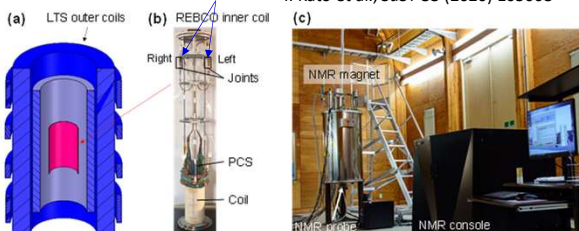

Magnetic field drift for TWO YEARS

Corresponding resistance  $< 10^{-14} \Omega$

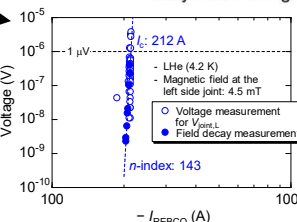
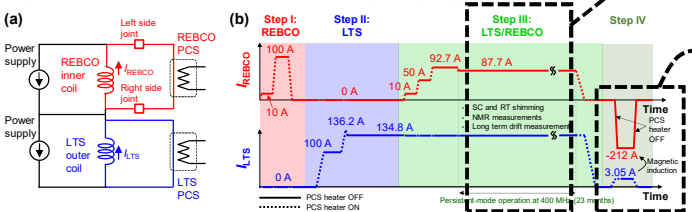
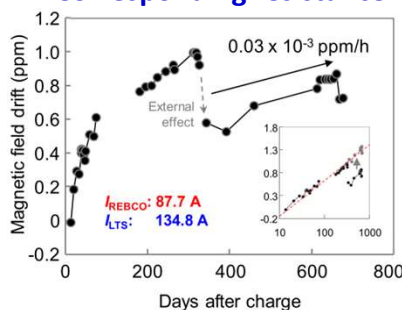

Excellent superconducting V-I performance of a joint

With superconducting joints between HTS, we have been making verifications for persistent-mode NMR magnets. This is a 400 MHz LTS/REBCO NMR magnet using a small REBCO inner coil terminated with superconducting REBCO-REBCO joints, developed by Sumitomo Electric, having excellent superconducting V-I performance; Dr Nagaishi will focus on this joint technology later in his talk. We operated this magnet in the persistent-mode for two years. As you can see, the magnetic field drift is extremely small and estimated resistance is lower than  $10^{-14} \Omega$ , which indicates the joints functioned perfectly in the high-resolution NMR system.



## Verifications for persistent-mode NMR magnets with superconducting joints between HTSs

**400 MHz (9.39 T) LTS/Bi-2223 NMR magnet under development**

Y. Takeda et al 2019 Appl. Phys. Express 12 023003

**Superconducting joint between Bi-2223 conductors**



Lead conductors are terminated with the joint technology and the joints are installed on the joint plate.

- Type HT-NX
- ID/OD/height: 99.7 / 105.3 / 345 mm
- 76 turns x 8 layers
- Conductor length: 196 m
- B0: 2.1 mT/A

**Bi-2223 inner coil**



**400 MHz LTS/Bi-2223 NMR magnet**

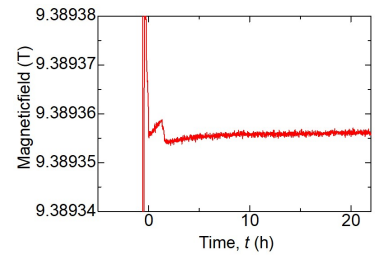

We have been making a similar magnet test with superconducting joints for high-strength Bi-2223 conductors. Though I'm not going into detail, the magnet is in operation as a 400 MHz magnet.

## **Technical issues regarding the REBCO CC coil**

- **Persistent-mode operation with HTS joints**
  - *Superconducting joints between HTS*
    - *REBCO/REBCO(RR joint) and Bi-2223/Bi-2223(BB joint)*
  - *Low resistance joints between HTS and LTS*
    - *REBCO/LTS(RL joint) and Bi-2223/LTS(BL joint)*
- **Mechanical stress management**
  - *Mechanical reinforcement for high hoop stress of the REBCO coil*
- **Screening current**
  - *Simulation for screening current-induced field of HTS inner coils*
  - *Consideration of the effect on mechanical stress*
- **Protection**
  - *Protecting the REBCO inner coil from over heating and over stress*

I would like to move on to mechanical stress management on the REBCO coil.

## Mechanical reinforcement for high hoop stress of the REBCO inner coil

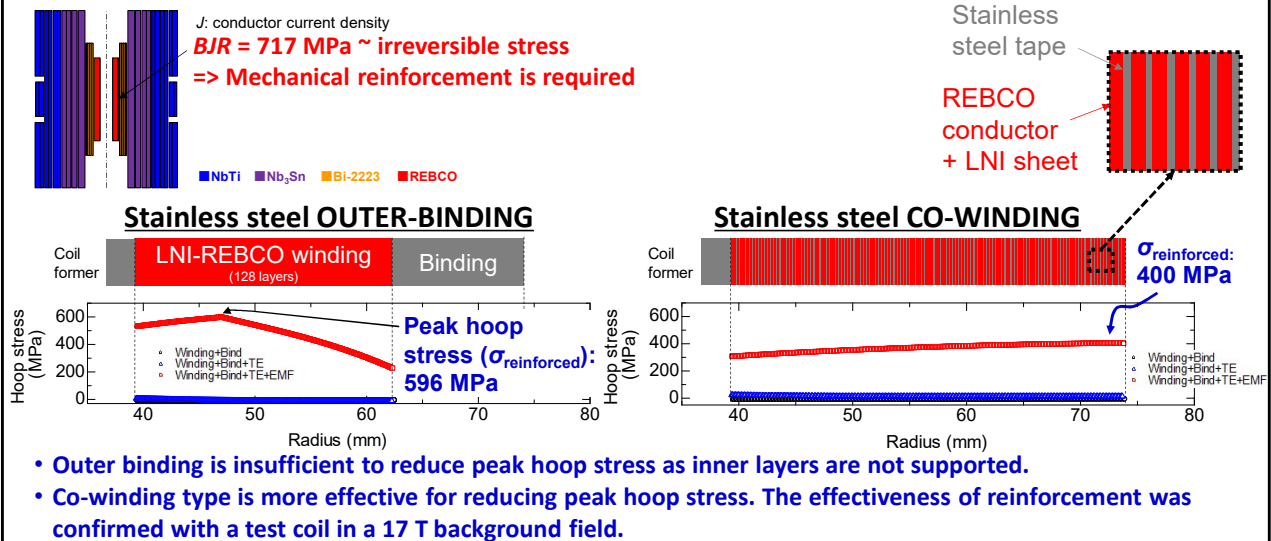

Y. Yanagisawa, Virtual CCA 2021 - NMR & MRI Session -, NM-1, Oct. 11-15, 2021

11

Although the CC is mechanically strong, we have to consider reinforcement for the REBCO inner coil. For a reasonably compact magnet, the winding current density of the REBCO coil has to be about 200 A/mm<sup>2</sup>. Simple BJR calculation gives a hoop stress higher than 700 MPa and the coil requires reinforcement. We made structural analysis on stainless steel outer-binding and co-winding. As you can see, outer-binding reduces the peak hoop stress to 596 MPa, which is still too high. This is because inner layers can not be supported by the outer binding since there are soft polymer materials inside LNI-winding. On the other hand co-winding supports every layer and the peak hoop stress is reduced to as low as 400 MPa. We have confirmed the effectiveness of the reinforcement through a coil test in a background field.

## **Technical issues regarding the REBCO CC coil**

- **Persistent-mode operation with HTS joints**
  - *Superconducting joints between HTS*
    - *REBCO/REBCO(RR joint) and Bi-2223/Bi-2223(BB joint)*
  - *Low resistance joints between HTS and LTS*
    - *REBCO/LTS(RL joint) and Bi-2223/LTS(BL joint)*
- **Mechanical stress management**
  - *Mechanical reinforcement for high hoop stress of the REBCO coil*
- **Screening current**
  - *Simulation for screening current-induced field of HTS inner coils*
  - *Consideration of the effect on mechanical stress*
- **Protection**
  - *Protecting the REBCO inner coil from over heating and over stress*

I am going into field stability and homogeneity.

## Simulation for screening current-induced field

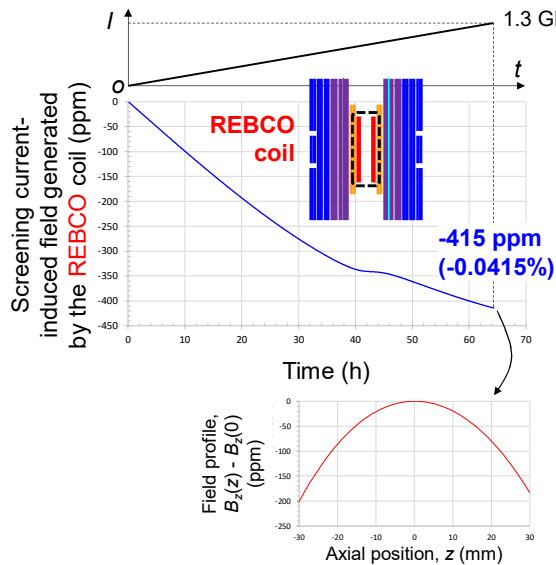

The simulation was made by Prof. Ueda of Okayama University

- The screening current-induced field is sufficiently small and the field drift due to the relaxation of screening currents can be stabilized with field-frequency lock system.
- Z2 harmonic can be compensated with ferromagnetic shimming
- SCIF by the Bi-2223 inner coils will also be simulated.

3D FEM with the fast multipole method  
Ueda et al., *IEEE TAS* **23** (2013) 4100805

It is well known that the screening current affect the stability and homogeneity of the magnetic field, which is vital for NMR spectroscopy. One of the collaborators, Prof. Ueda, of Okayama University, made a numerical simulation for the screening current-induced field of the REBCO innermost coil. The result shows the screening current-induced field is sufficiently small and we believe that the field drift due to the relaxation of the screening currents can be stabilized with field-frequency lock system. In addition, a main field inhomogeneity of Z2 harmonic can be compensated with passive shimming with ferromagnetic materials.

## Simulation for screening current-induced stress (strain)

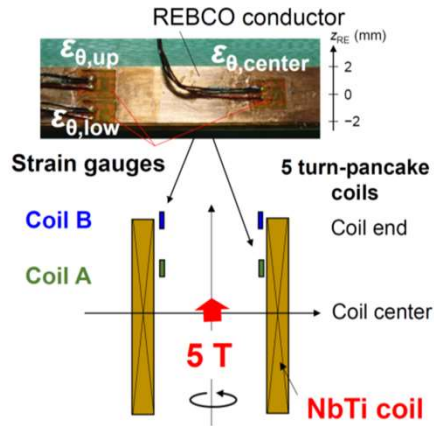

*Simulated results will be published in SuST.*

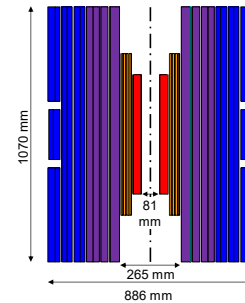

**Simulation for the 1.3 GHz NMR magnet to confirm sufficient stress margin under mechanical reinforcement**



The simulation was made by Prof. Ueda of Okayama University  
Submitted to SuST

The screening current also affects a mechanical stress as well as the magnetic field. Prof Ueda also made numerical calculation on the screening current-induced stress, which can simulate measured stress affected by the screening current. With this simulation method, we will confirm that the REBCO inner coil of our 1.3 GHz magnet has sufficient stress margin under mechanical reinforcement.

## **Technical issues regarding the REBCO CC coil**

- **Persistent-mode operation with HTS joints**
  - *Superconducting joints between HTS*
    - *REBCO/REBCO(RR joint) and Bi-2223/Bi-2223(BB joint)*
  - *Low resistance joints between HTS and LTS*
    - *REBCO/LTS(RL joint) and Bi-2223/LTS(BL joint)*
- **Mechanical stress management**
  - *Mechanical reinforcement for high hoop stress of the REBCO coil*
- **Screening current**
  - *Simulation for screening current-induced field of HTS inner coils*
  - *Consideration of the effect on mechanical stress*
- **Protection**
  - *Protecting the REBCO inner coil from over heating and over stress*

Finally I will talk about protection regarding the REBCO coil.

## Quench protection of a REBCO inner coil

A model magnet for the 1.3 GHz NMR magnet

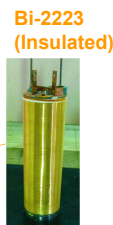
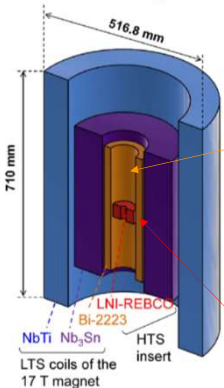

Bi-2223 (Insulated)



LNI-REBCO



REBCO winding

Y Suetomi *et al* 2021 *Supercond. Sci. Technol.* **34** 064003  
<https://doi.org/10.1088/1361-6668/abf54e>

REBCO coil self quench at 31.4 T => No degradation

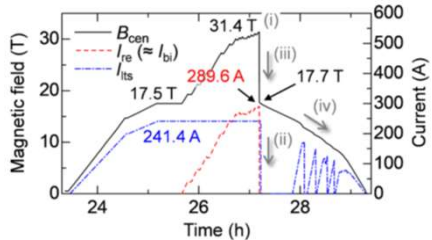

- REBCO coil **survived from self-quench at 31.4 T**, owing to current bypassing over the winding.
- Numerical simulation revealed **contact resistivity inside the LNI winding** plays the key role for protection, which has to be properly controlled.

(a)  $\rho_{ct} = 10,000 \mu\Omega\text{cm}^2$

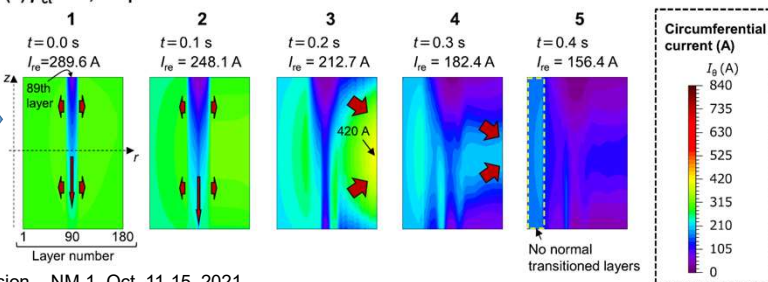

We made charging experiment on a model magnet for the 1.3 GHz NMR magnet as shown by this coil cross-section, having 17 T LTS outsert, a Bi-2223 coil and the REBCO insert wound with the LNI method which give self-protecting characteristics from quench. In the experiment, the REBCO coil quenched at a center field of 31.4 T and it showed no degradation in V-I performance. We made numerical simulation on this quench event and revealed that high contact resistivity inside LNI winding played the key role for protection, which has to be properly controlled.



## Quench protection concept regarding the REBCO inner coil

### Options

	LNI-REBCO	Insulation-REBCO
REBCO coil self-quench	✓	<b>Difficult (due to almost no normal zone propagation)</b>
LTS coil quench	✓	✓
Contact resistivity control	<b>Required =&gt; Should be addressed intensively</b>	<b>Not required</b>

Based on the results, I would like to overview the quench protection concepts regarding the REBCO inner coil. For insulated REBCO coil, we can come to a relatively simple solution, in which the REBCO coil can be protected in the cases of LTS coil quench if we do not consider the case of a self-quench of the REBCO coil. On the other hand, the LNI-method can provide quench protection characteristics from both REBCO coil self-quench and LTS coil quench, we have to control the contact resistivity and to address this issue intensively. Considering the pros and cons we will make a decision.

## Summary

- **1.3 GHz NMR magnet: 30.5 T series-connected LTS/HTS coils in the persistent-mode with superconducting joints for HTS**
- **One of the key issues is to take advantage of the REBCO CC for the innermost coil.**

<b>Stage 1: FY2017-2020</b>	<b>R&amp;D for conceptual design of the magnet</b>
<b>Stage 2: FY2021-2024</b>	<b>Detailed magnet design and construction</b>
<b>Stage 3: FY2025-2026</b>	<b>NMR measurements</b>

I would like to summarize my presentation. Our target is a 1.3 GHz NMR magnet, that is 30.5 T series-connected LTS/HTS coils in the persistent-mode. One of the key issues is to take advantage of the REBCO CC for the innermost coil. We have been making technical development on the magnet to finalize the conceptual design of the magnet.

## Further technical potential of HTS joints

Y Yanagisawa *et al* 2021 *Supercond. Sci. Technol.* **34** 115006  
<https://doi.org/10.1088/1361-6668/ac2120>

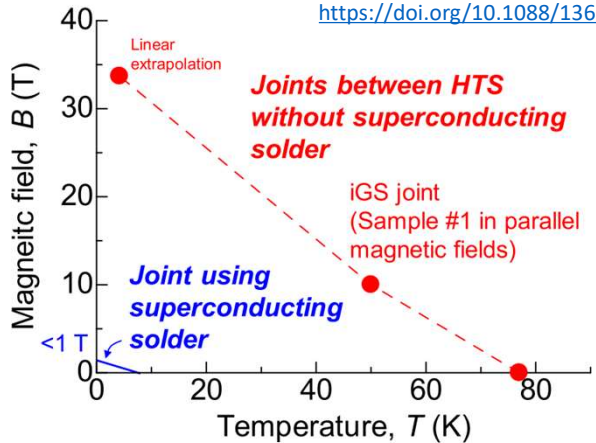

- Lower field (e.g. <1 GHz) compact NMR without liquid helium (which may be driven by cost reduction of CC)
- MRI may also gain similar technical benefit.

Although I talked about an ultra-high field NMR magnet, in the final slide of my presentation, I would like to mention further technical potential of HTS joints. Here you can see magnetic field-temperature plane, showing the available area of LTS joints and that of HTS joints. As is the case of conductor itself, HTS joints can be used in a much wider B-T plane. This notable performance can provide lower field compact NMR without liquid helium, which may be driven by cost reduction of CC. MRI may also gain similar benefit.