



Simplified high-field **stellarator magnets** based on laser patterned wide HTS conductors

victor.prost@renfusion.eu | Magnet Technology 29, Boston, US | July 2025



Renaissance Fusion develops a **simplified HTS stellarator** with plasma-facing liquid walls, and of low aspect ratio

PROBLEMS

Low-field tokamak and stellarator reactors are **large and expensive.**



D-T fusion neutrons induce **radioactivity** and damage to solid parts.



Stellarator coils have **complex** 3D shapes.



SOLUTIONS

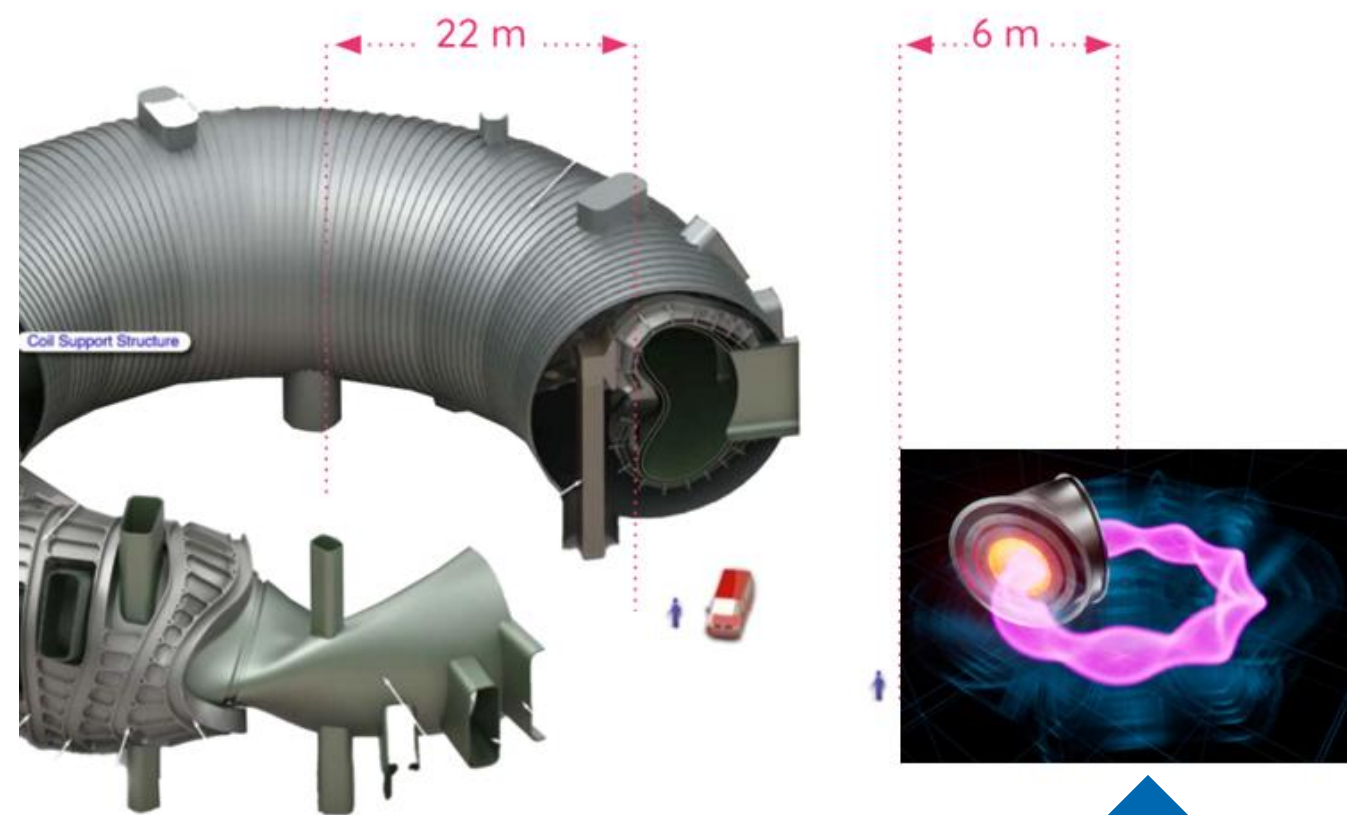

Wide High Temperature Superconductors

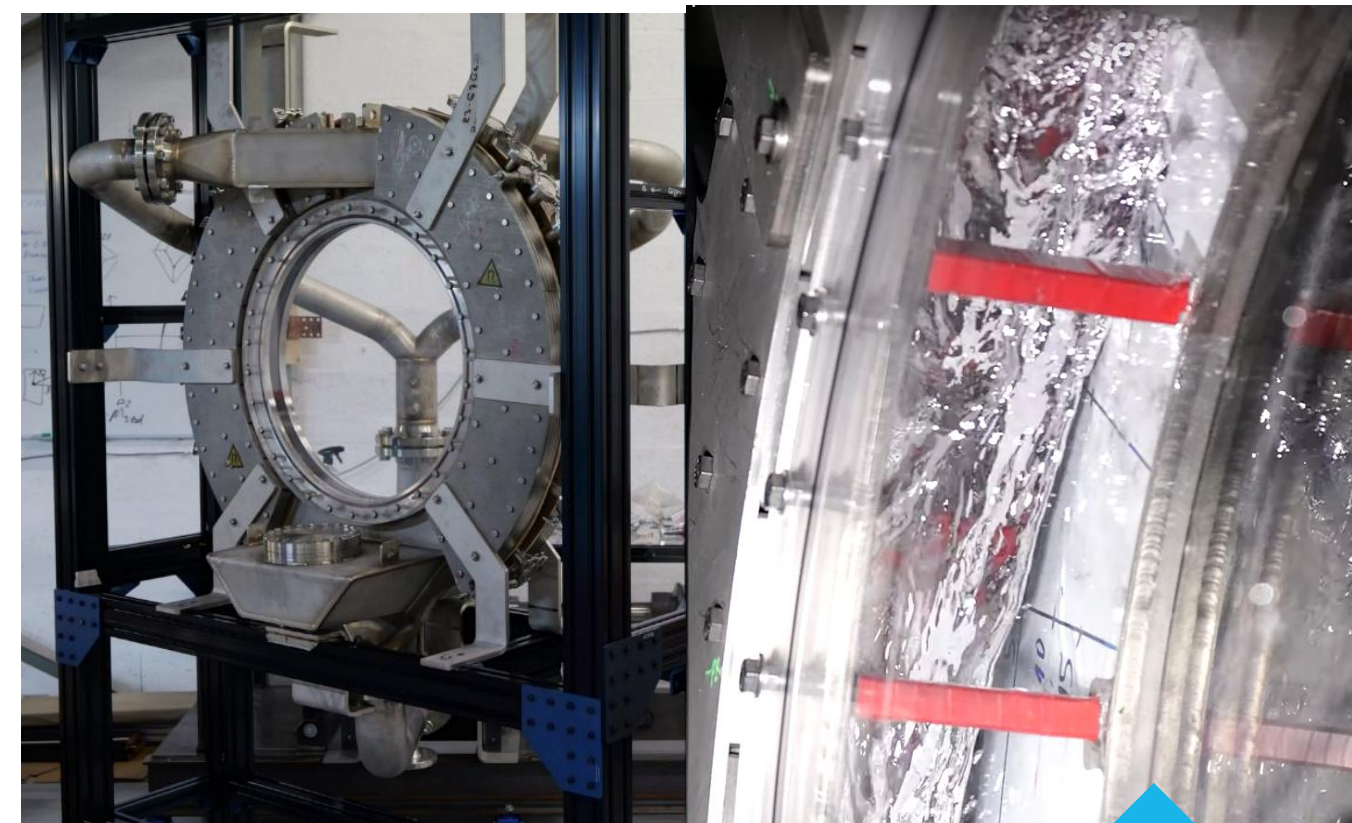

Liquid Metals

Thick flowing first wall for neutron shielding, tritium breeding and heat extraction

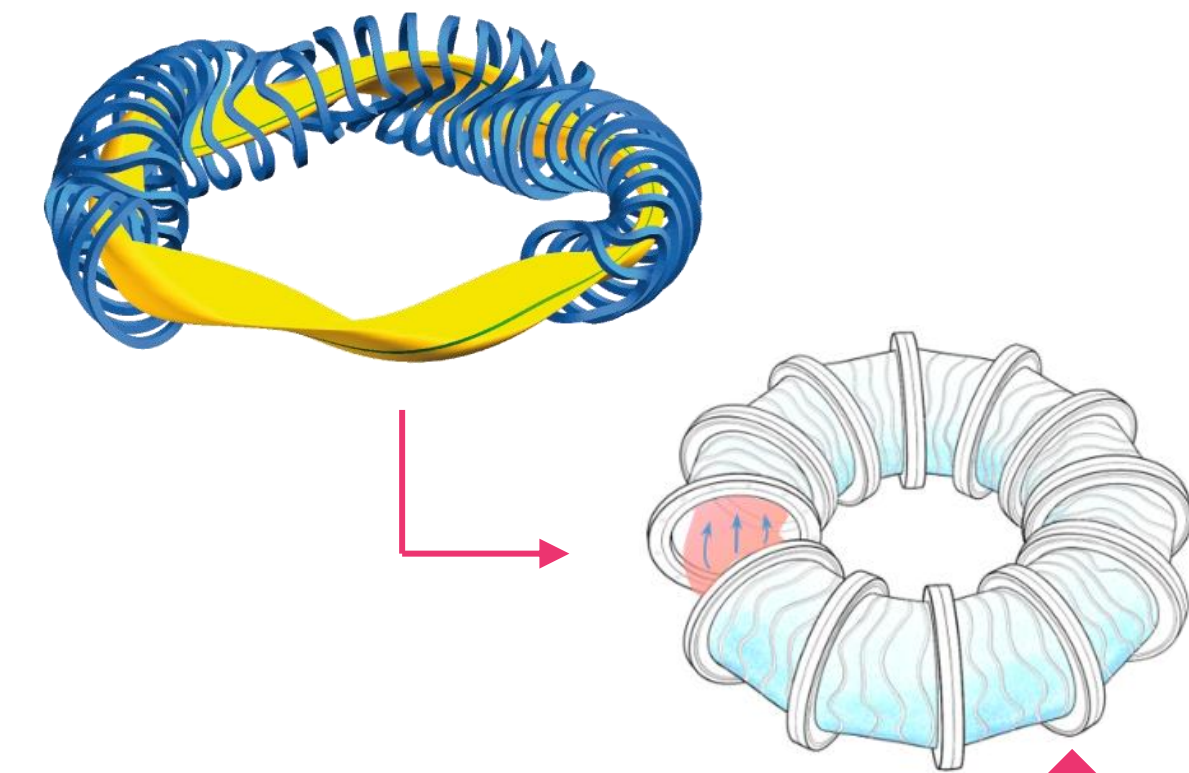

Simplified Stellarators

Cylindrical "coil winding surfaces" wide HTS deposition & laser engraving.



A new approach for stellarator magnets

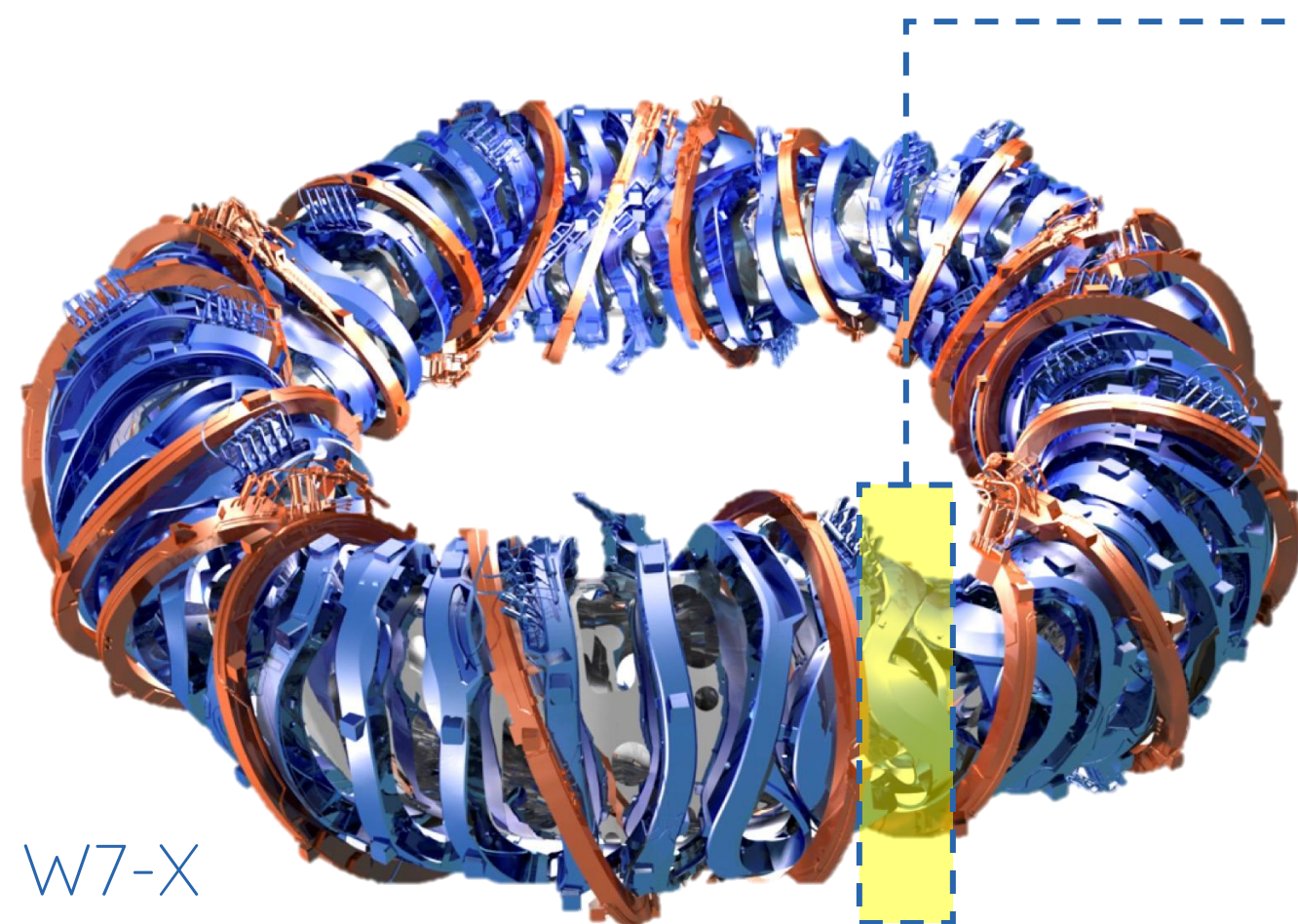

W7-X stellarator

Manufacturing challenges



Vacuum impregnation treatment



Welding of the coil case

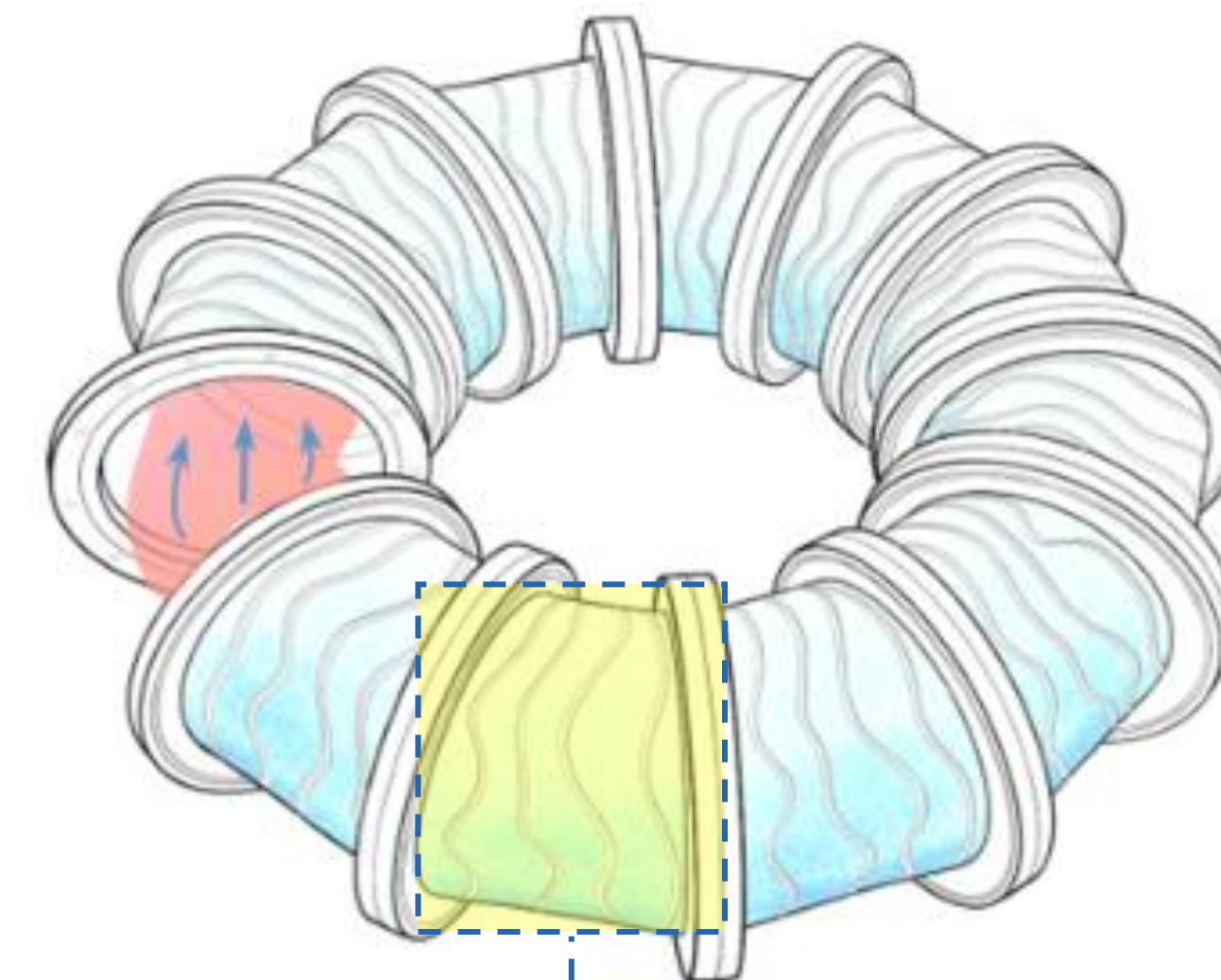

Proposed coil manufacture





4-step program for simplified stellarator magnets

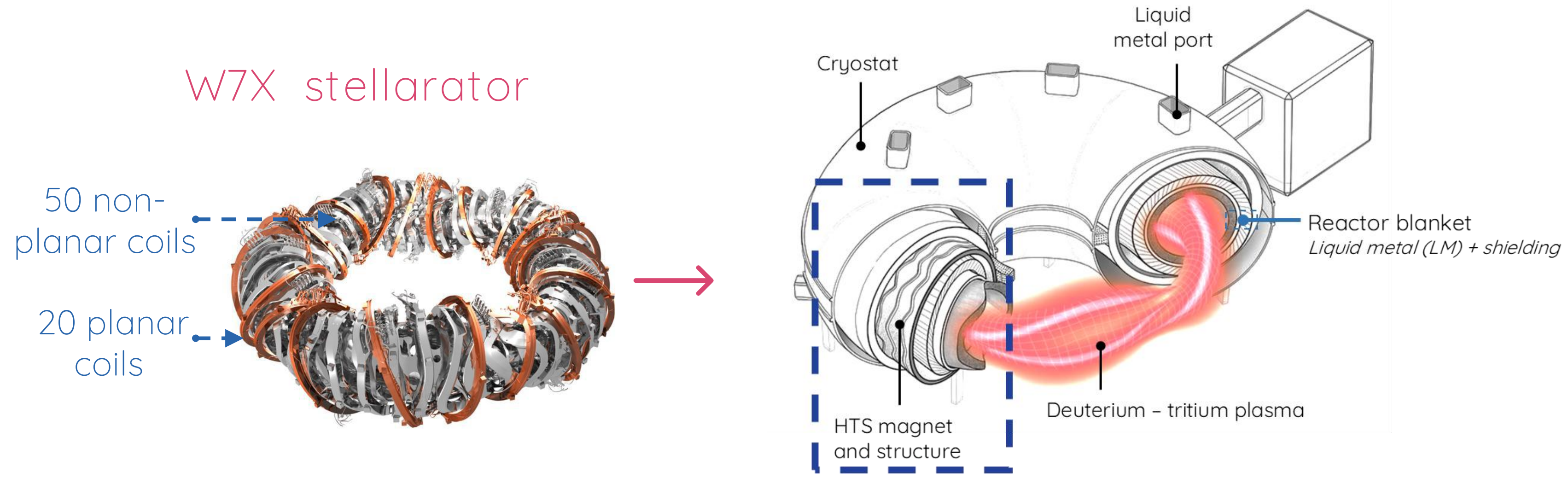

1: Wide HTS manufacturing



2: Laser patterning and winding machine



Laser engraved commercial HTS

3: Grooved magnet technology

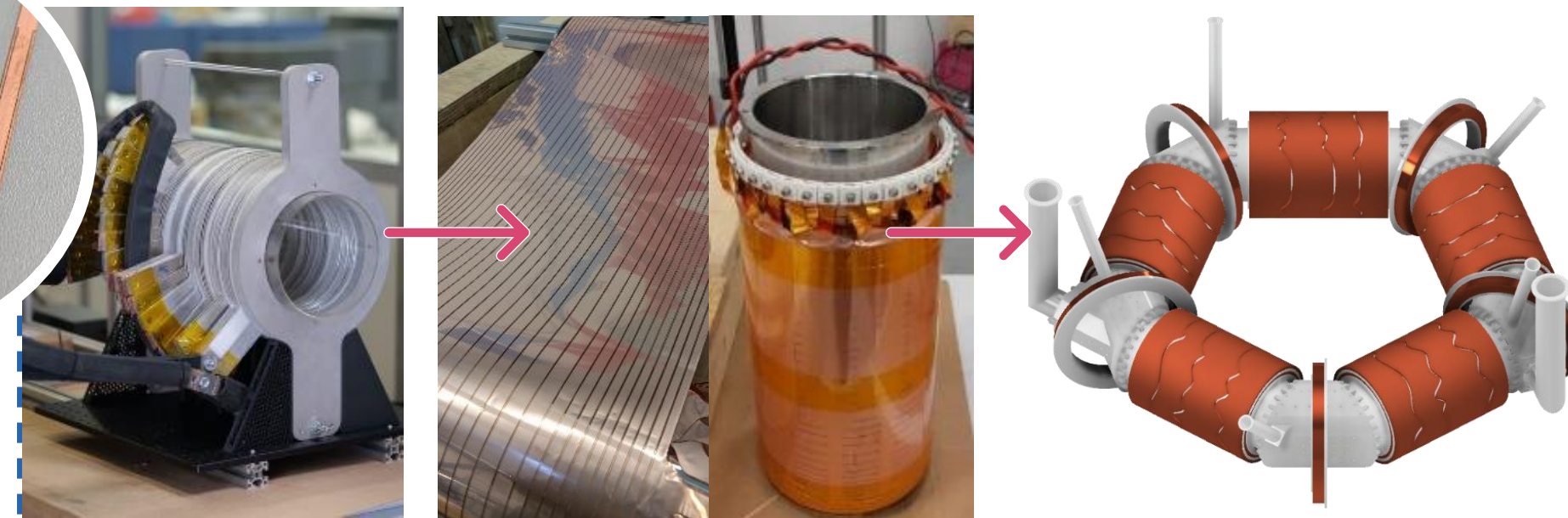

Gyrotron field

MRI field

Stellarator field

4: Robust high-field HTS magnets

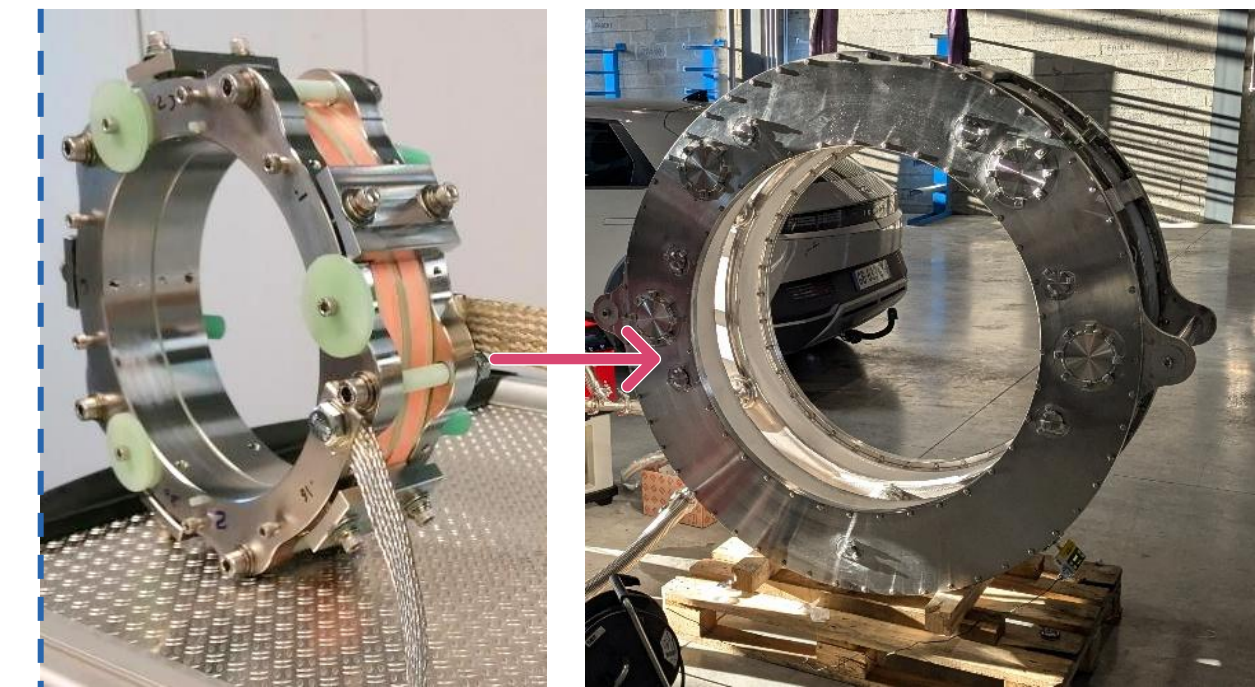

1 T (20 cm)

6 T (1.15 m)



Custom roll to roll laser system completed & commissioned to deliver up to 1m wide engraved conductors

Enabling laser corrugation of HTS wide tapes for stellarator magnets

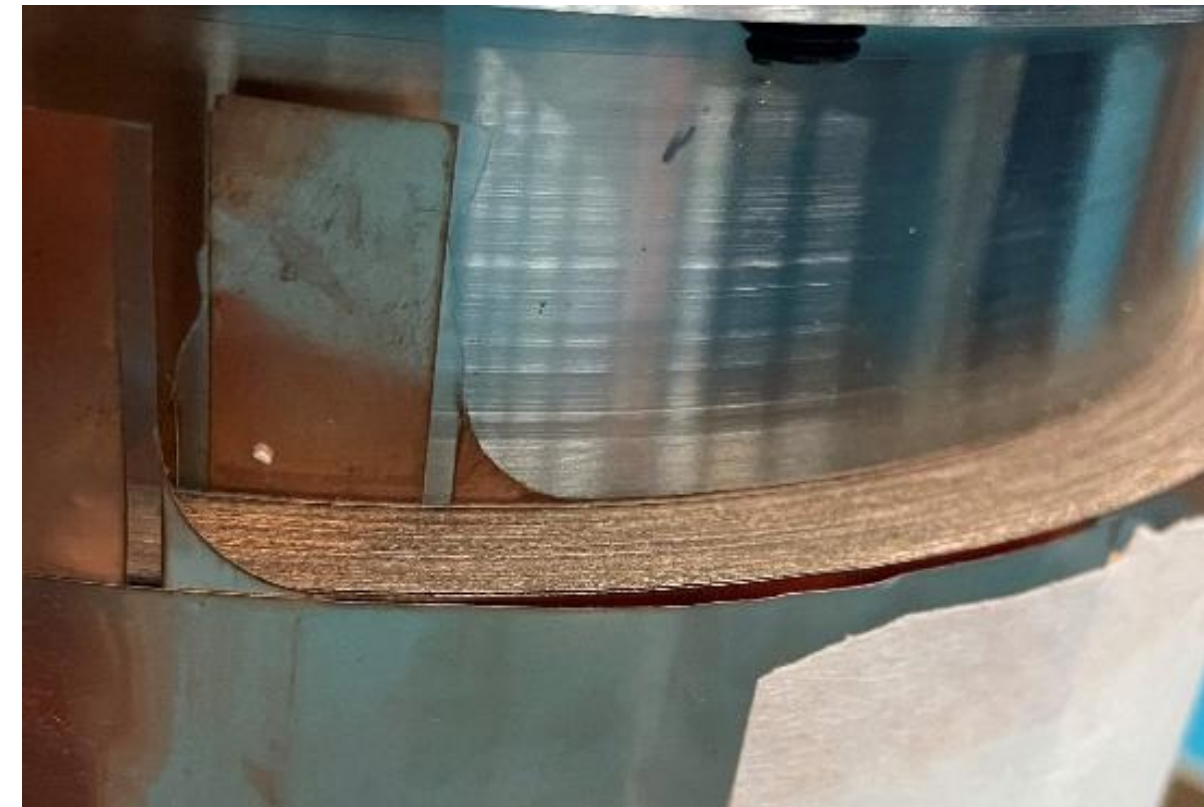
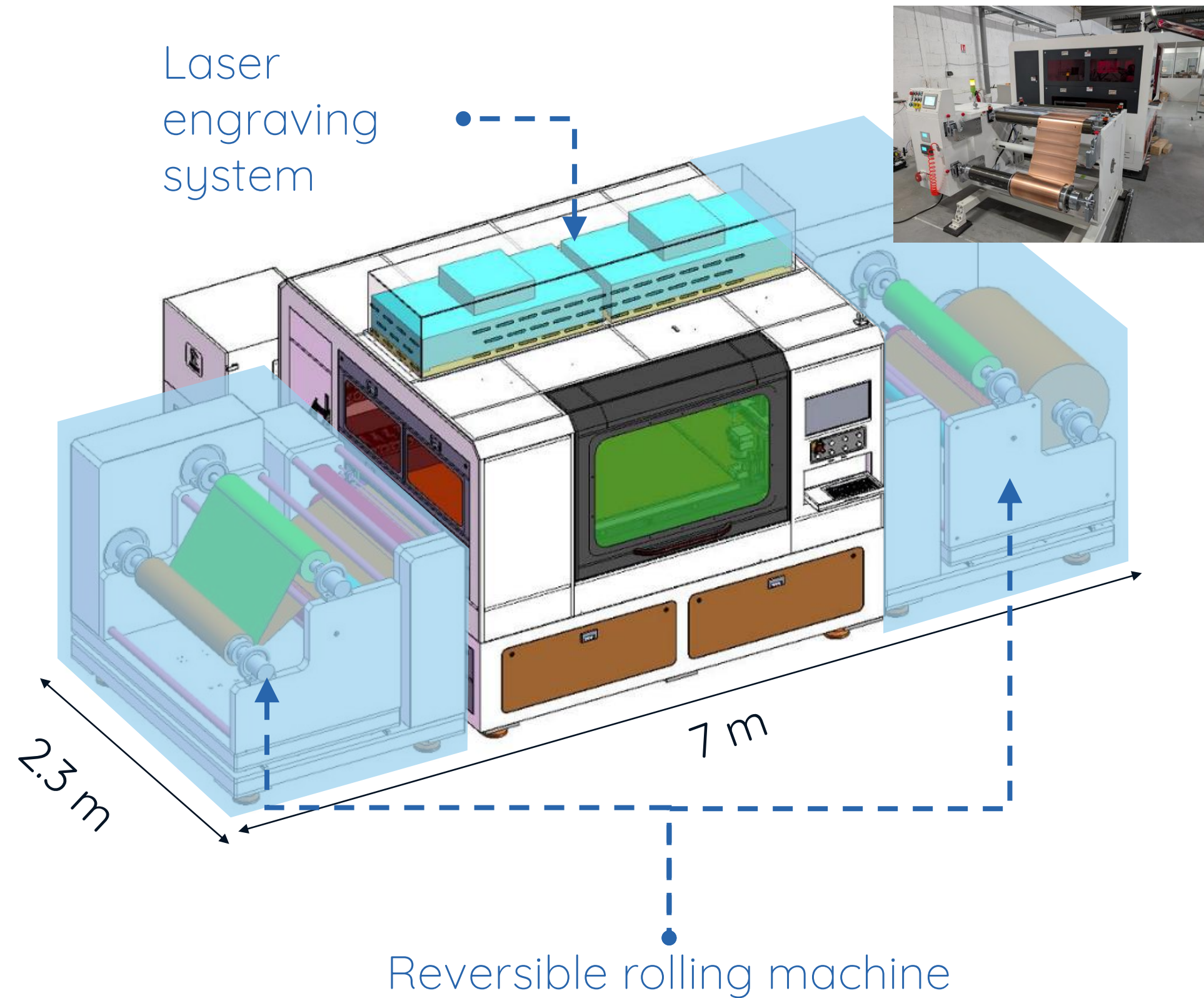

Web guiding within 0.1 mm

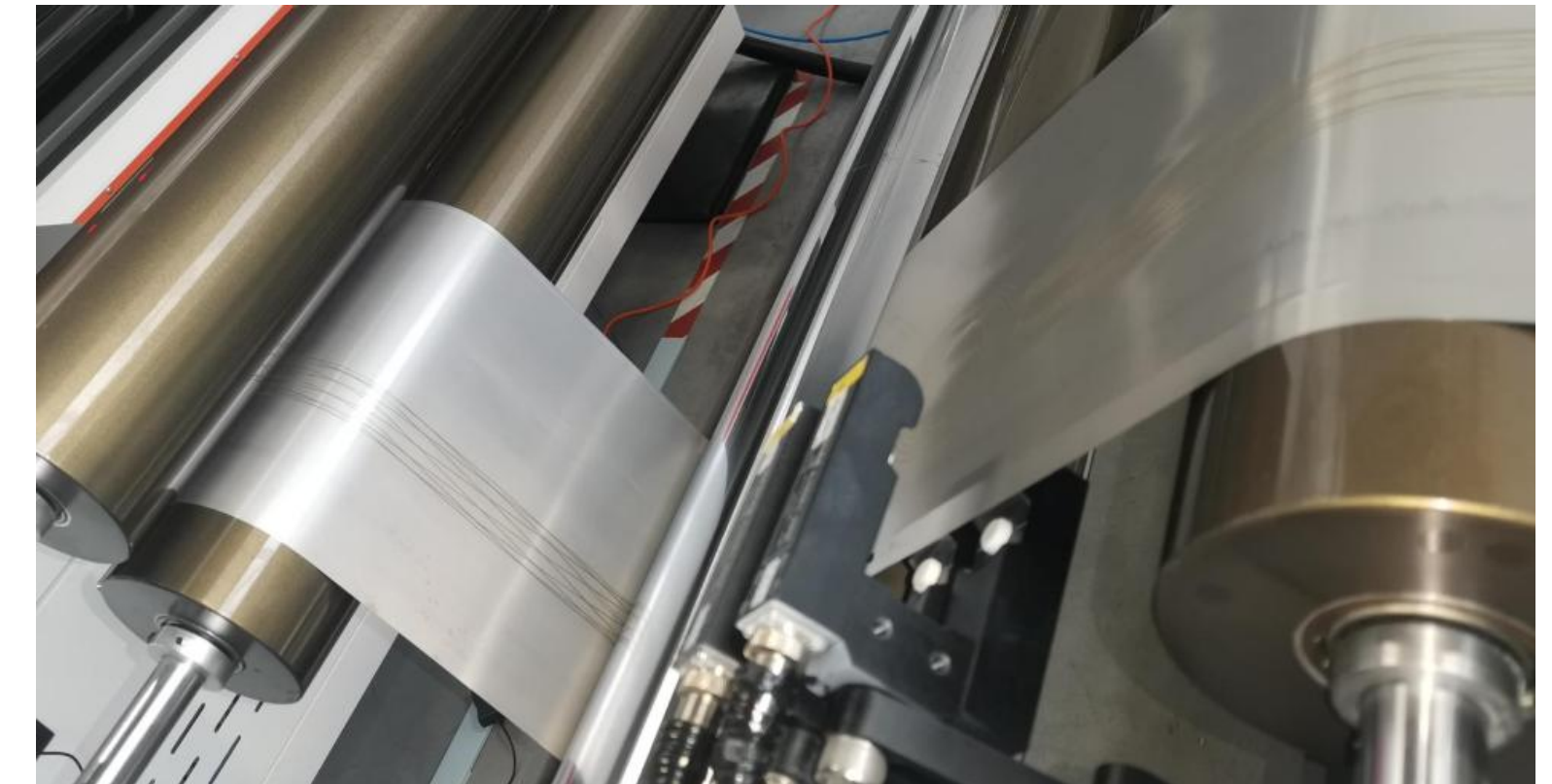

Engraving over meters

Main specs	
Max web speed	230 mm/s
Max web tension	3.2 kN
Web guiding accuracy	0.1 mm
Roll weight capacity	1600 kg
Laser system accuracy	50 μm

→ Dual laser system for engraving and cutting



Ensured engraving of HTS commercial tapes

Engraving caused no apparent laser damage & consistent grooves widths of $60 \pm 10 \mu\text{m}$

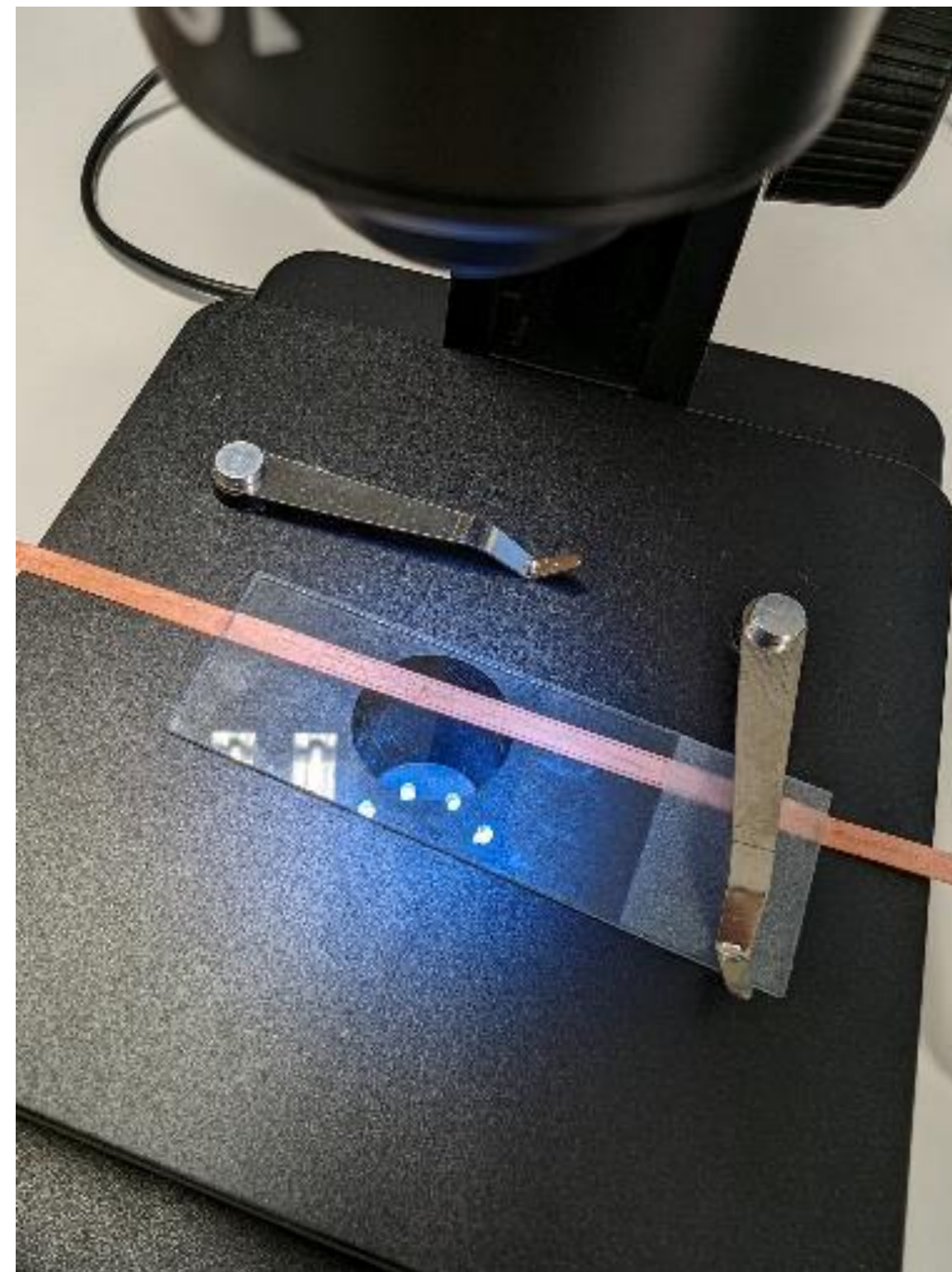
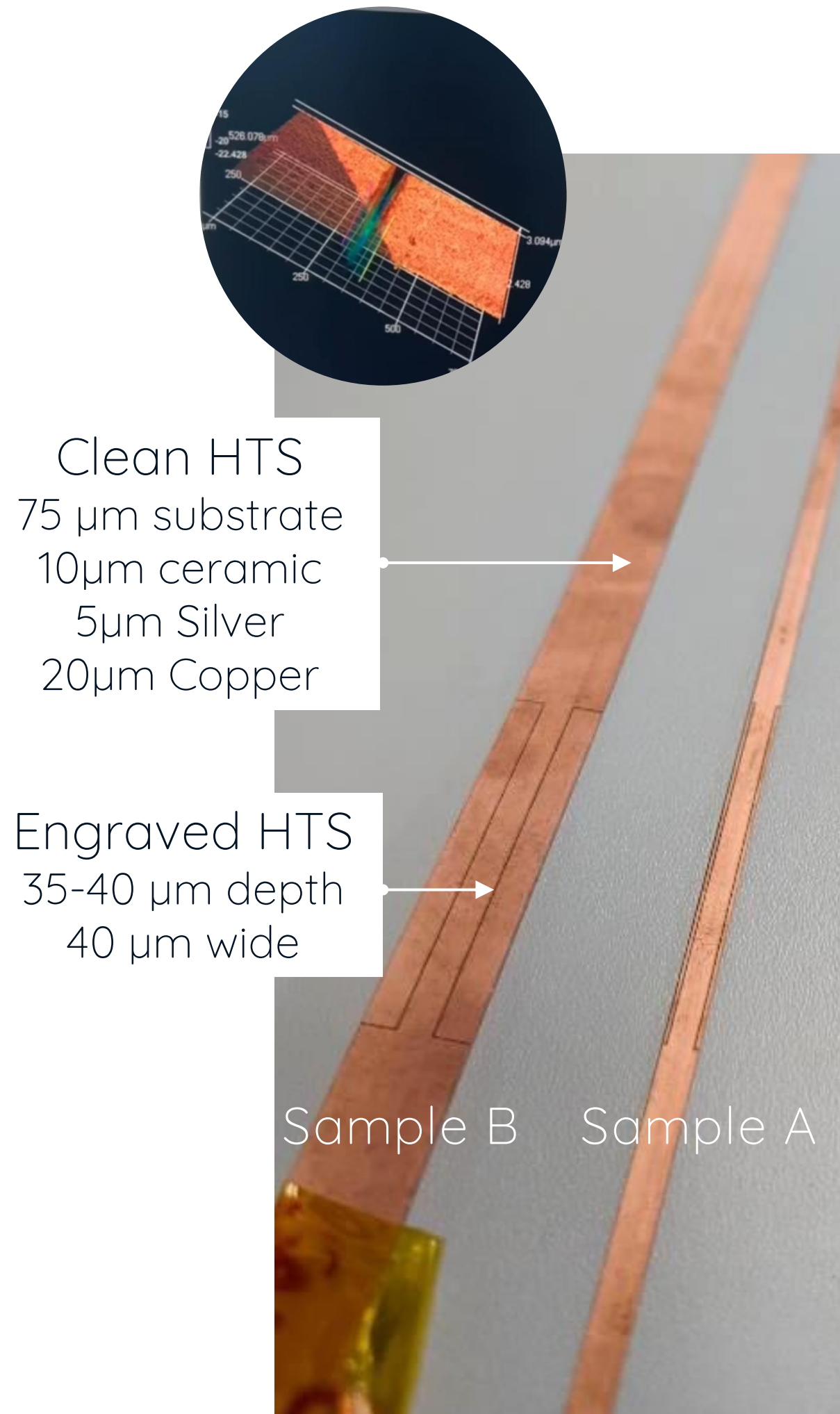

Optical measurements of engraving sizes

	Measured <i>I_c</i> [A/mm]	Manufacturer <i>I_c</i> [A/mm]
Sample A (Sunam)	59 ± 3	62 ± 2
Sample B (Fujikura)	66 ± 2	69 ± 4

LN2 transport current tests



Multi-staged program to increasing field accuracy and complexity to validate engraved magnets approach

Target magnetic field

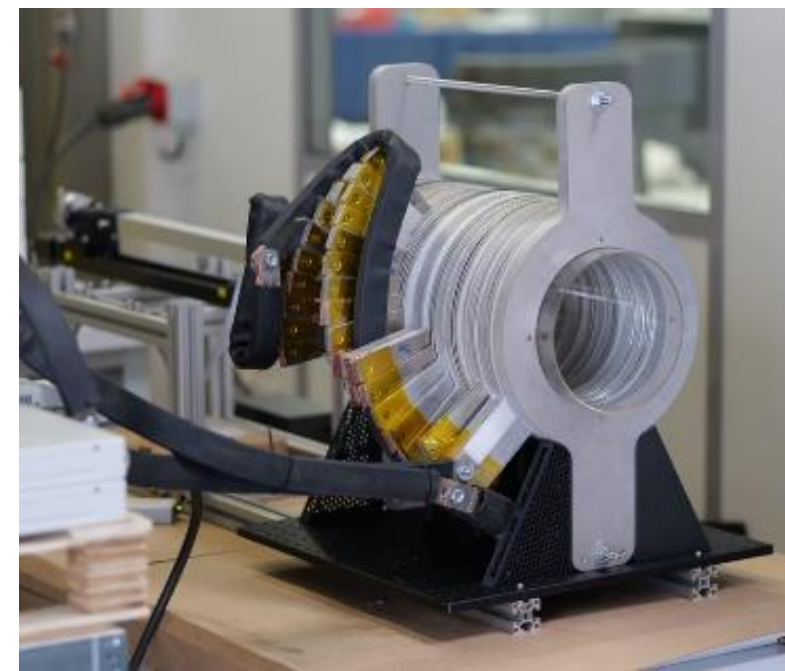
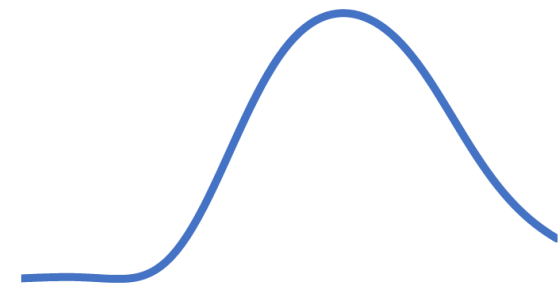

Gyrotrotron field
1D grooves - machined

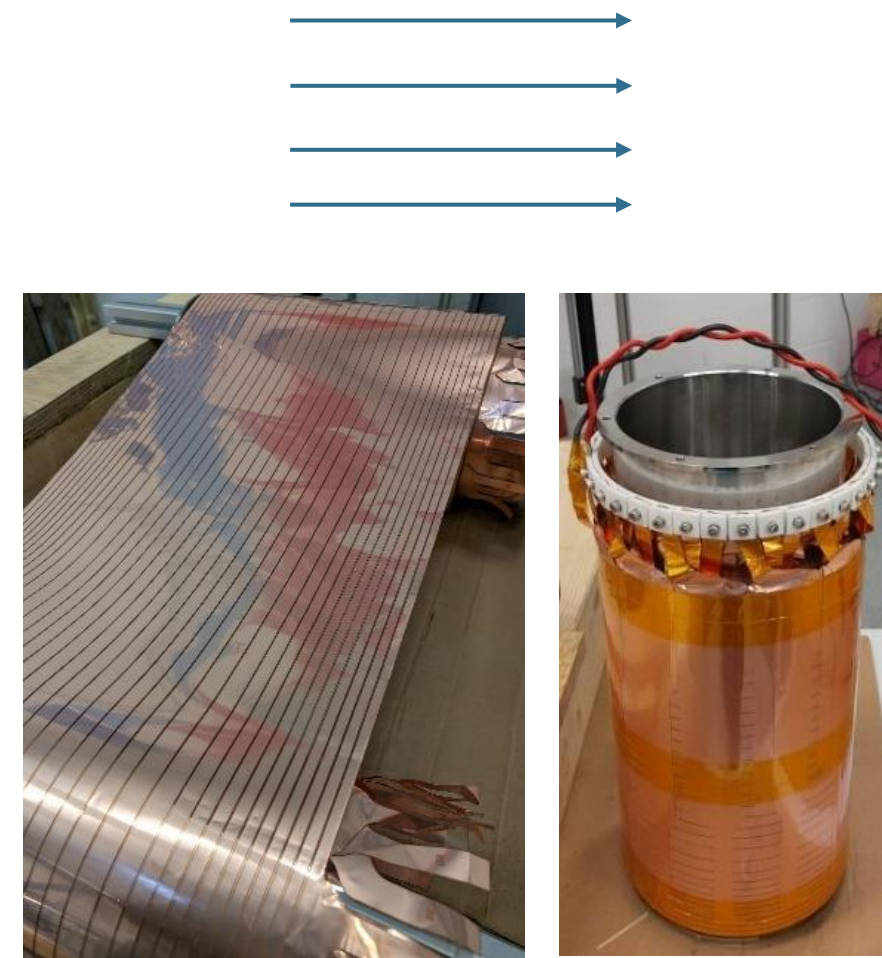

MRI field
1D grooves - laser

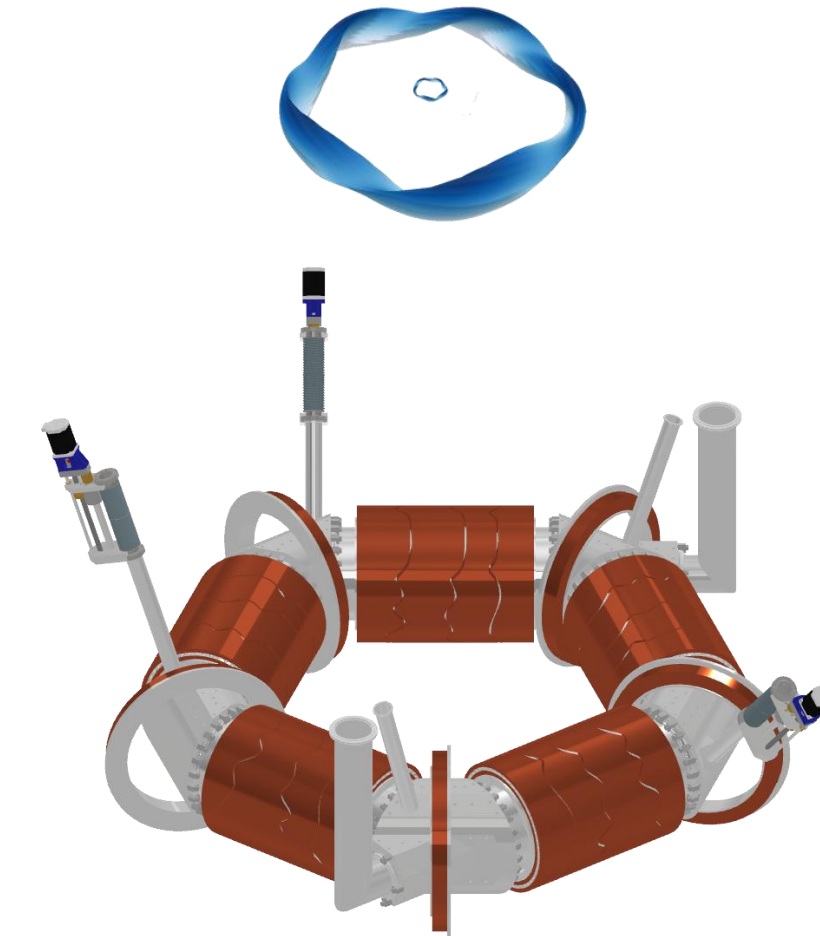

Stellarator field
2D grooves - laser

Concept

Field magnitude	0.02 T	0.1 T	0.1 T
Goal	Error $\leq 10^{-2}$	Error $\leq 10^{-5}$	Closed flux surfaces
Material	Aluminum single layer	Copper multi-layer	Copper multi-layer
Measurement	Hall probe array	NMR	Electron beam



Experimental proof of concept validation of magnet grooving technology with gyrotron field

Inverse problem solver for target magnetic field

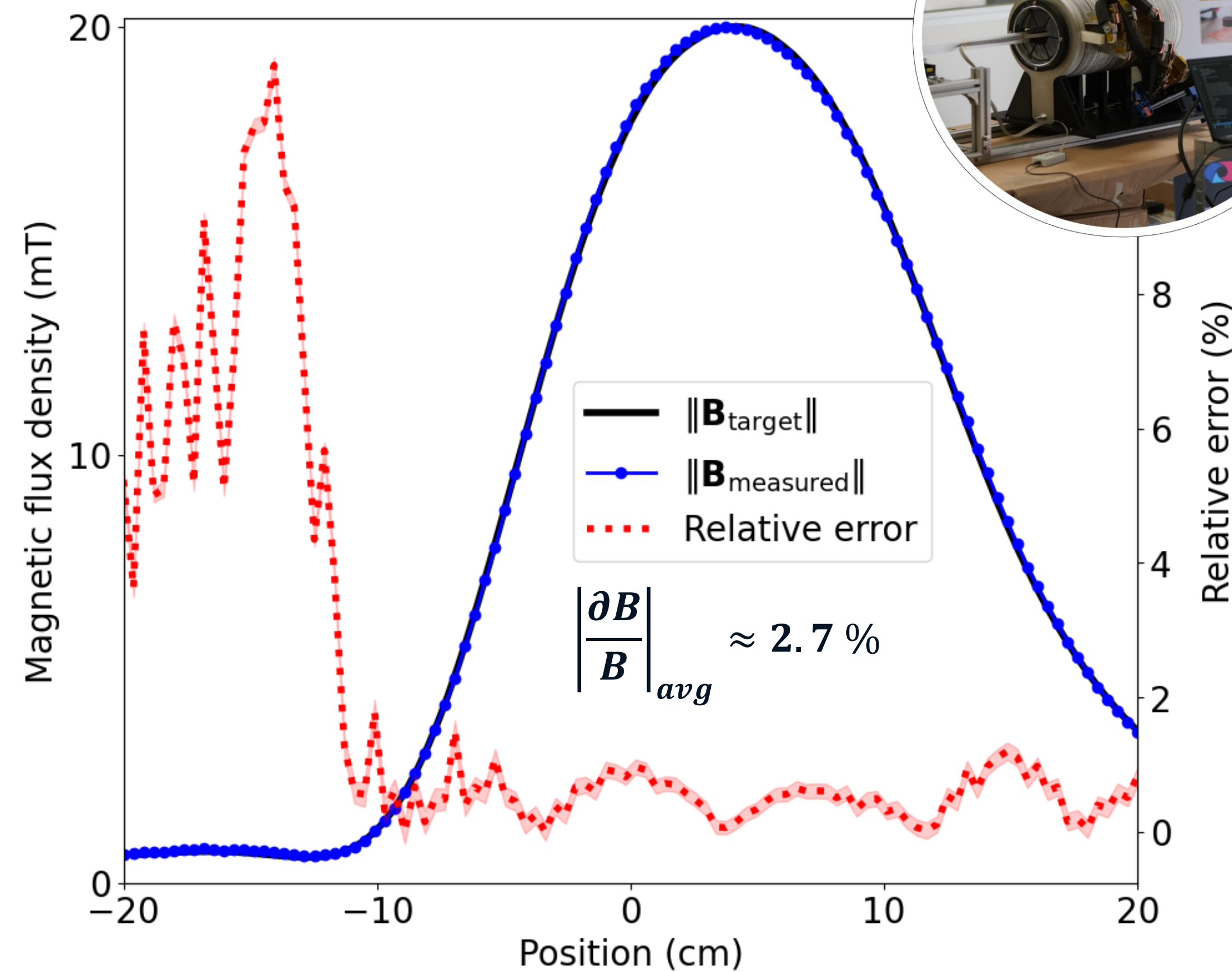
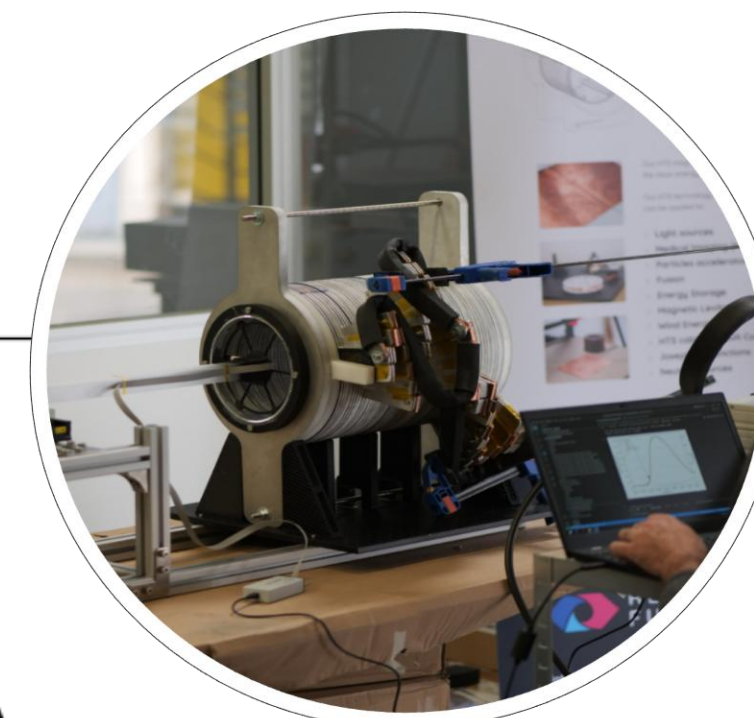
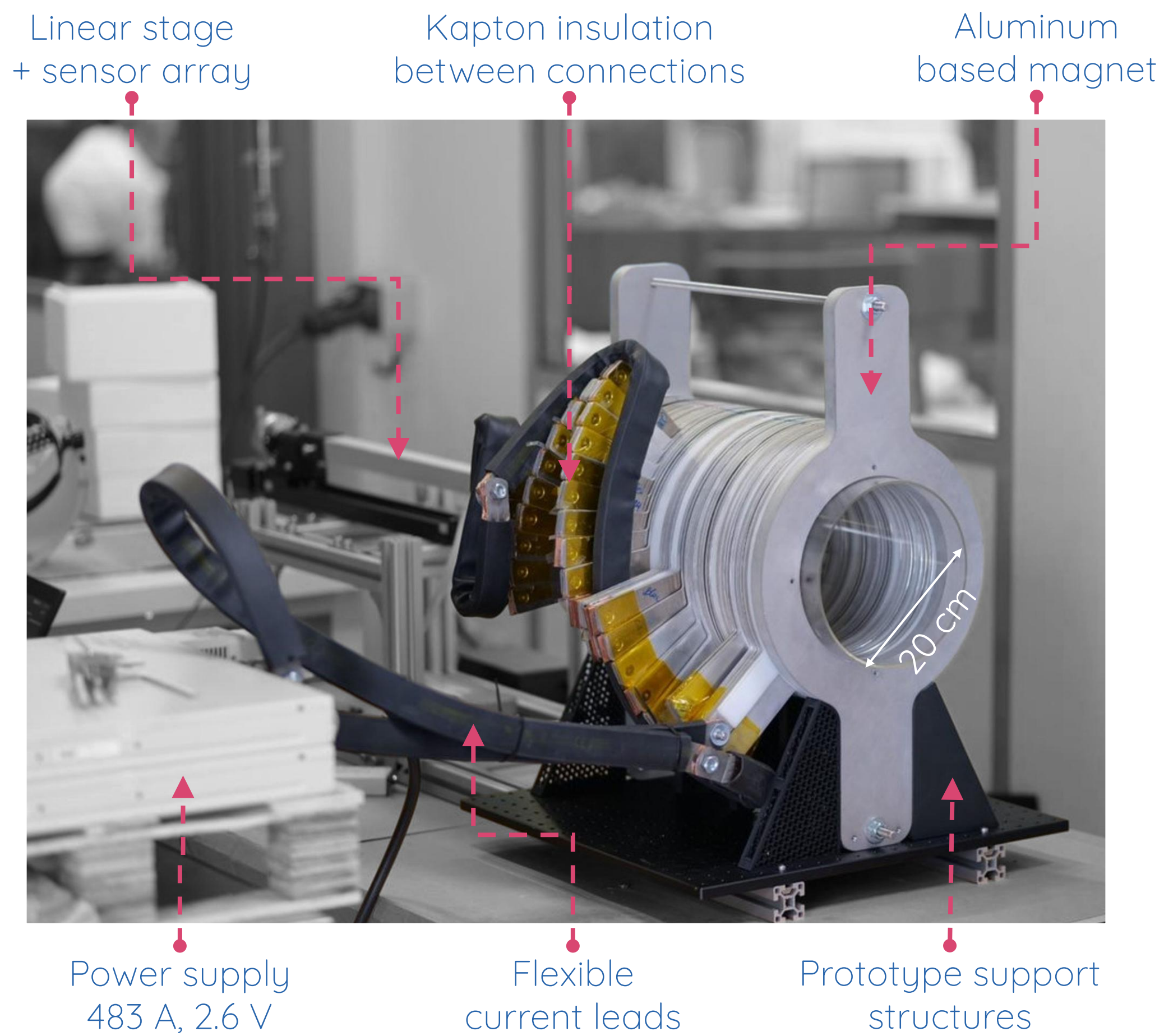

Pereira Botelho et al., arXiv:2409.20143 (2024)



Uniformity of 40 ppm achieved in the volume of interest

One order of magnitude better than the required accuracy for stellarator fields

Manufacturing

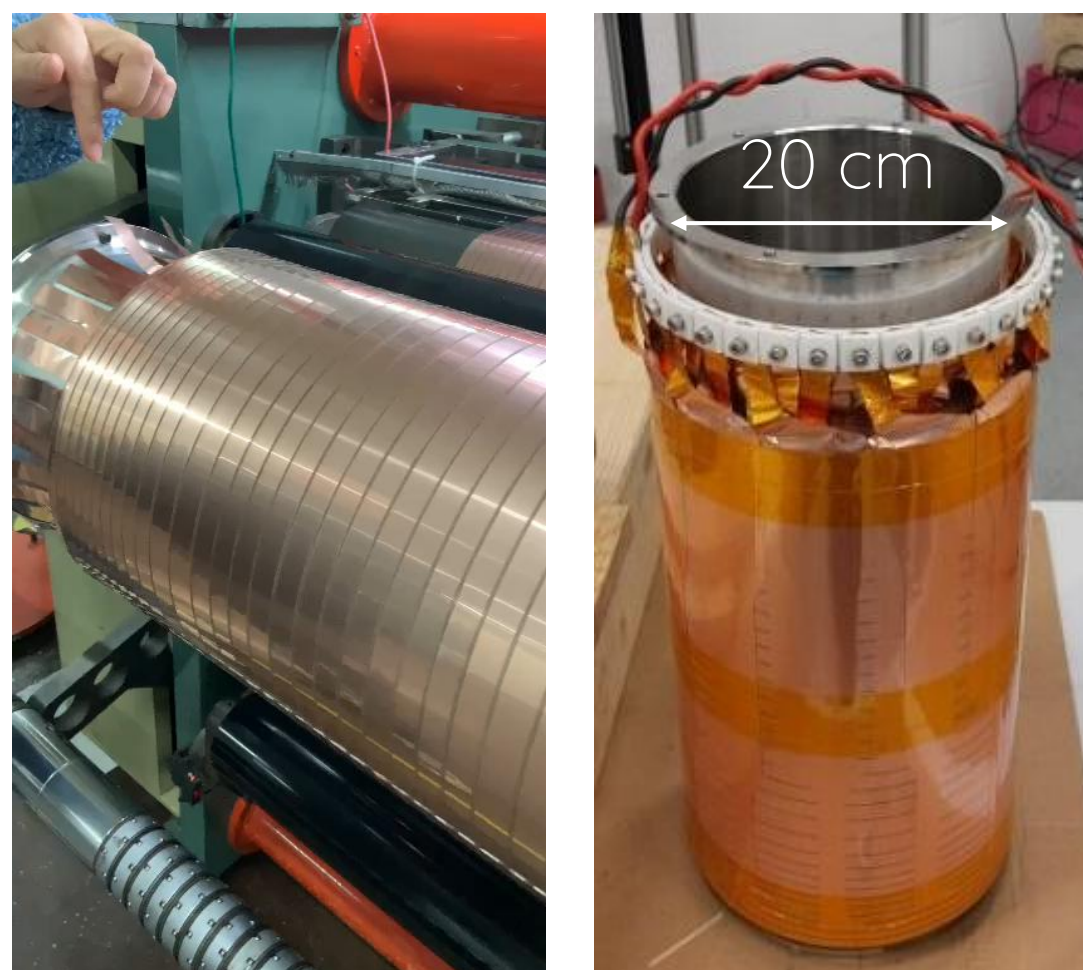

Liquid nitrogen (LN2)

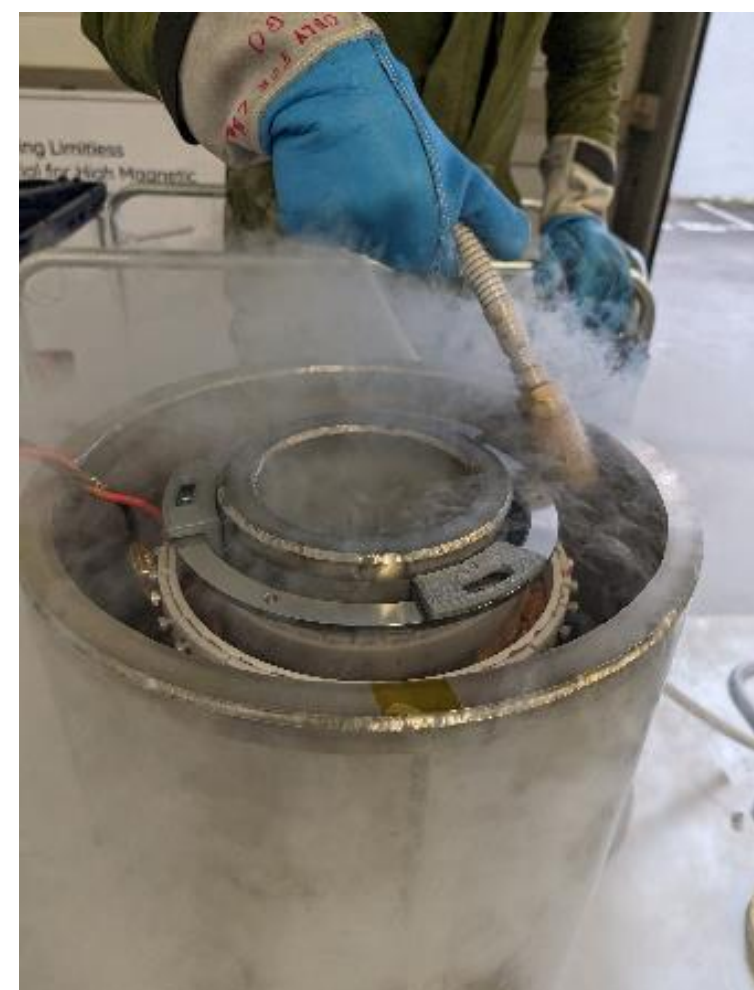

Nuclear magnetic resonance probe

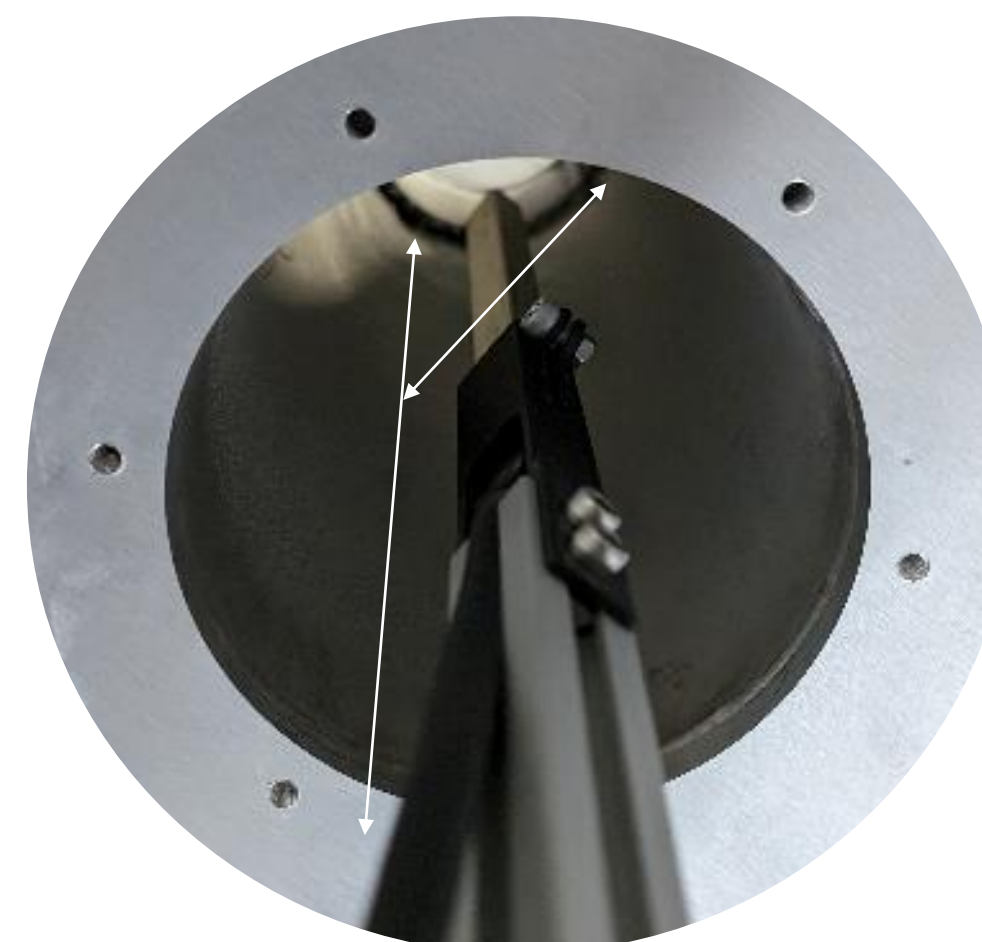

|B| field error [%]

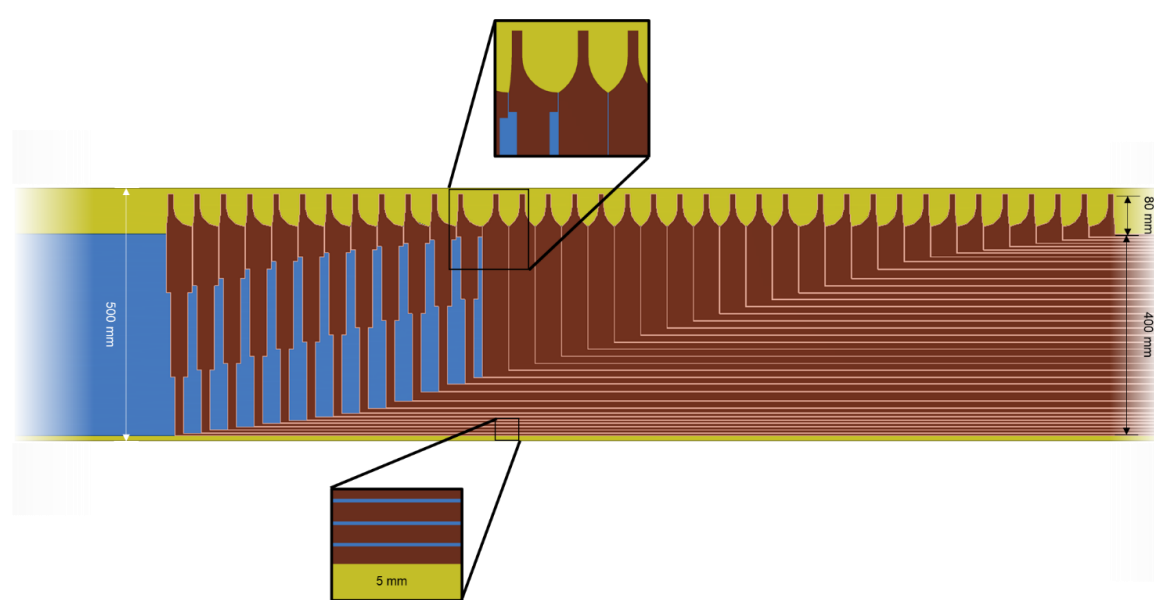
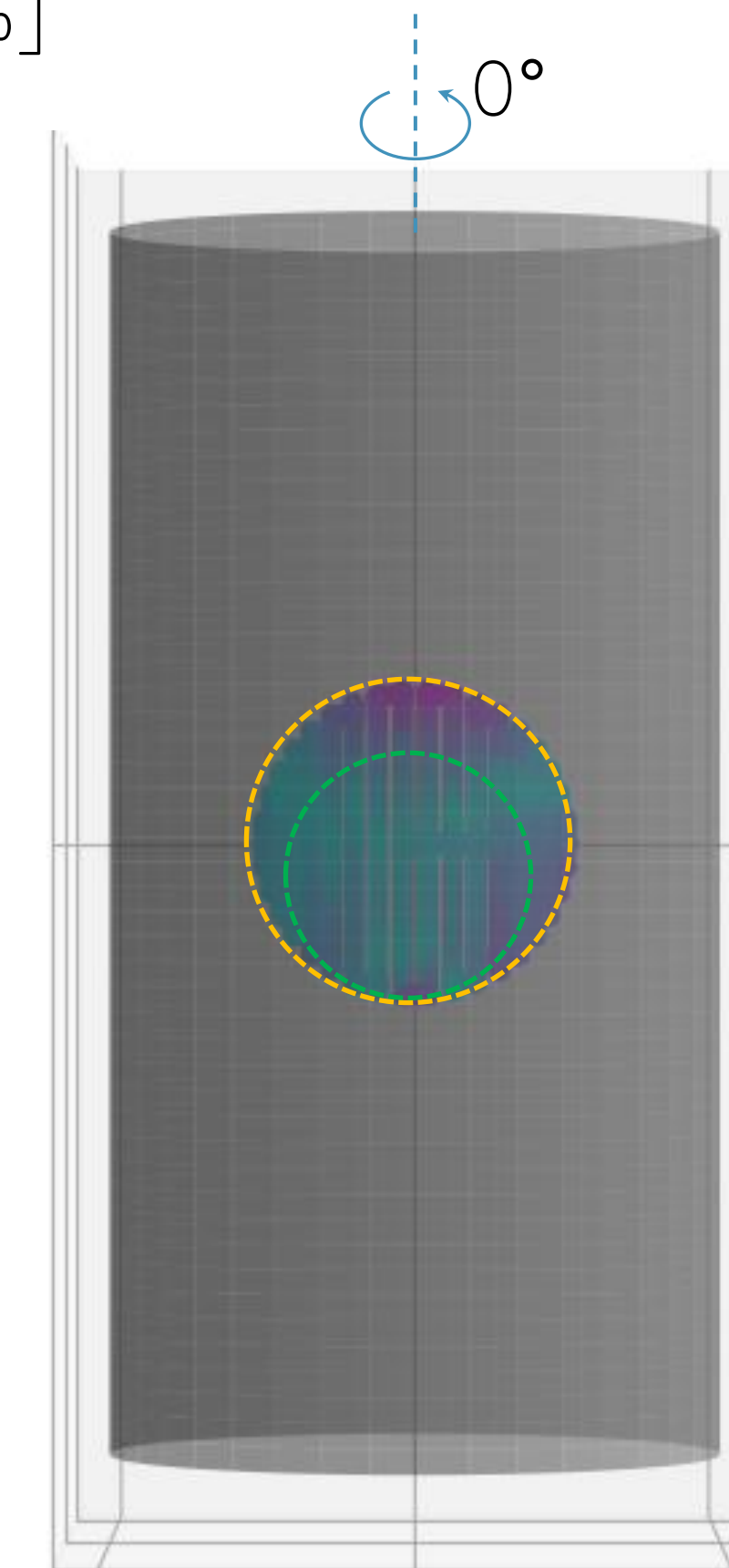
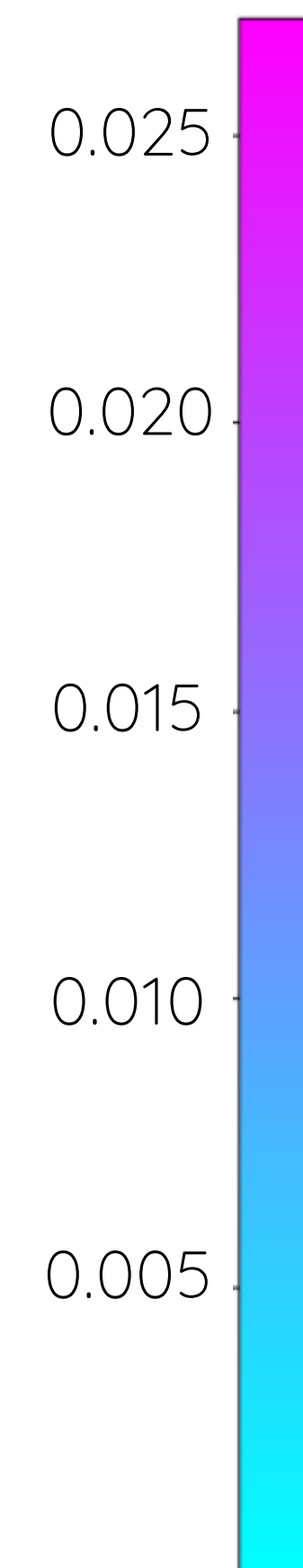

Field homogeneity @ 8 cm VOI			
	Model	As Built	Measured
ϵ_{max} [ppm]	40	80-220	152
V_{RMS} [ppm]	12.3	29 - 54	40.5

Pereira Botelho et al., arXiv:2409.20143 (2024)



Simplifying the design of stellarator magnets

Conventional way

Conformal surface

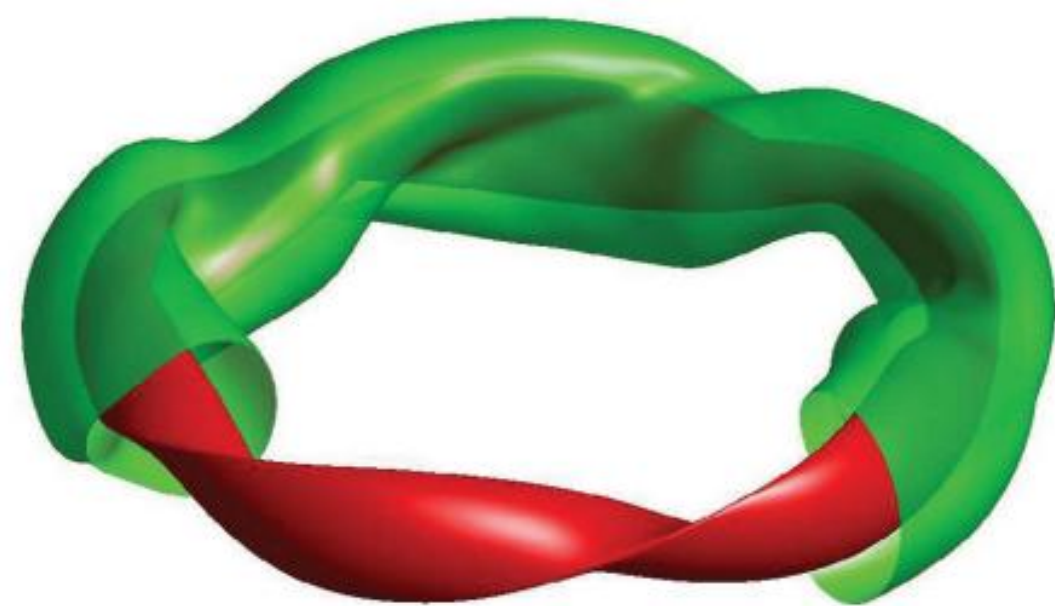

Electric current solution

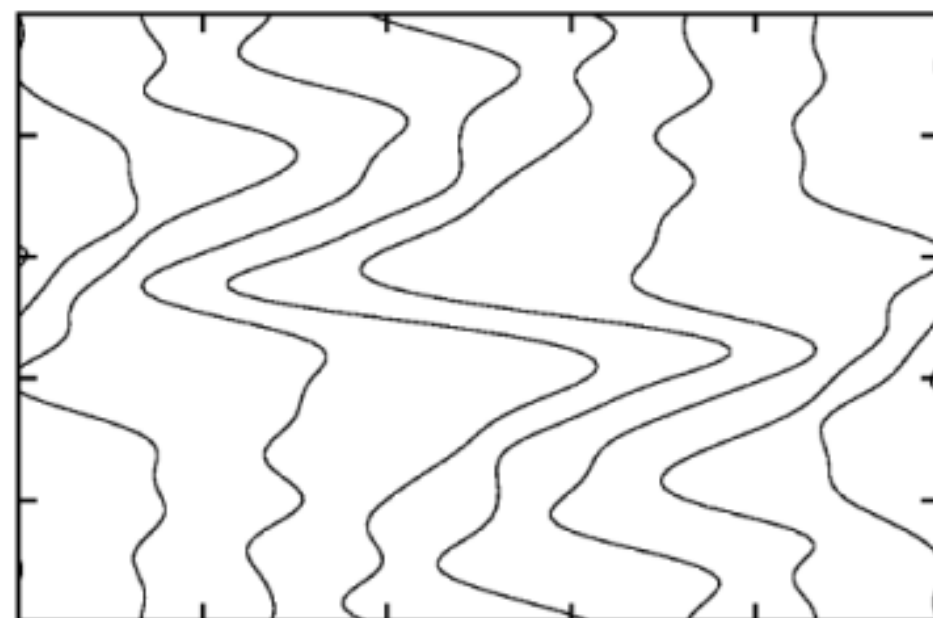

Coil spatial optimization

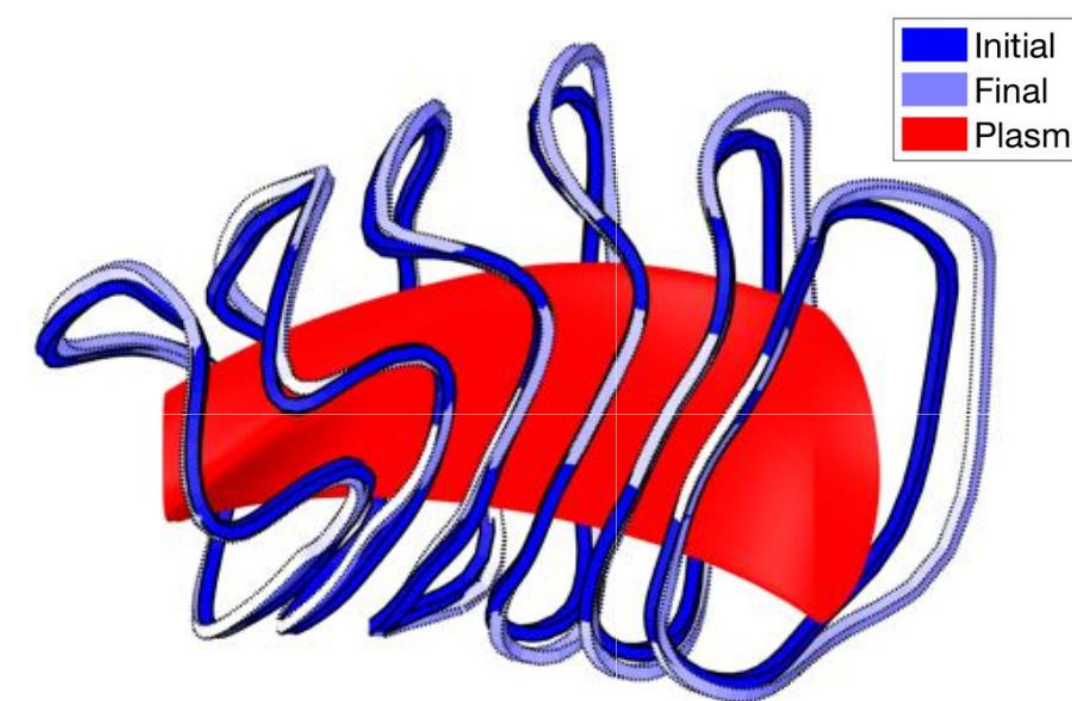

Magnet design

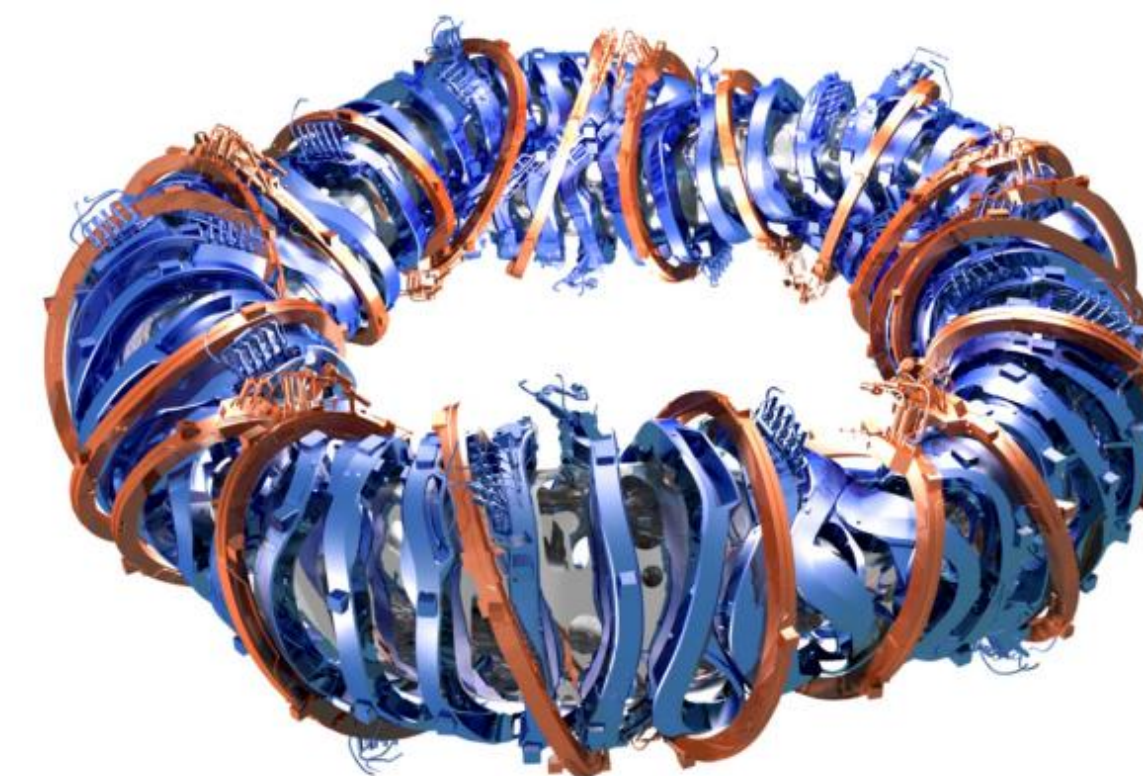

Renaissance Fusion way

Cylindrical surfaces

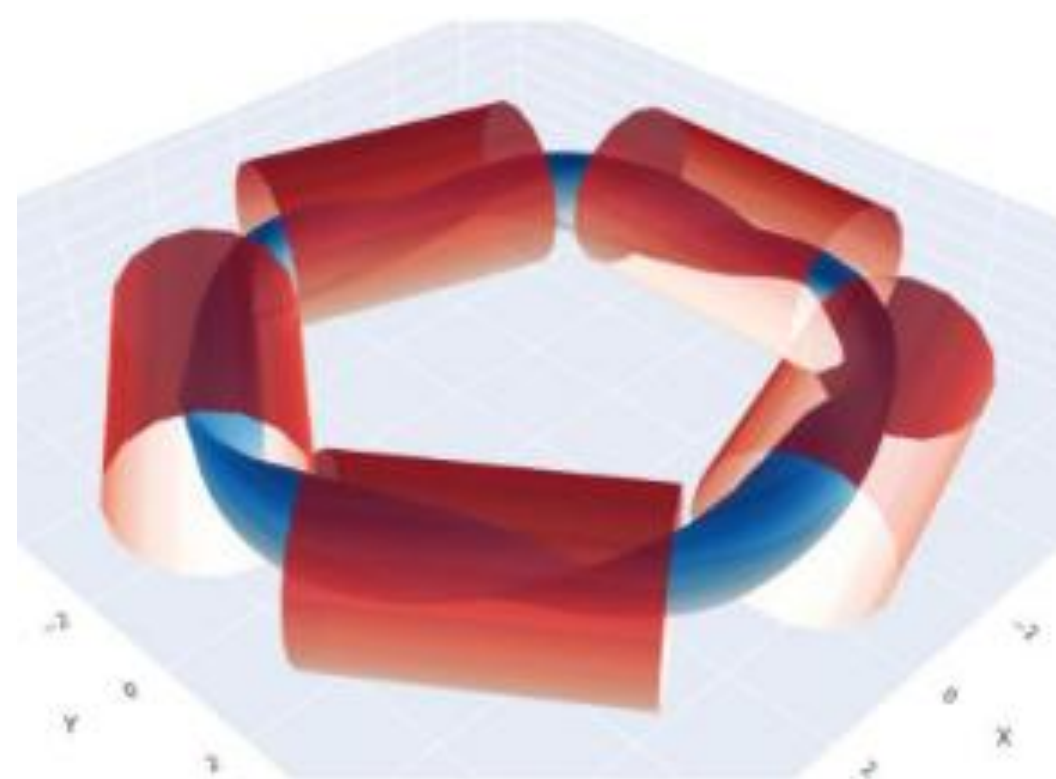

Electric current solution

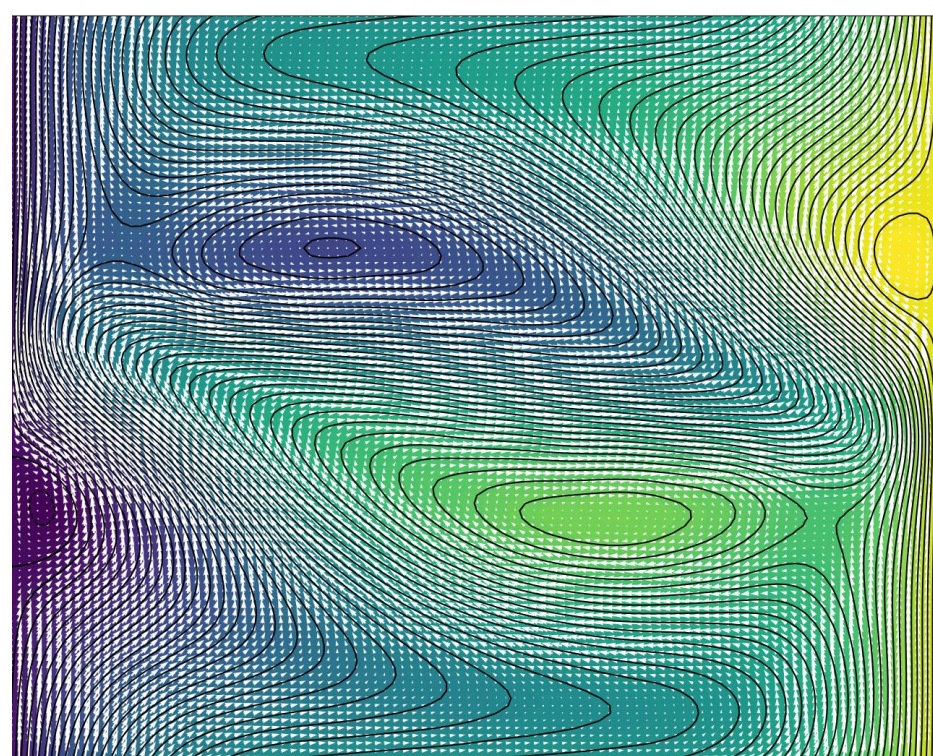

Engravings optimization

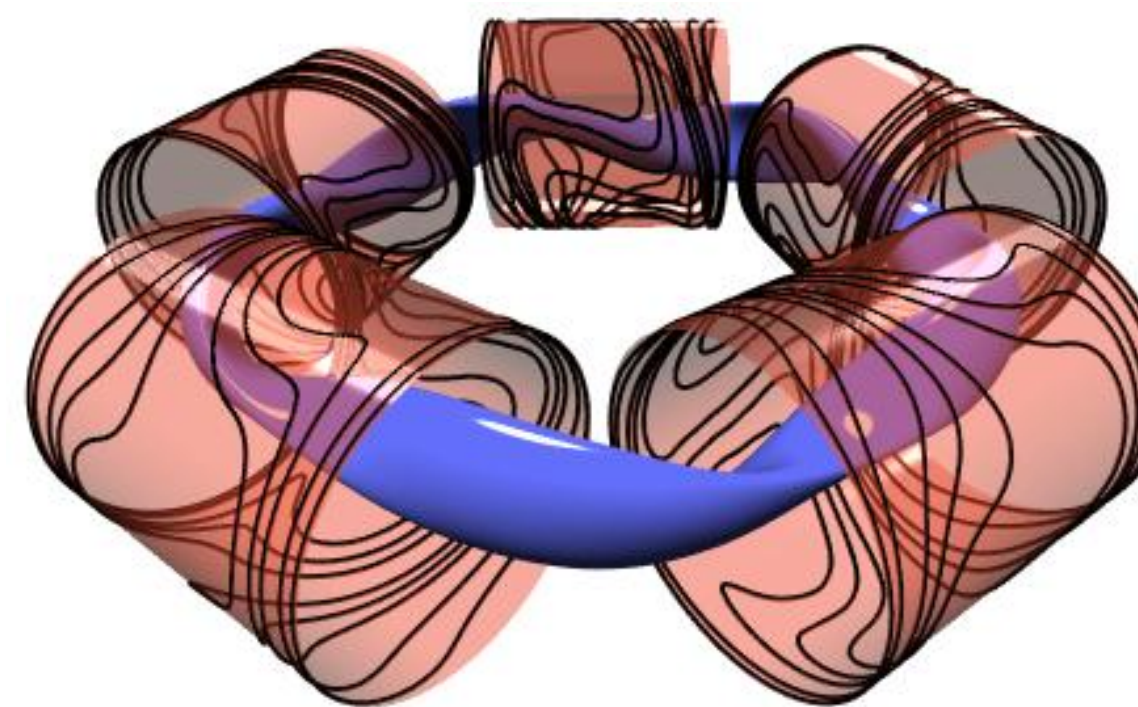

Magnet design

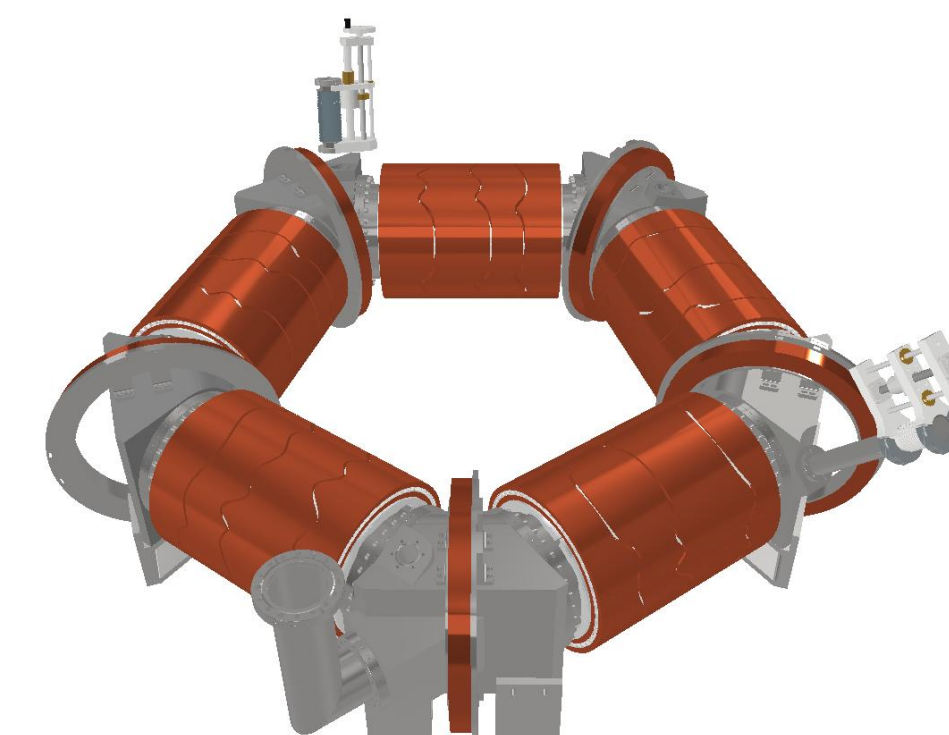



Trade-off between current complexity and field precision

Optimization of planar coils for improved solution

Current distribution at Coil Winding Surface (CWS)

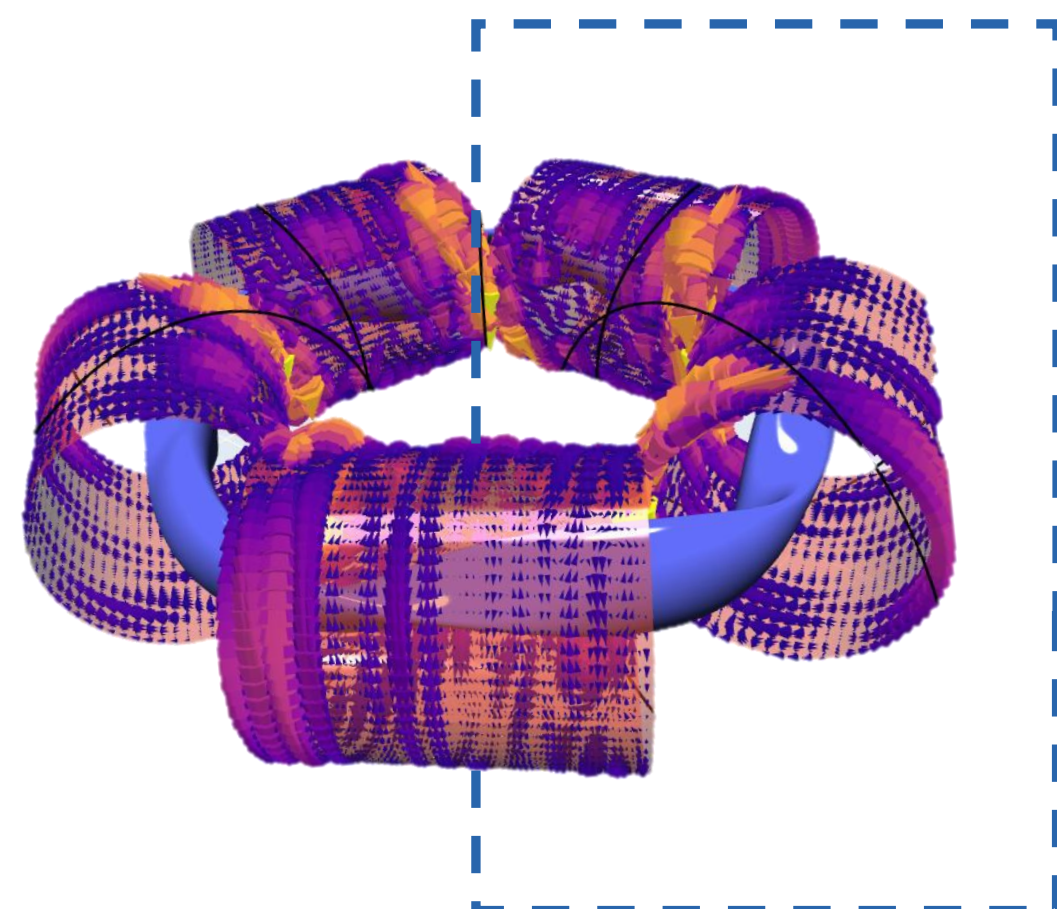

Unwrapped cylinder

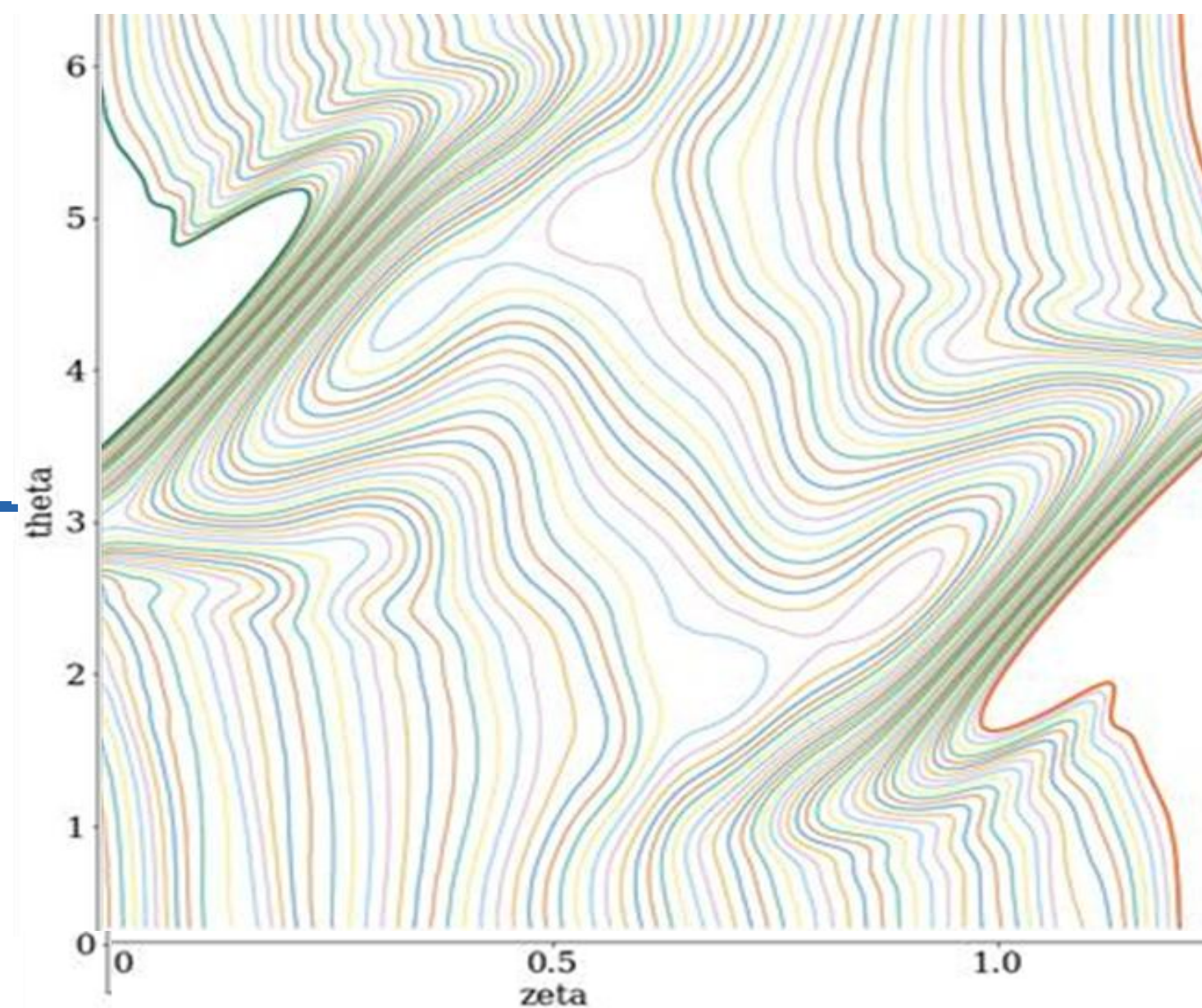

Max error : ~4.90%
Mean error : ~0.52%

Poincaré plot: W7X magnetic surfaces

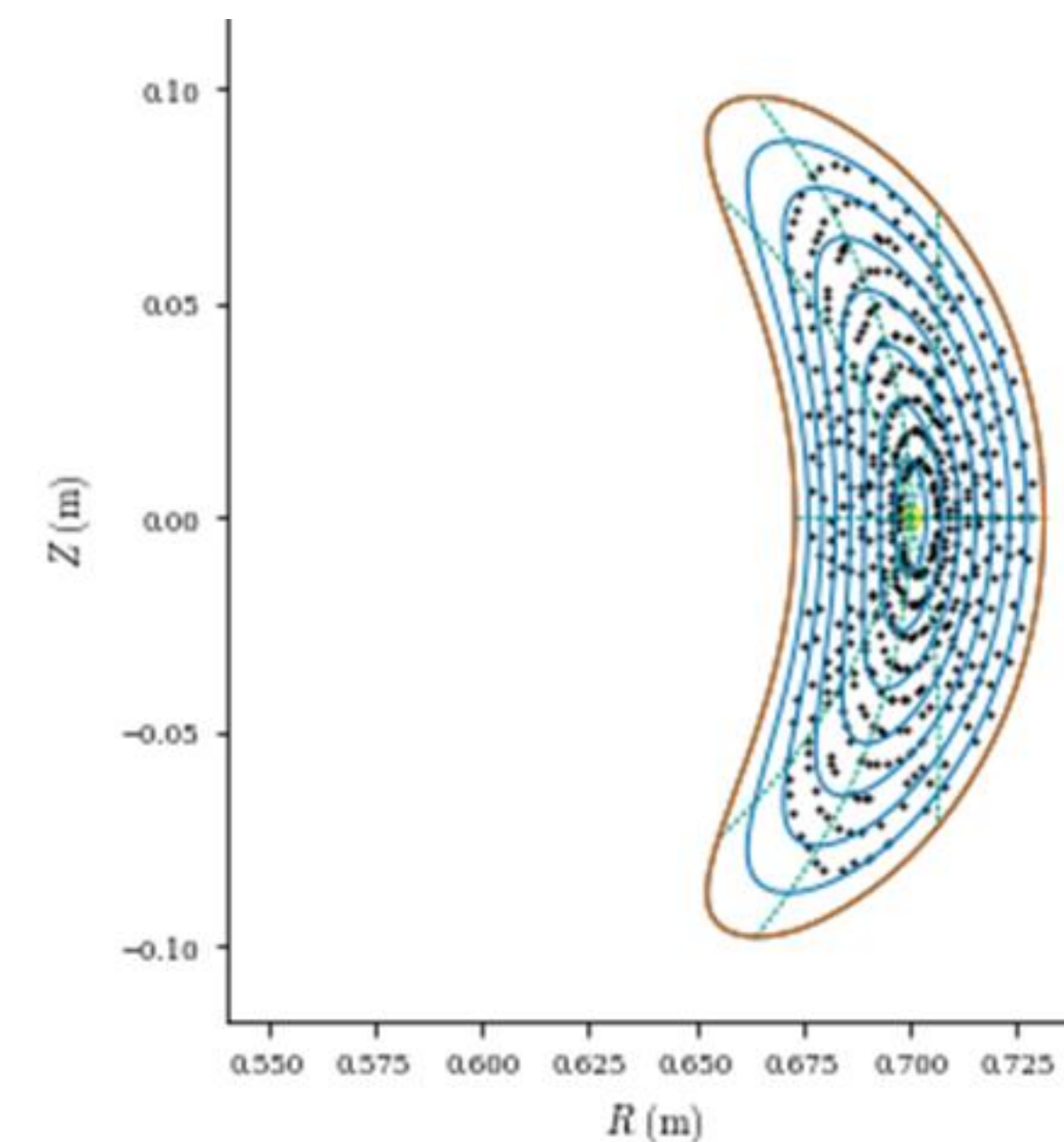

— target
● simulation

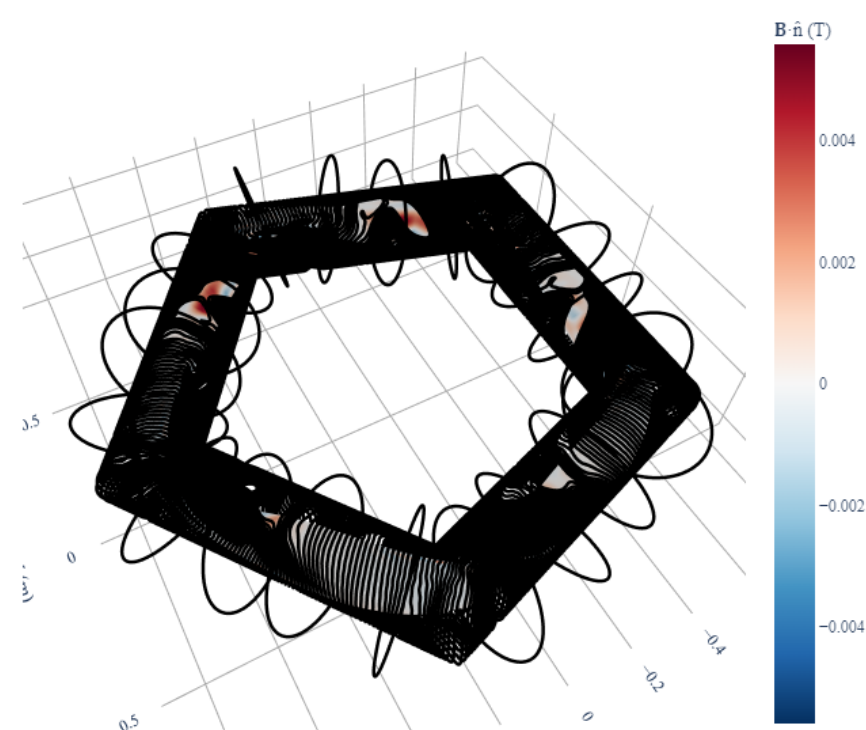



Corrugated copper stellarator magnets preliminary design and diagnostics demonstration

Target vacuum chamber pressure 10^{-7} mbar in Liquid Nitrogen bath

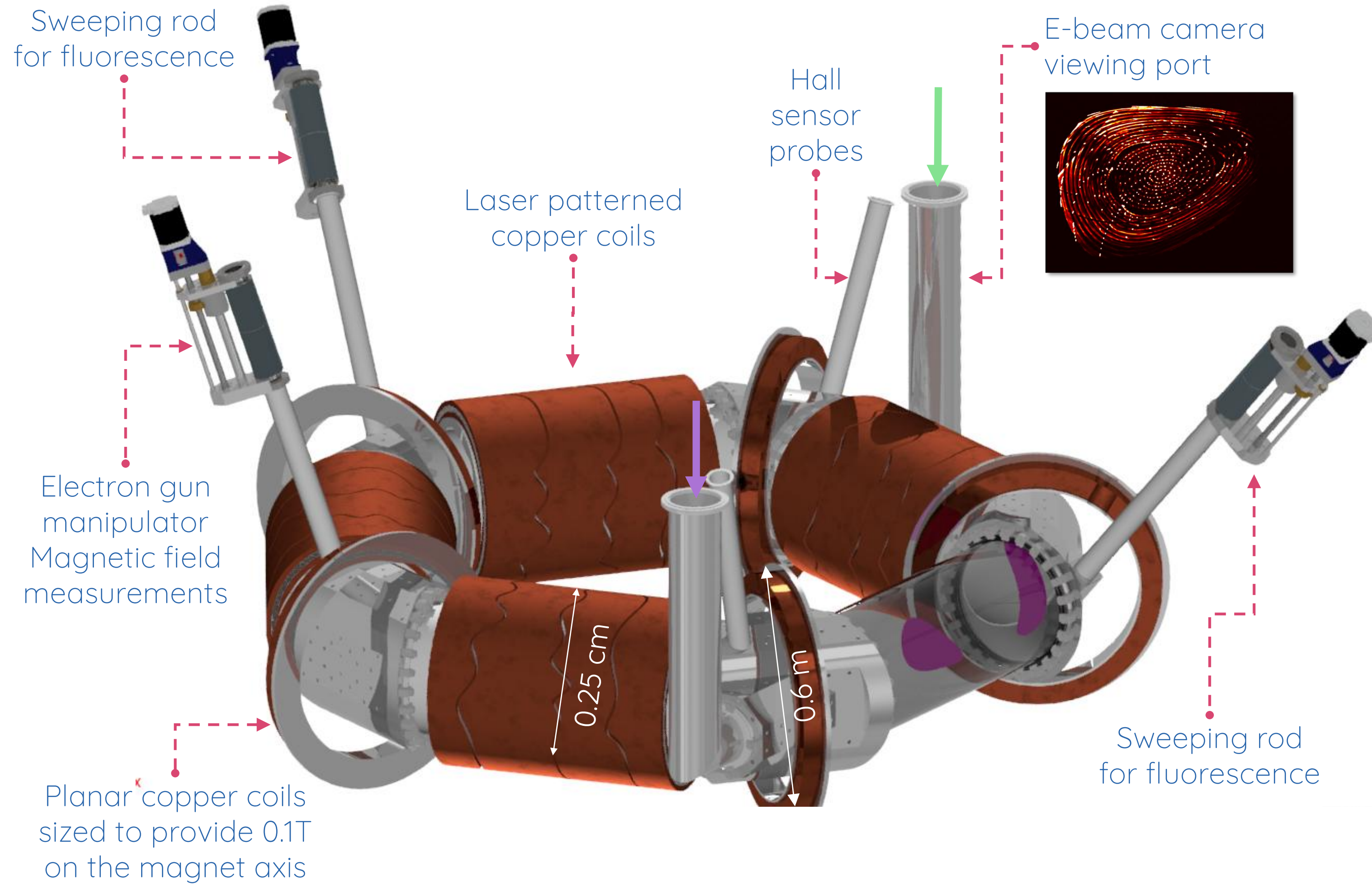

Viewing ports with mirrors

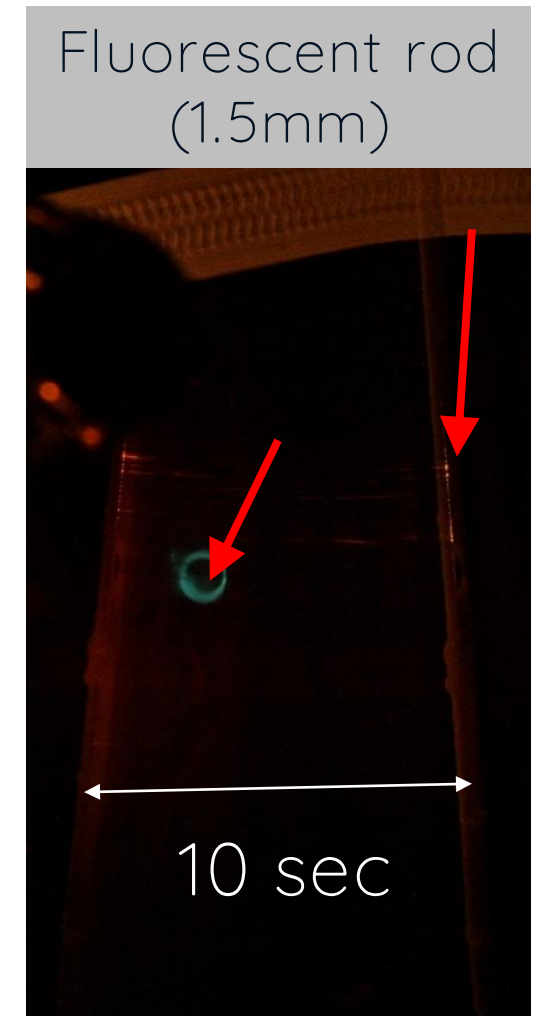
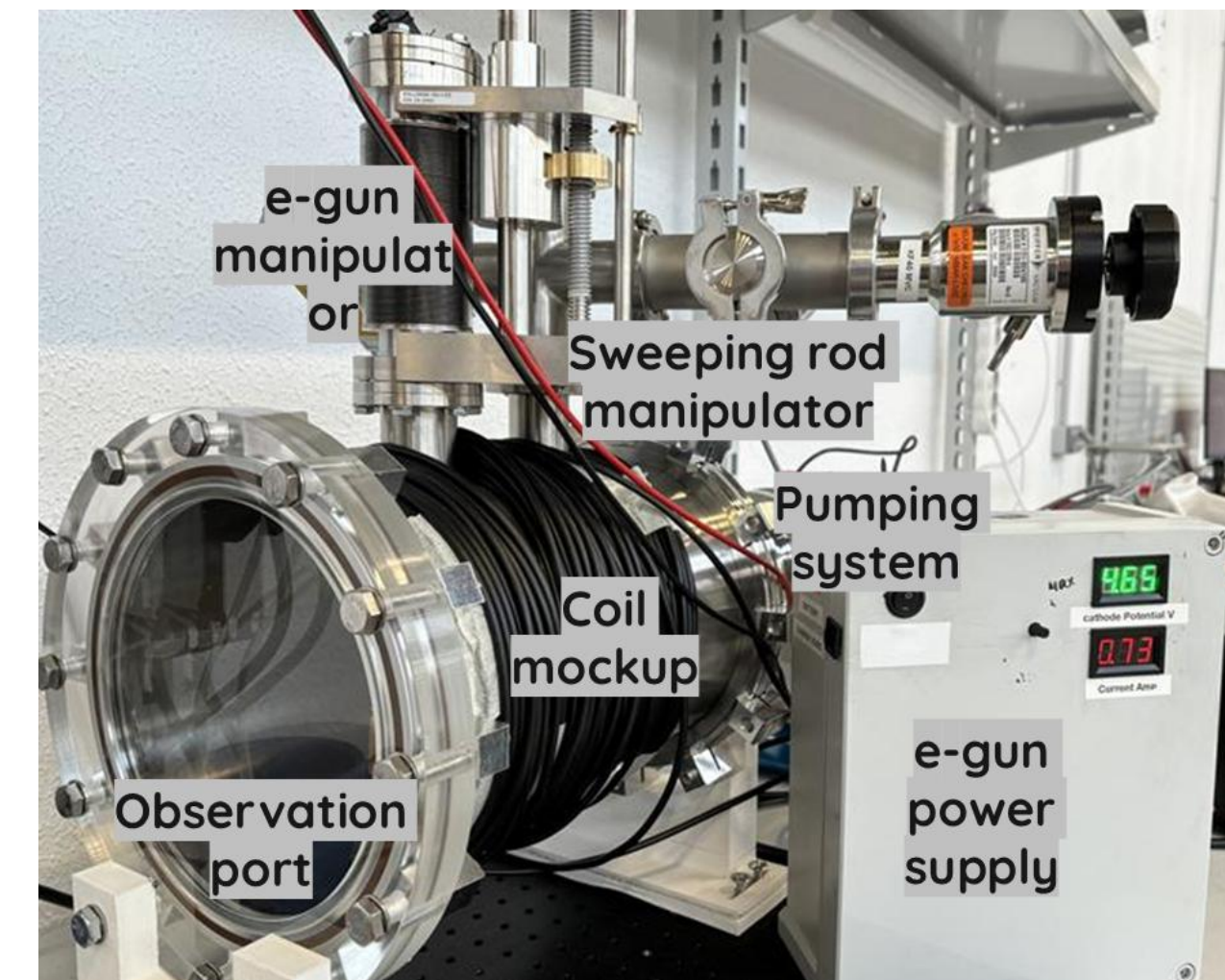
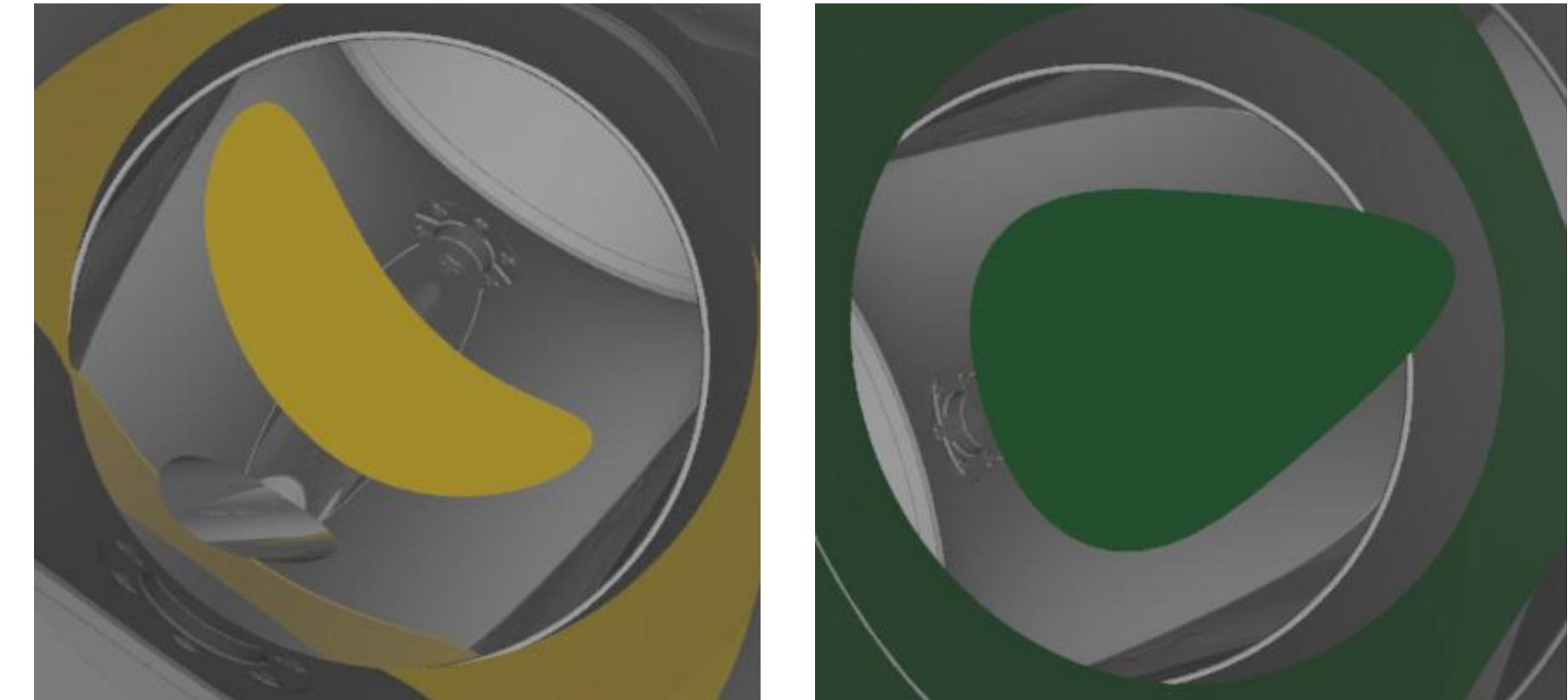



Enabling robust HTS magnets with increasing size & field

Magnet overview

Nicola-20 Nicola-100

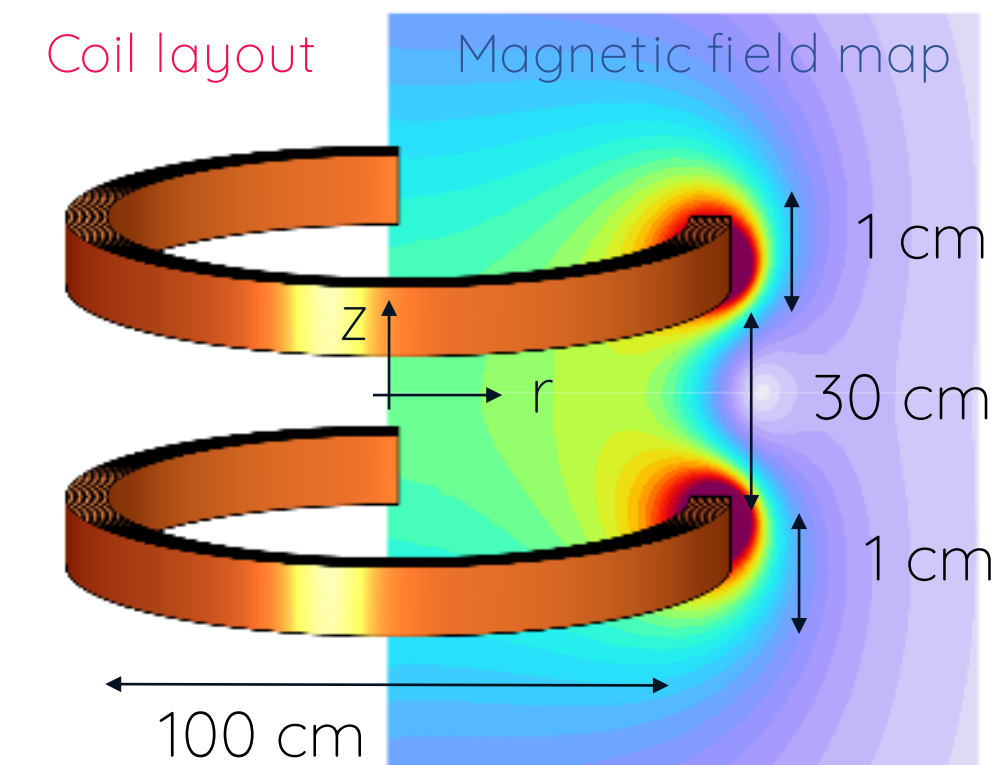
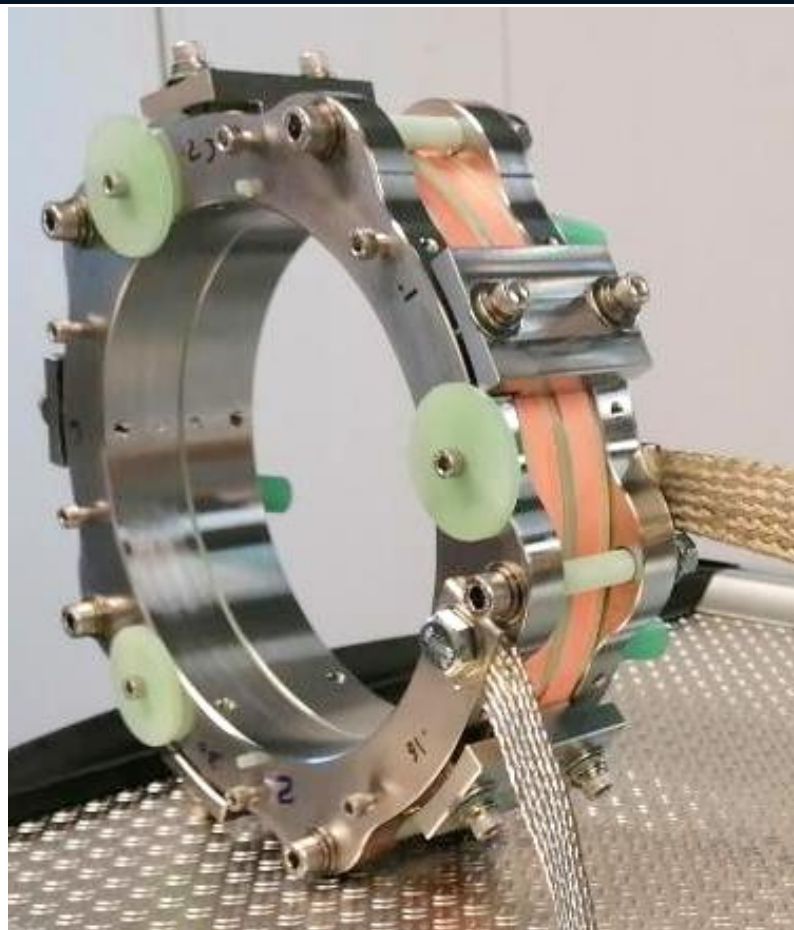

Double Pancake Coil
Mechanical structure, layer jumps

Helmholtz type Coil
Liquid metal integration

Magnetic field (peak)	≈ 1 T	≥ 6 T
Magnet Ø	20 cm	1.1 m
Nominal current	140 A	1.8 kA
Stored Energy	0.3 kJ	500 kJ
Temperature	77 K	20 K
Cryostat Pressure	atm	Vacuum



Nicola100 HTS magnets operating at 20 K, provides > 1T peak in the 10 cm wide LM channel

0.93 T avg in the LM channel, with an 80 % load line on the HTS conductor

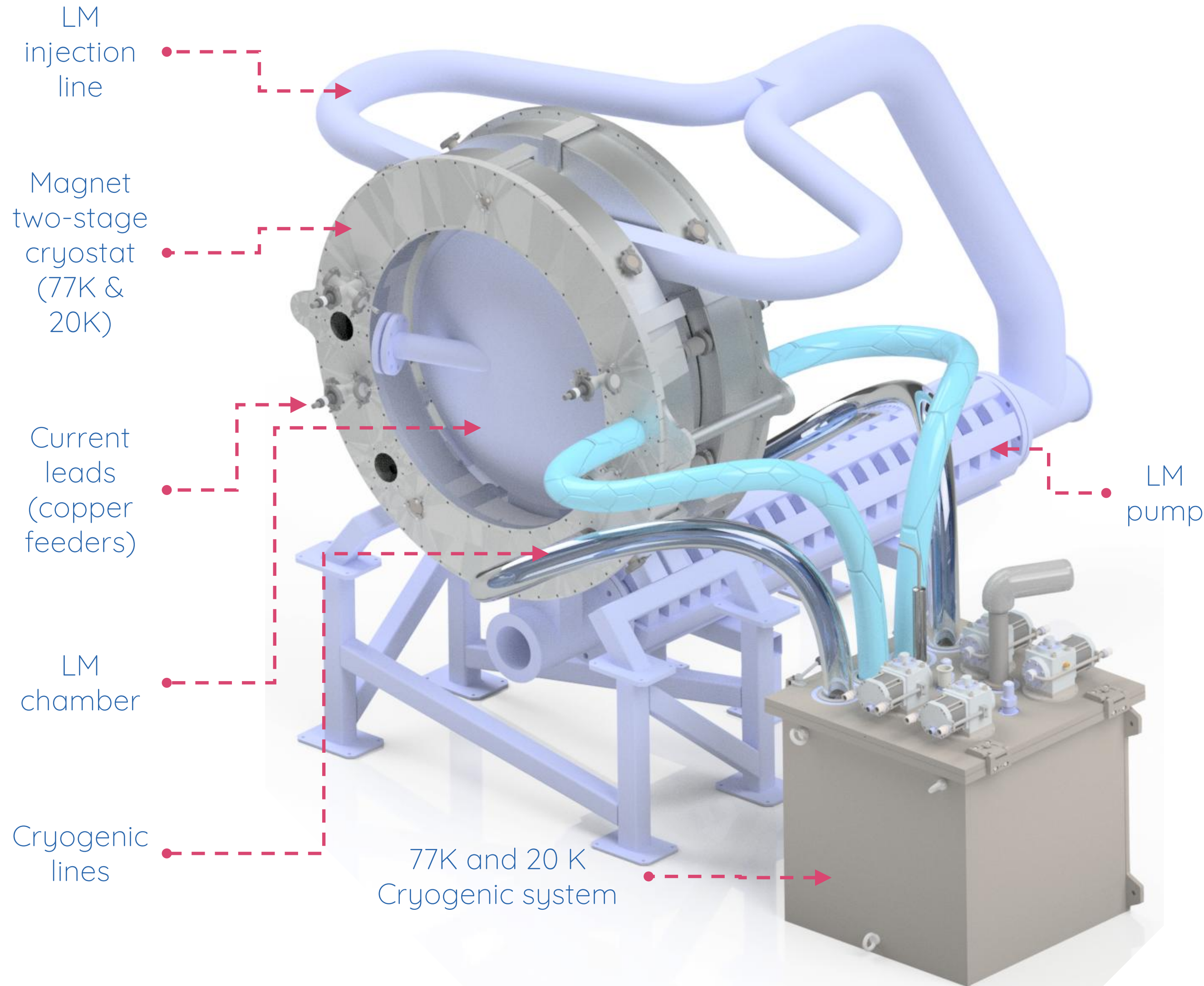

Optimization of coil position and thermal gradient

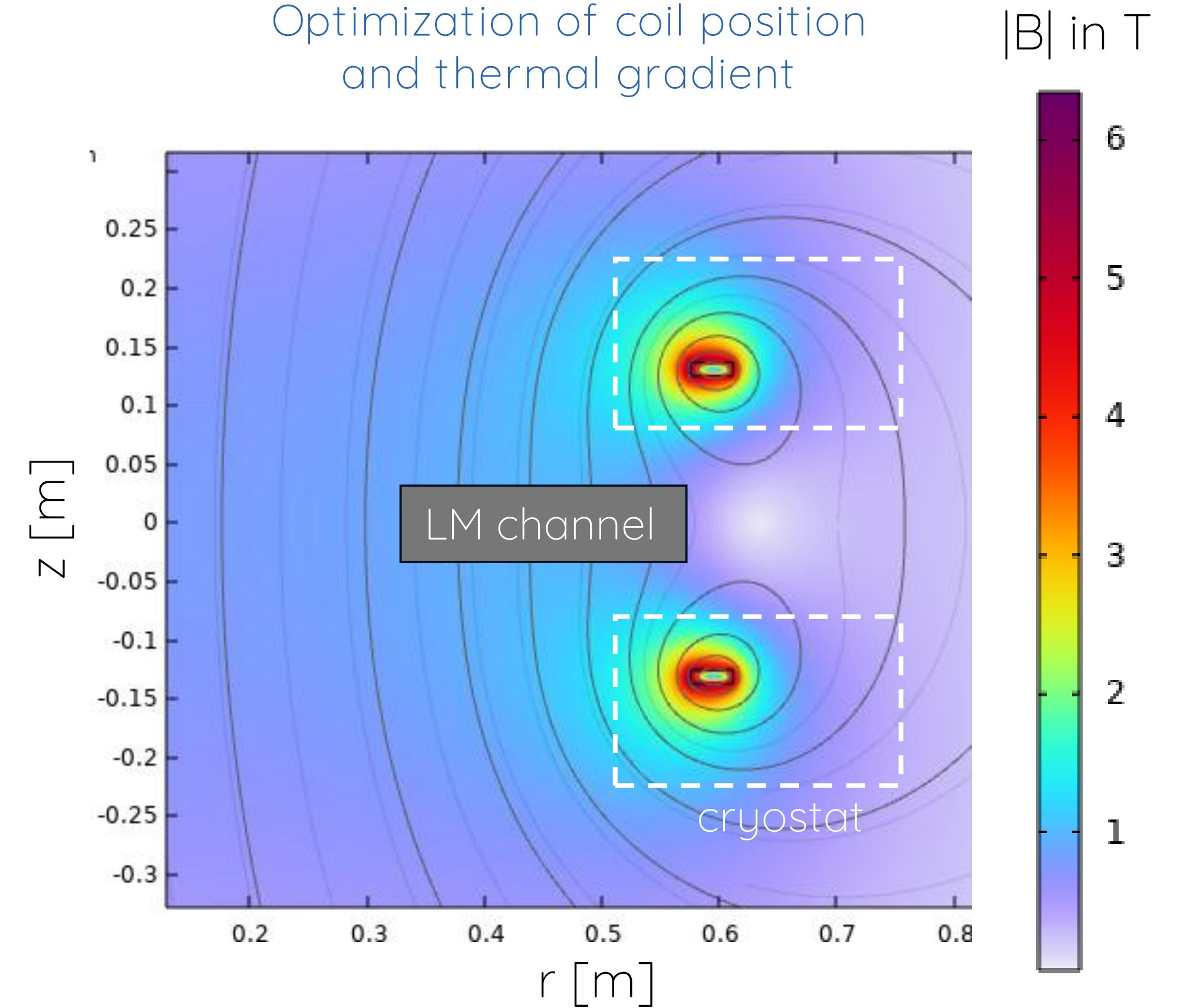



Cryogenic system design, built and tested, delivering 250W @20K using pressurized helium gas

120 W @20K on the HTS coils and current leads

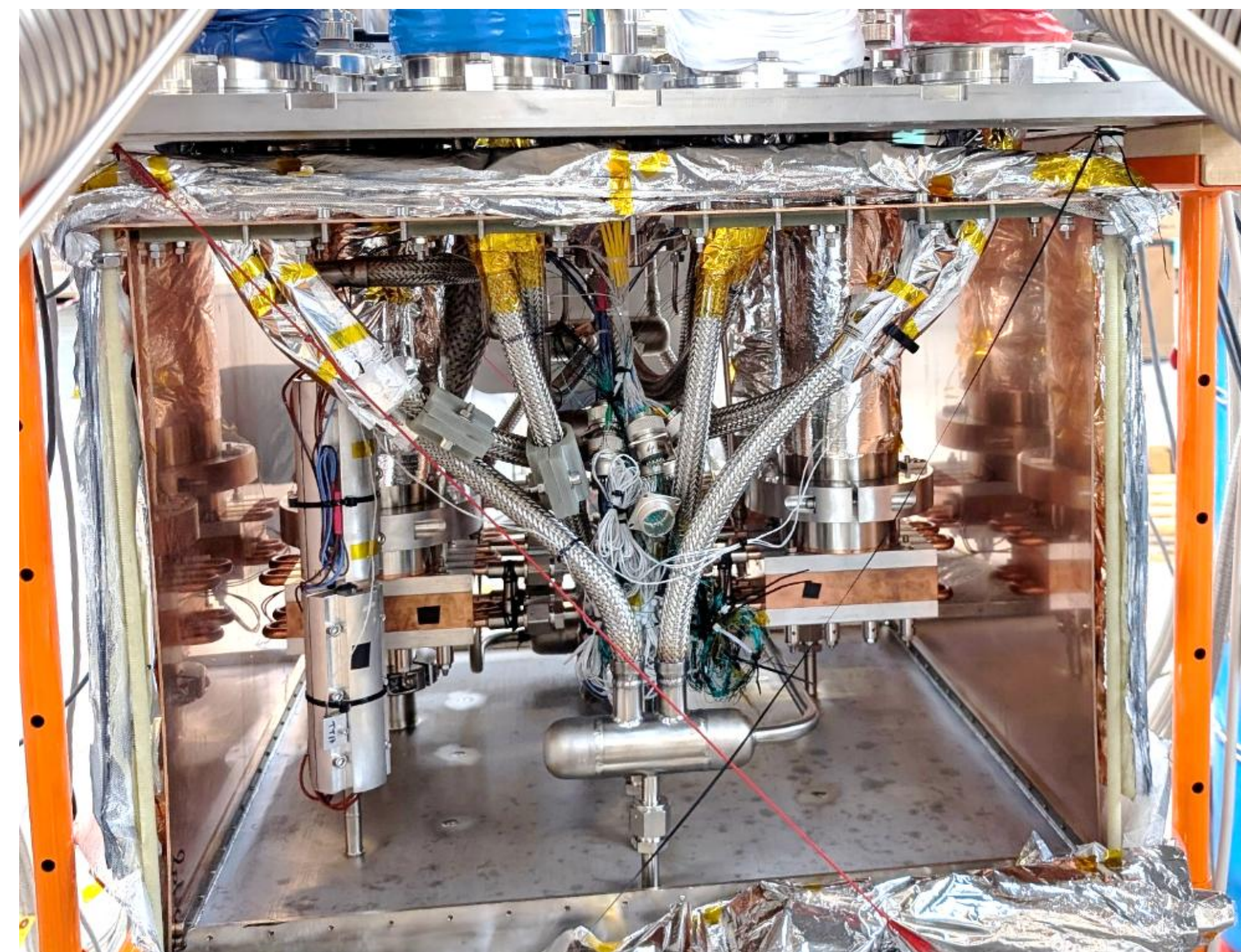
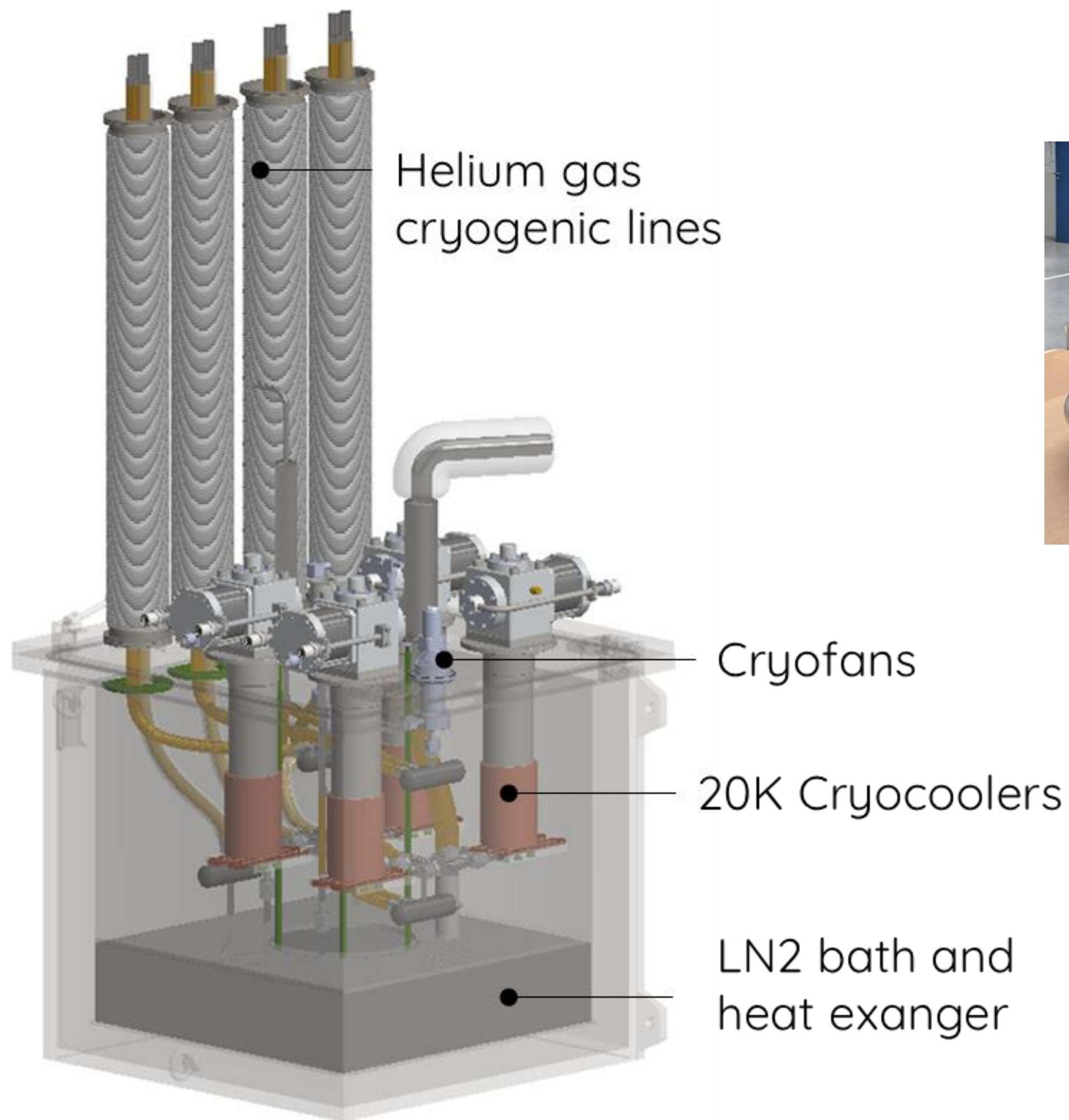

→ Cryogenic system could reach 17 K under load allowing for a 10% field increase



Developed EM-thermo-mechanical models to optimize manufacturing, and lead to a x7 reduction in charging time

Calibration of contact resistance as a function of radial pressure

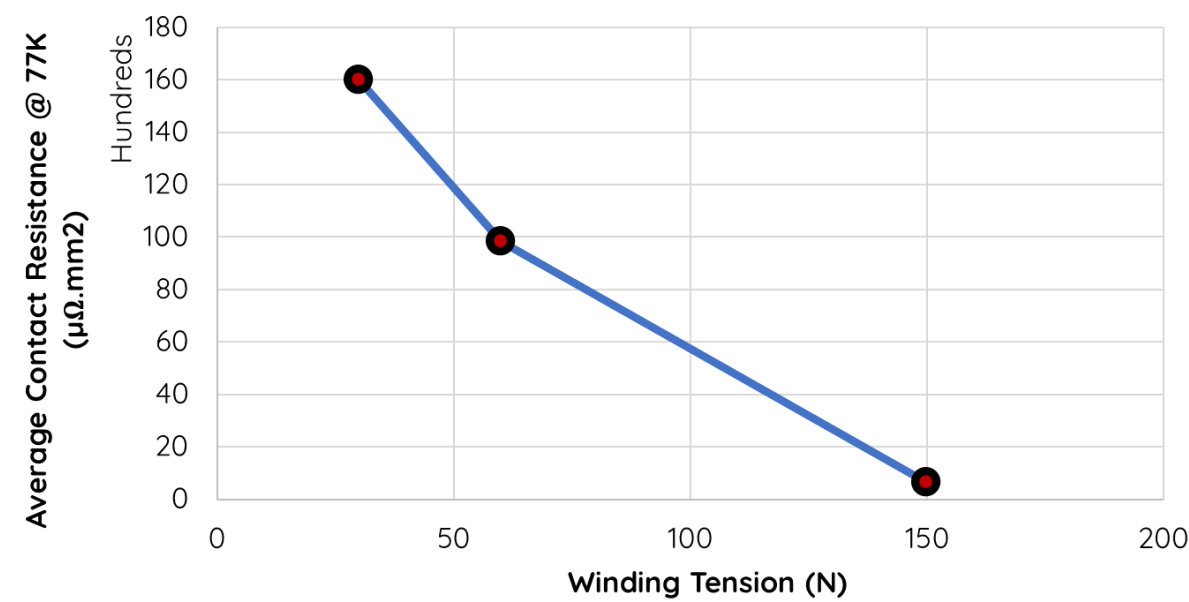
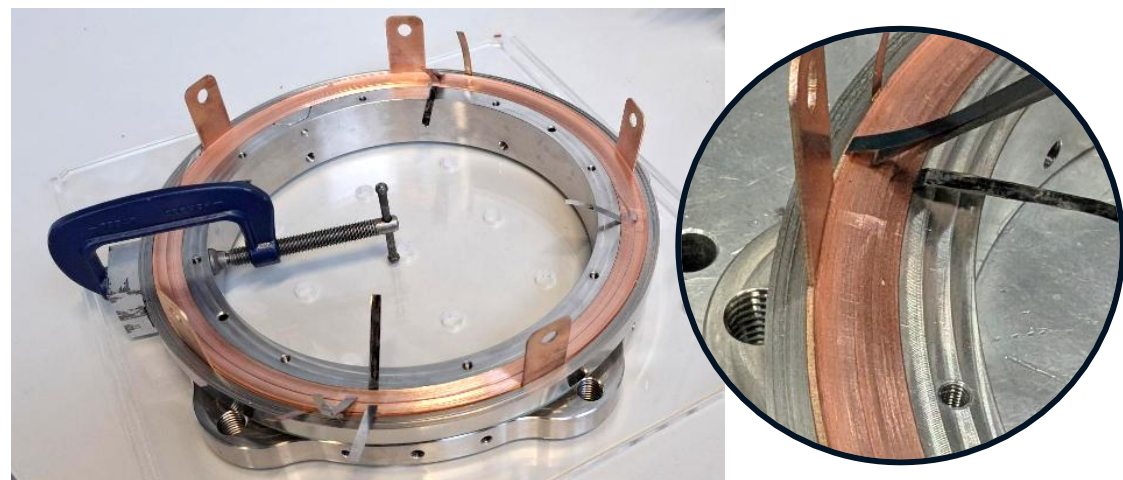

Thermo-mechanical modelling of contact pressure as during assembly of magnet

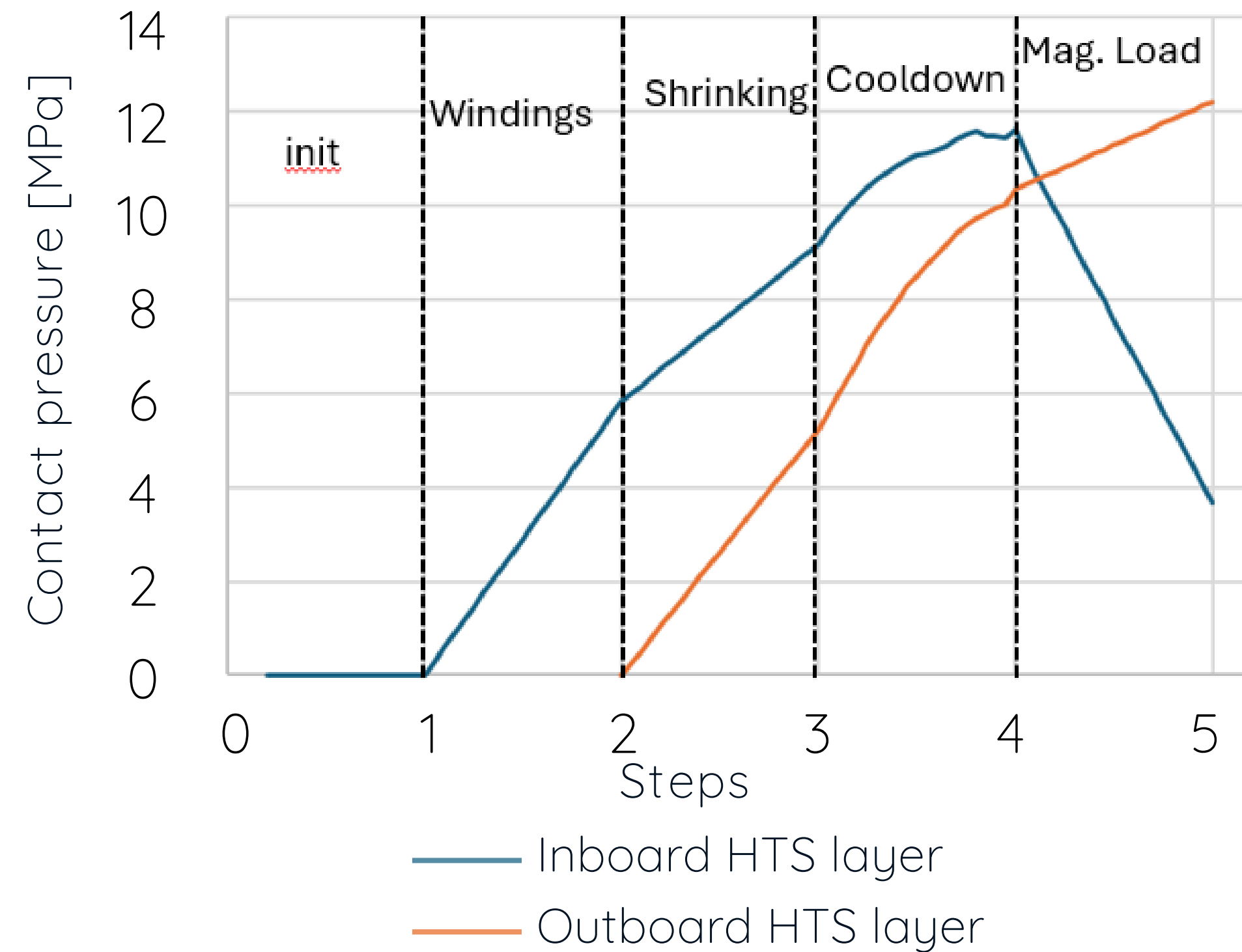

Coupled EM-thermal simulations

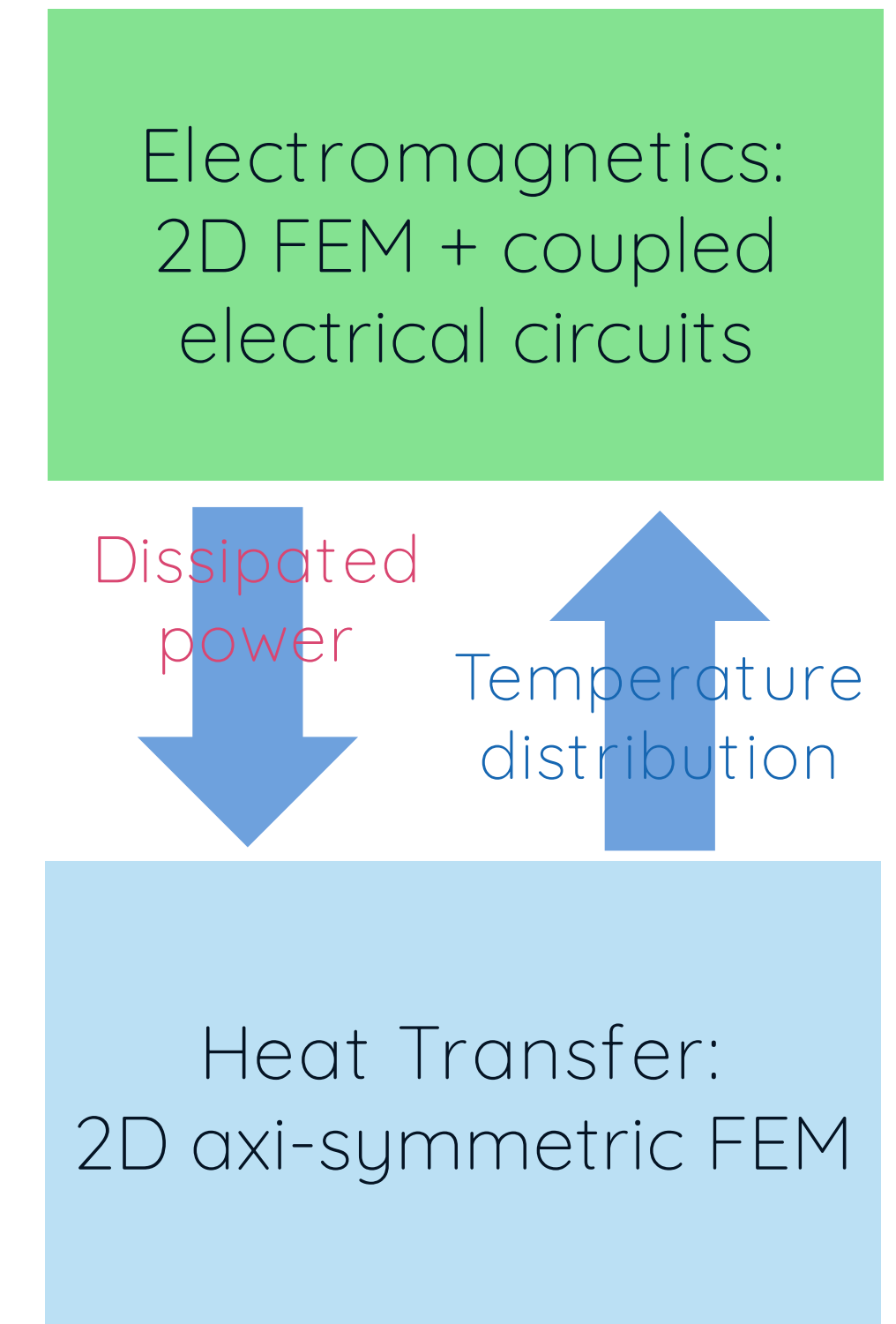



Developed EM-thermo-mechanical models to optimize manufacturing, and lead to a x7 reduction in charging time

Current and cooldown schemes

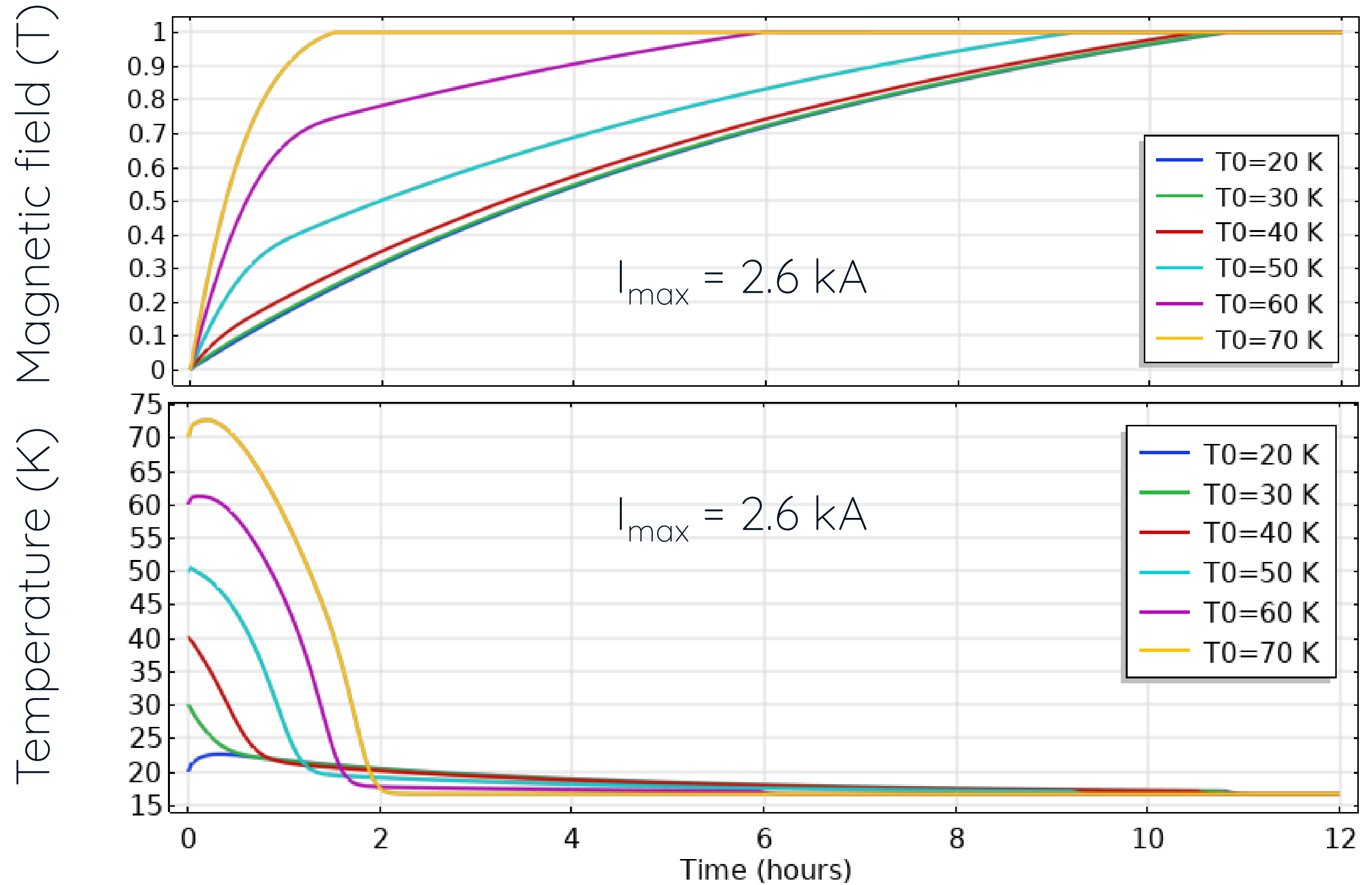
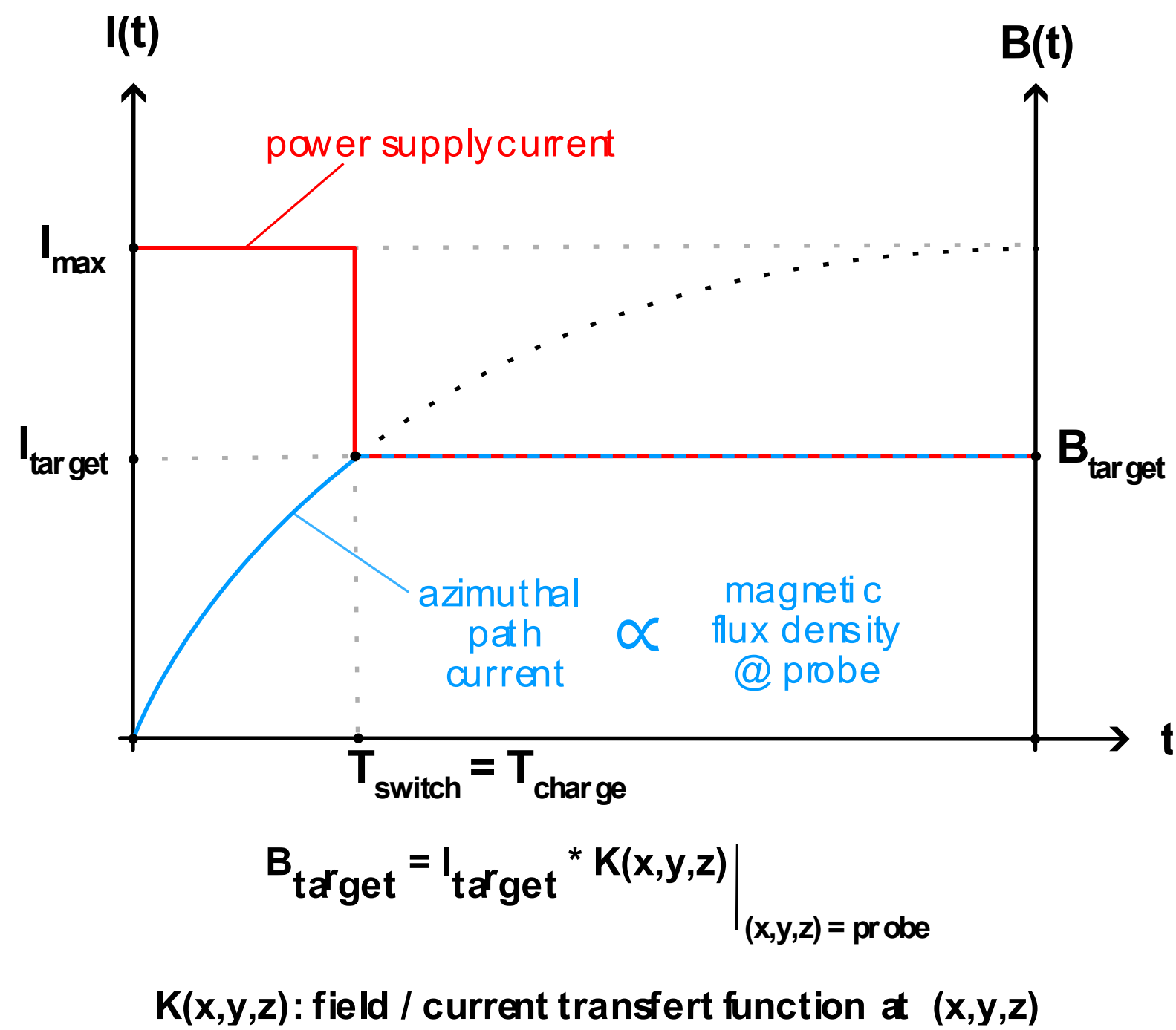

I_{max}	P_{diss}^{max}	Starting Temp	Max Temp	Charging time
1.8 kA	17 W	20K	23 K	>48h
2.6 kA	184 W	55K	56 K	~7h



Developed parallel winding machine with tension control and accurate guiding with laser measurements

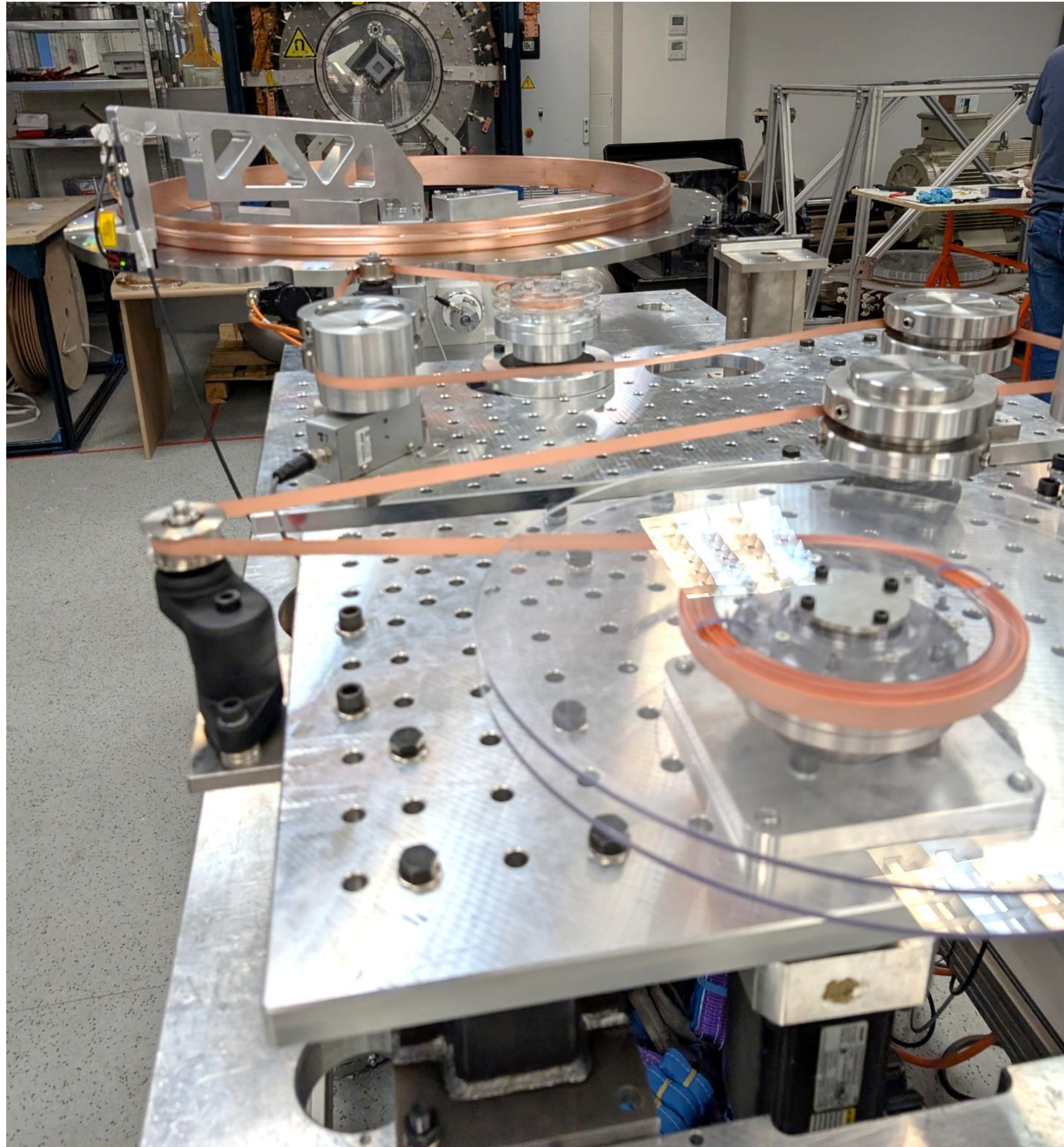



Magnet assembly in progress

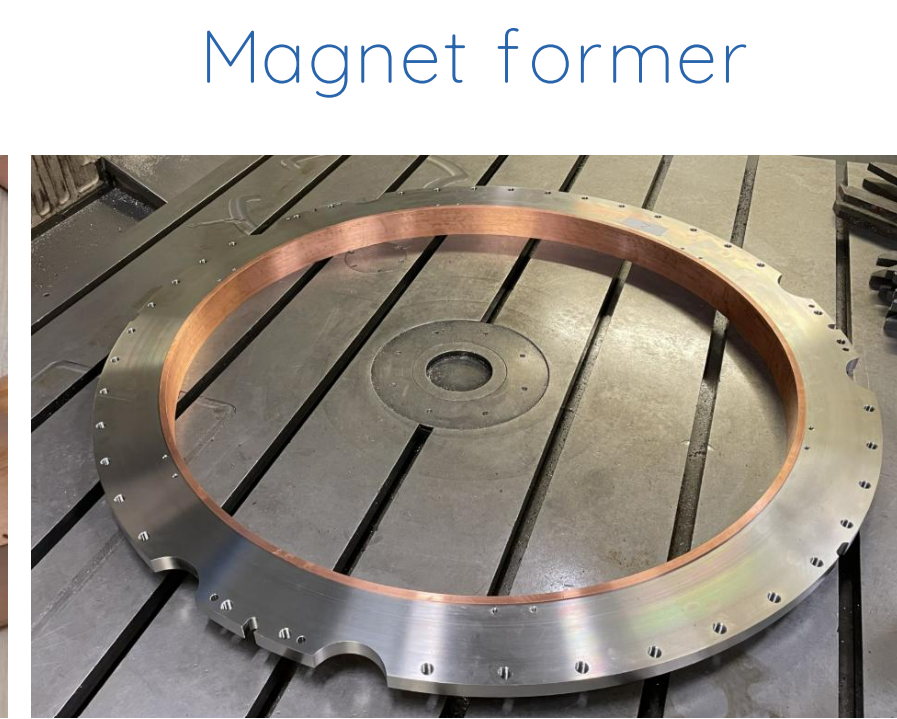
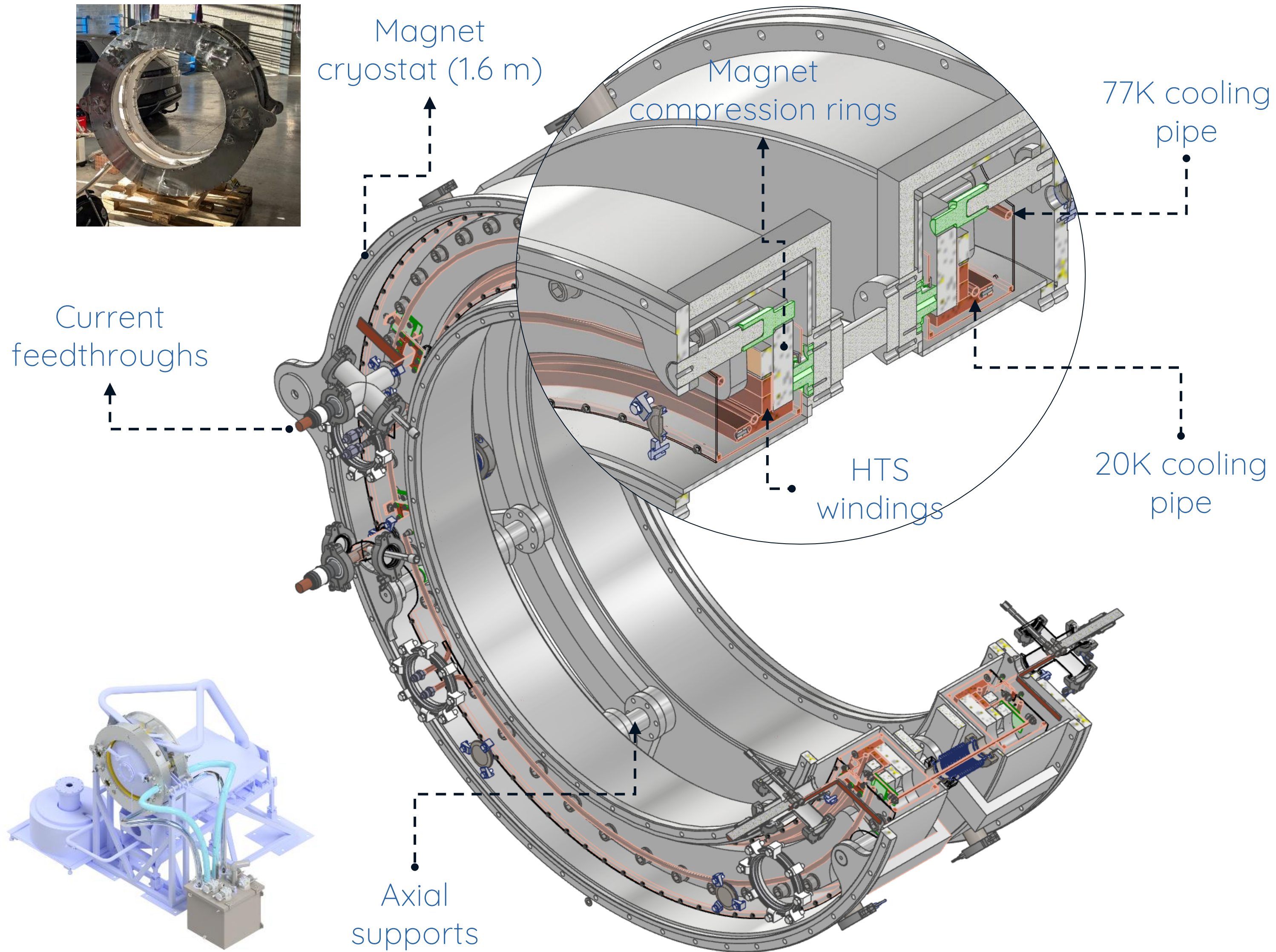

Fitting of magnet former within cryostat and thermal screens





On track for full scale demonstration of suspended molten metal flow up to 850°C within high field environment

→ Stay tuned !!

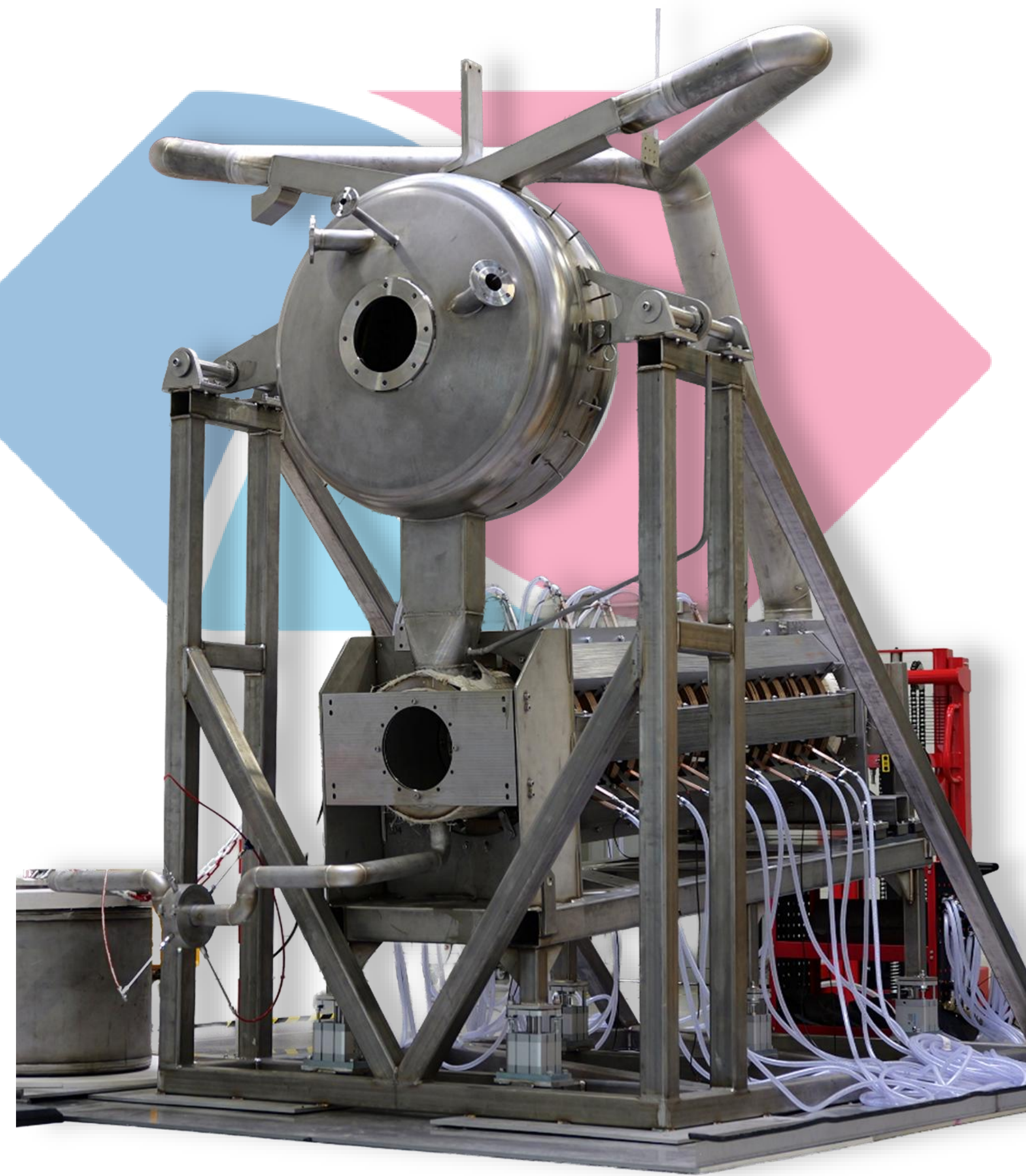
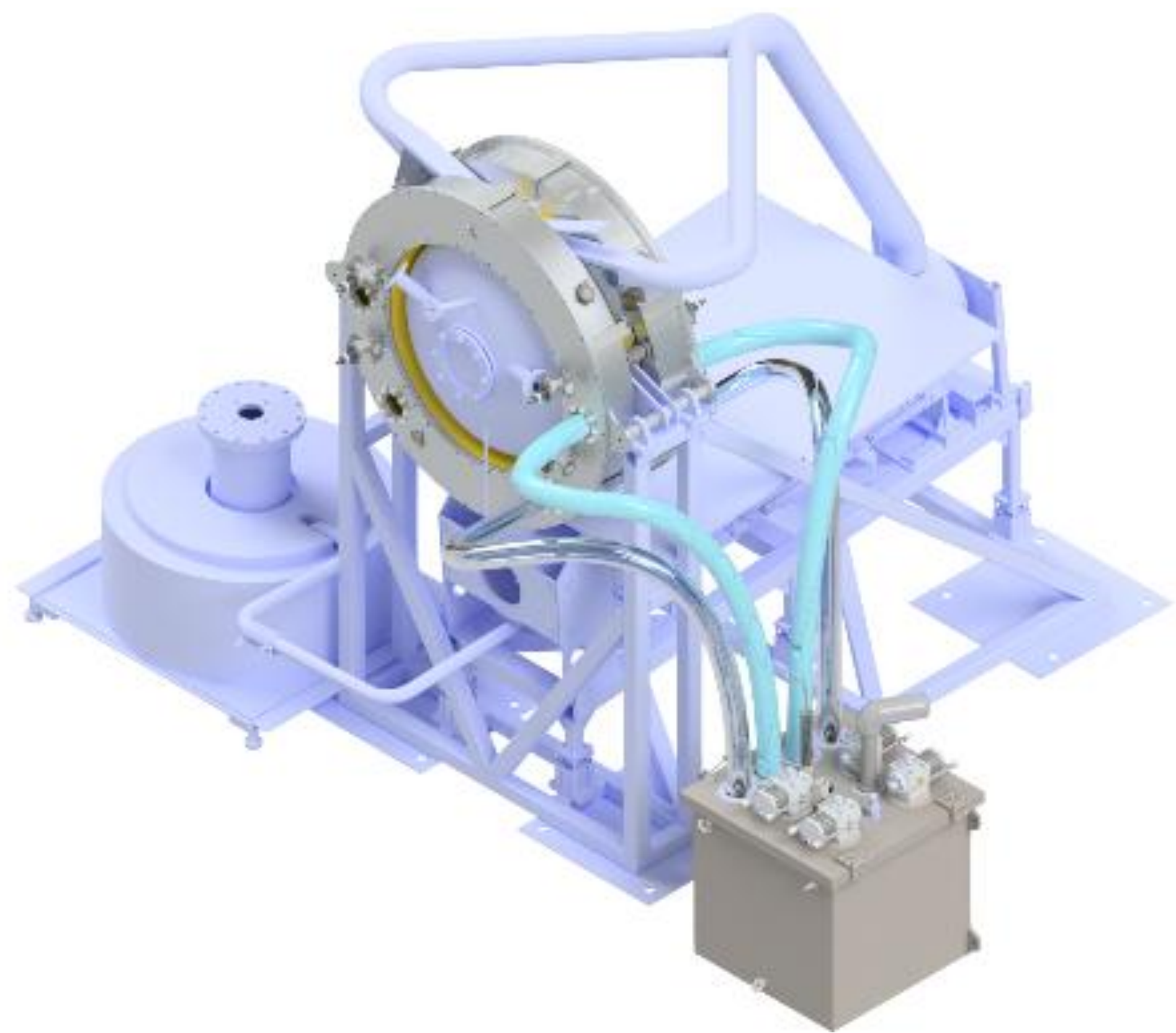



RENAISSANCE
FUSION

Want to learn more?

victor.prost@renfusion.eu | [FAQs renfusion.eu/faq](https://renfusion.eu/faq) | [YouTube video](#)

renfusion.eu