

Next Generation Drive Train

Superconductivity for Large-Scale Wind Turbines*

Applied Superconductivity Conference, Portland, Oregon
October 11th, 2012

R. Fair, W. Stautner, M. Douglass, R. Rajput-Ghoshal, M. Moscinski, P. Riley,
D. Wagner, J. Kim, S. Hou, F. Lopez, K. Haran, J. Bray, T. Laskaris, J. Rochford
General Electric - Global Research, Niskayuna, NY, USA

R. Duckworth
Oak Ridge National Laboratory, Oak Ridge, TN, USA.

** This material is based on work supported by the Department of Energy under Award Number DE-EE0005143.
Acknowledgements are also due to The Oak Ridge National Laboratory for their contribution to this project.*

Project Objectives

The primary objective of the project was to apply low temperature superconducting technology to the design of a direct-drive wind turbine generator at the 10MW power level in order to reduce the Cost of Energy (COE).

The 6 month project focused on the design of the generator, an evaluation of the commercial viability of the design together with an identification of high risk components.

How can we get to a commercially viable product as quickly and as pragmatically as possible ?

- ❑ Use readily available, cost-effective proven superconductor
→ LTS
- ❑ Reduce risk at the pre-design stage → e.g. eliminate the cryogen transfer coupling
- ❑ Stationary field → Utilize GE Healthcare MRI cooling technology know-how
- ❑ Utilize conventional manufacturing materials and existing production processes
- ❑ Utilize GE's extensive knowledge of wind system integration

Project Scope

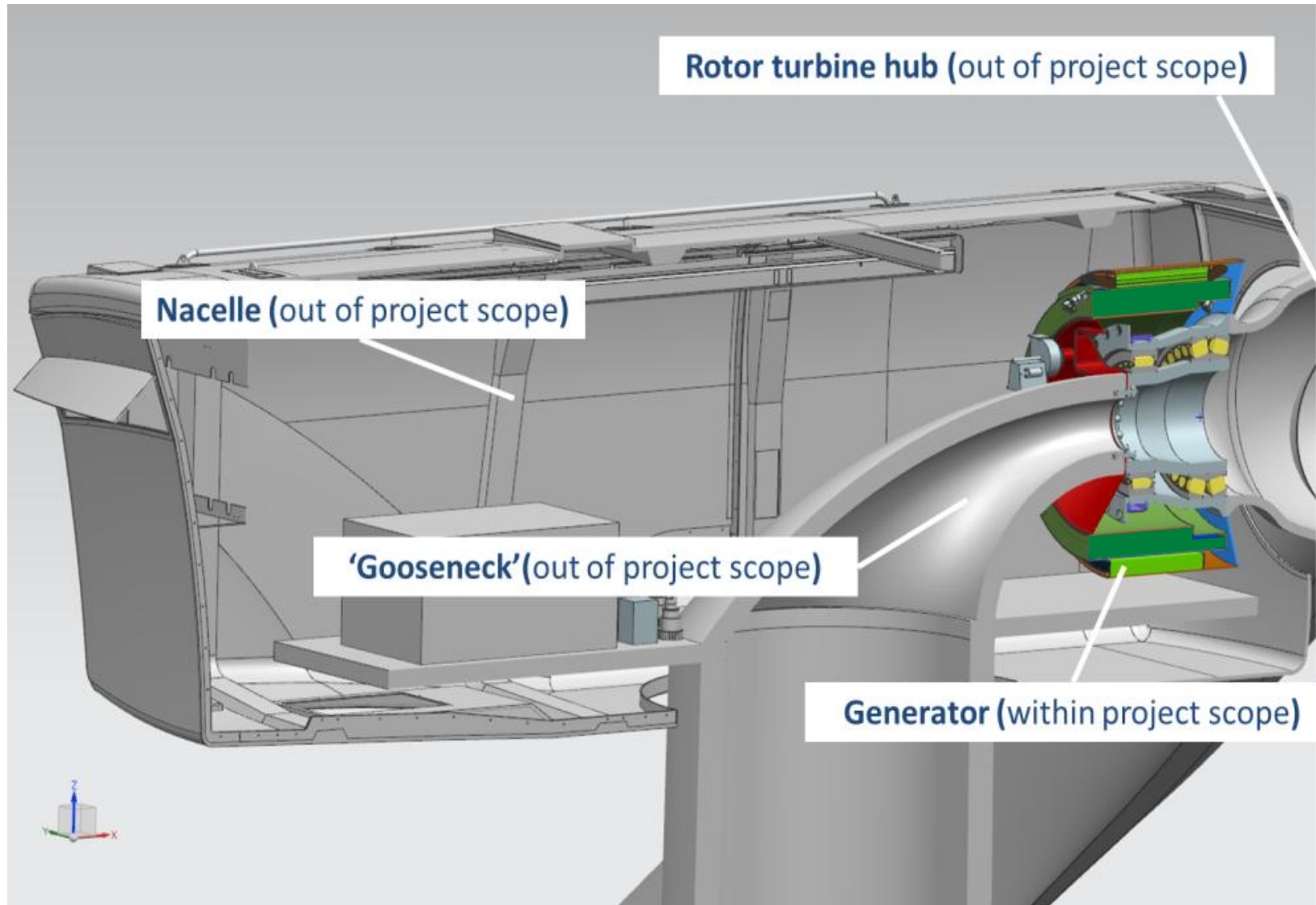

Generator external view

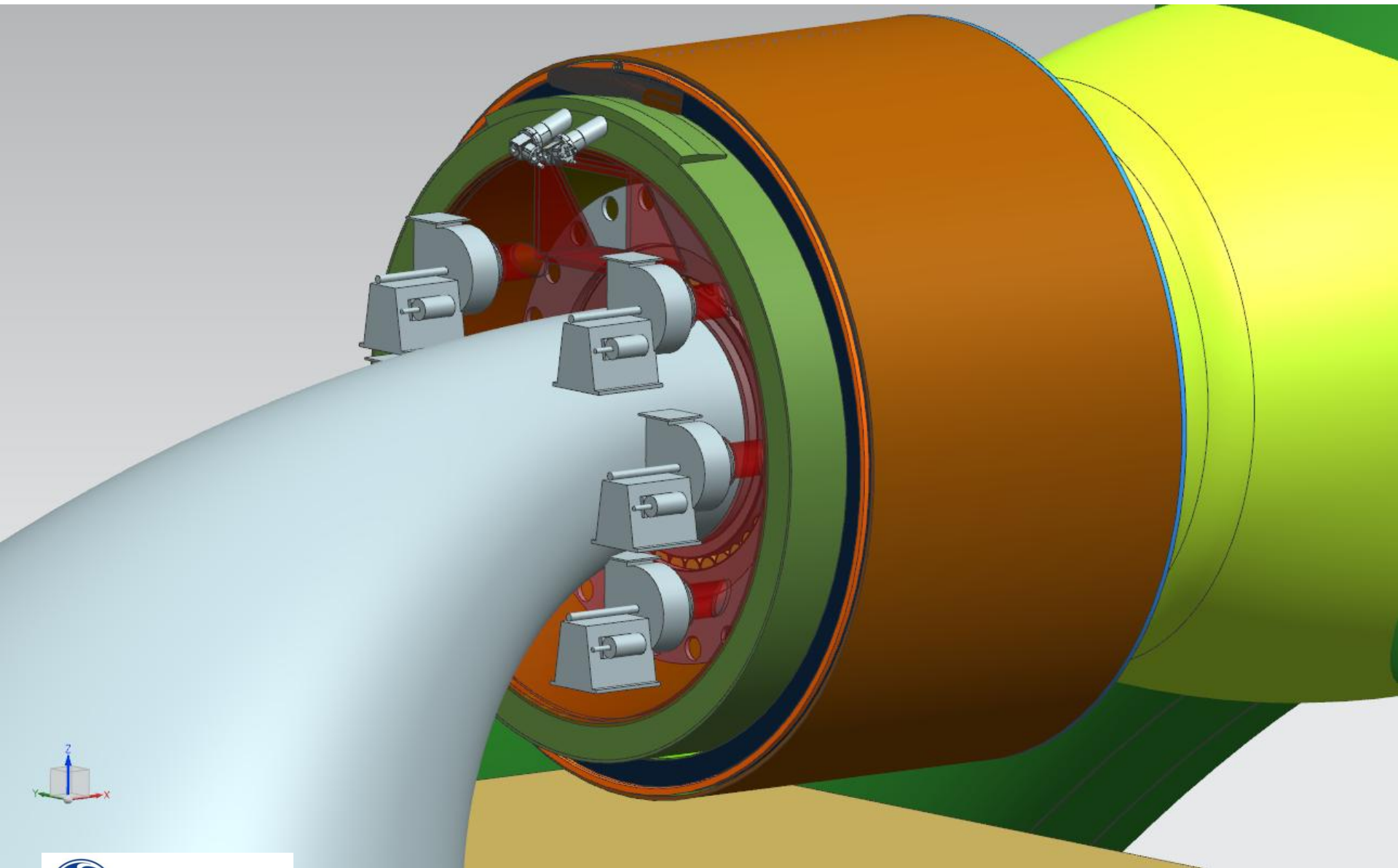

Key Generator Dimensions

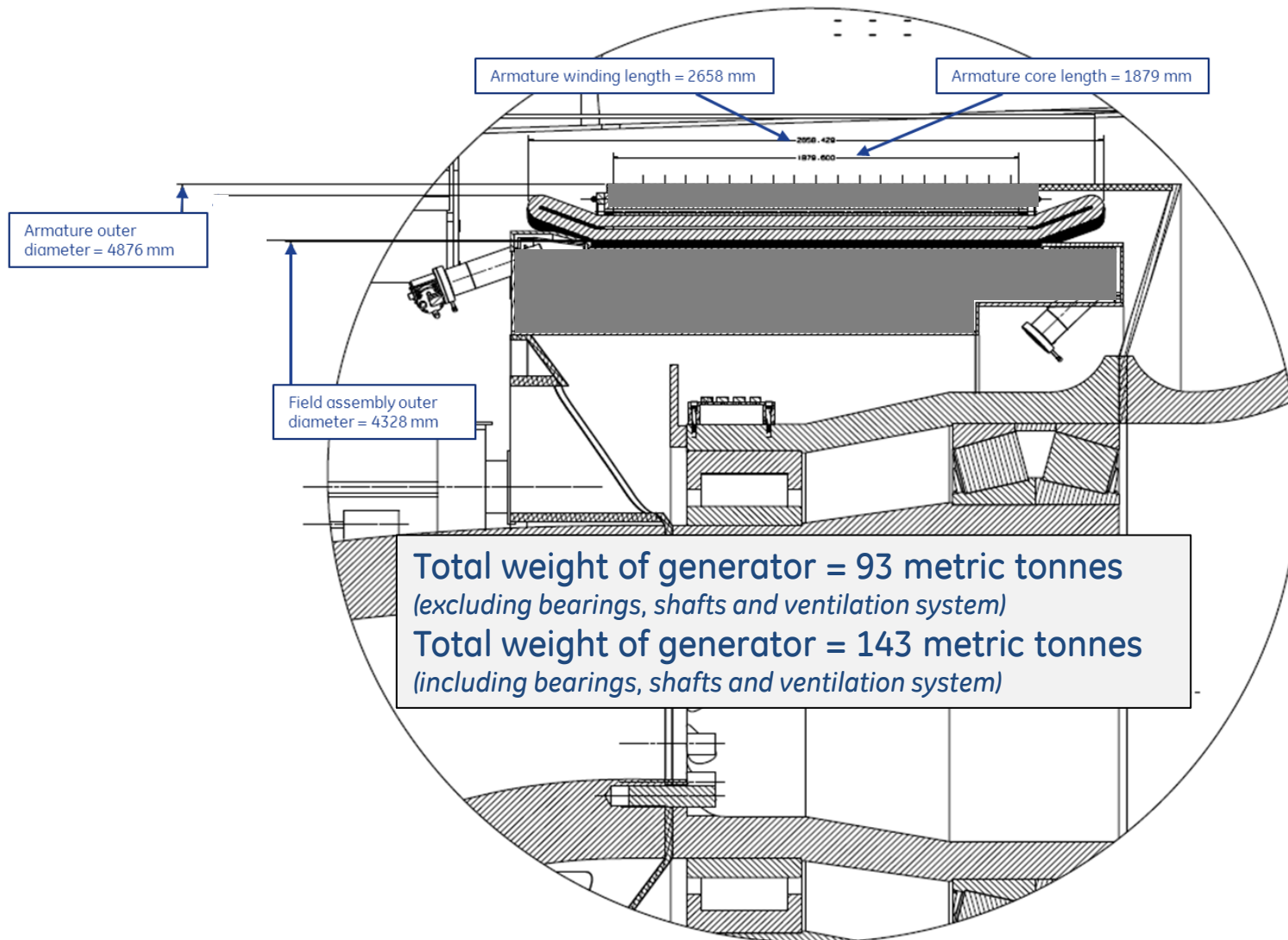

Cross-sectional view of the generator

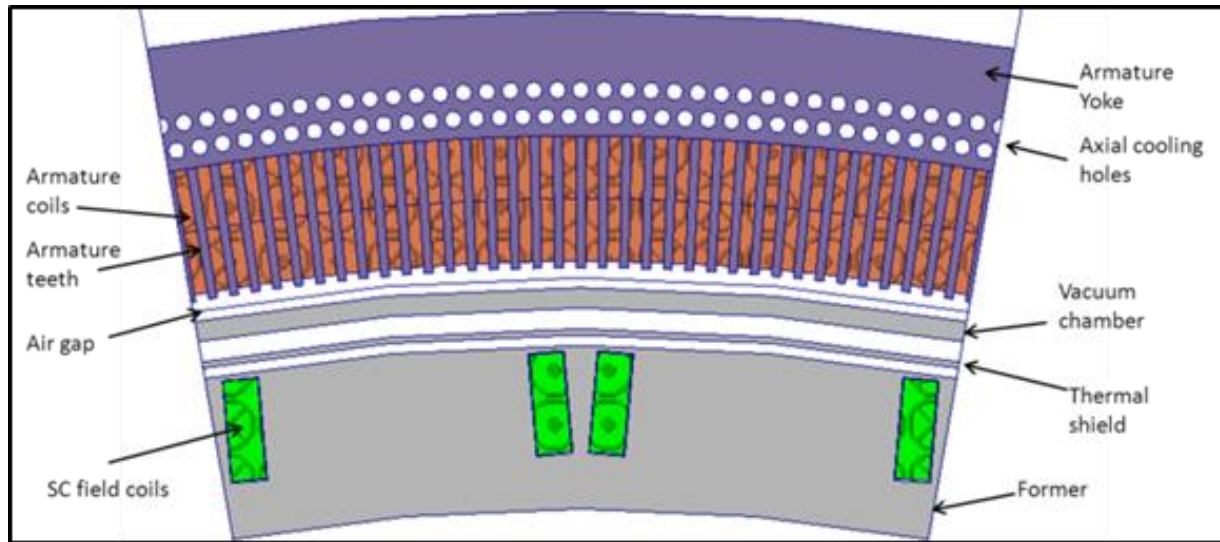

Open circuit flux density plot (Tesla)

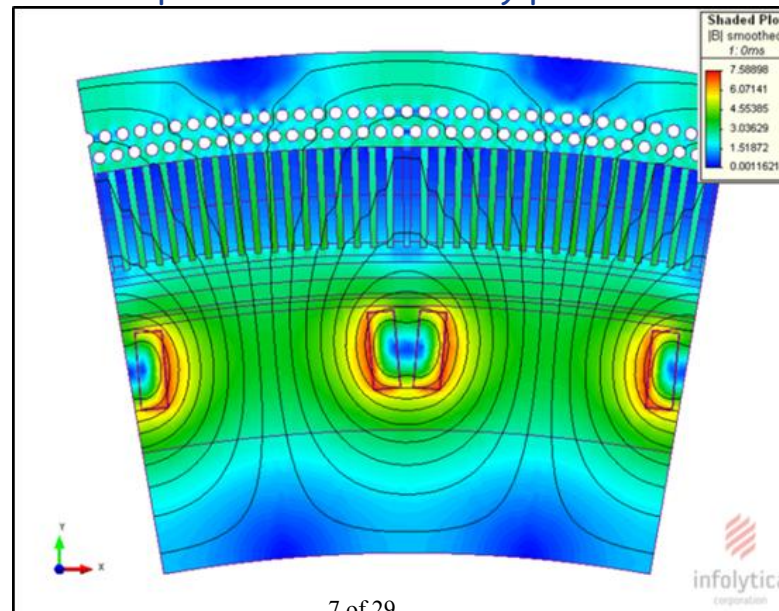

Generator final design parameters

Parameter	Value
Rated Power	10 MW
Rated Speed	10 rpm
Rated torque	10 MNm
Rated Voltage	3300 V line-line
Rated Current	1750 A
Rated Power Factor	1.0
Full Load Efficiency	95-96%
Physical Air gap length	19 mm
No. of poles / No. of slots	36 / 648
Armature Winding Type	3 phase, 2 layer, lap, form wound
Insulation	Class F (with Class B temperature rise)
SC Field MMF	928000 AT/pole
Armature Cooling	Axial air cooled thru air gap and yoke

Figure of Merit	10 MW SC Generator	Conventional PM Generator	Increase with SC
Shear Stress	179 kPa	85 kPa	2X
Torque Density (EM only)	197 Nm/kg	94 Nm/kg	2X
Torque Density (Drivetrain)	92 Nm/kg	44 Nm/kg	2X
Peak Fault Current	15 p.u. (L-L-L)	4 p.u.	4X
Peak Fault Torque	12 p.u. (L-L)	2 p.u.	6X

Generator losses and efficiency

Generator Load Condition 10MW @ 10rpm	
Arm winding DC Loss	363 kW
Armature AC Loss	56 kW
Armature Yoke Loss	5.7 kW
Armature Teeth Loss	5.6 kW
Armature Core Clamp Loss	2.1 kW
Field AC Loss (incl. vessels)	2.6 kW
Armature Slip Ring Loss	4.6 kW
Friction and Windage	negligible
Cryocooler power (3)	22.5 kW
Cooling Air Blowers (6)	39 kW
Total Loss	501 kW
Efficiency	95.0%

Armature slip ring design

Based on GE-Hydro design and operational experience with 3 phase, 3500A, 17kV, 100MW slip ring/collector systems.

Performance factor for previous installation after 3 years of commercial operation (2008) :

$$PF = \frac{\sum MW.h (Actual)}{MW.h (Scheduled)} = 99.7\%$$

(equivalent of 3.28 days outage out of a total of 1095 days)

Current Design:

- No. of slip rings = 4
- Slip ring OD = 3m
- No. of carbon brushes per slip ring = 30
- Current per brush = 60A
- Rotational speed = 10rpm
- Total operational loss @ 10MW = 4.6kW
- Air-cooled assembly
- Brush wear per year < 2 mm @ 10rpm

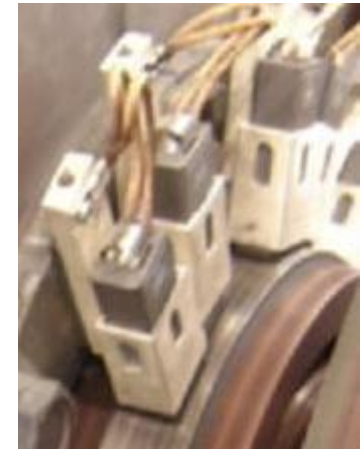
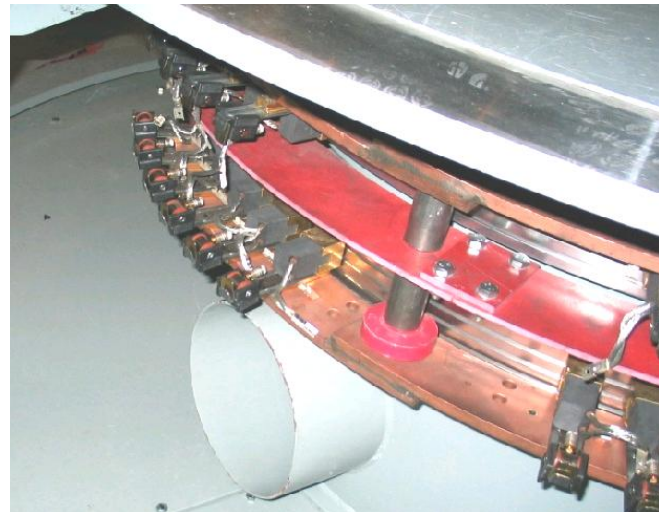

Generator cooling configuration

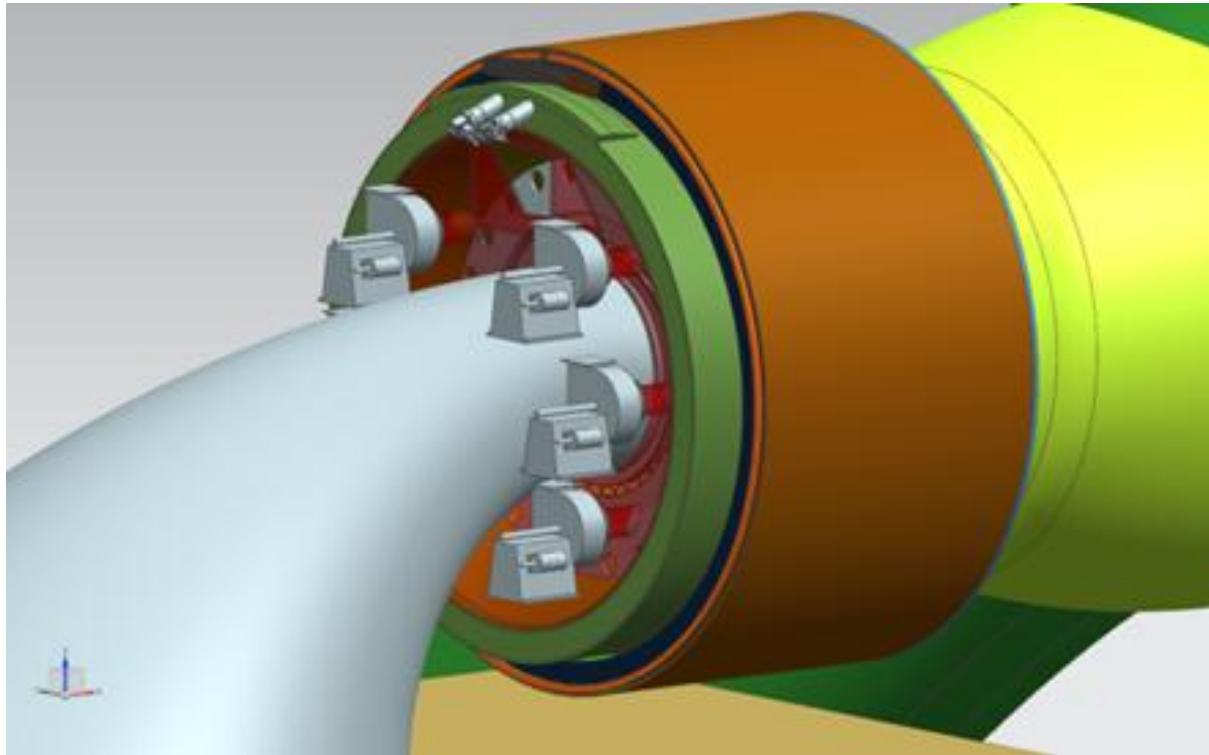

- Six air blowers are mounted to the field support plate.
- They are belt driven units with 5hp ,3600 rpm, 460 v, 3 ph, 60 Hz motors, housing drains, motor covers, shaft seal, belts and drives.
- The weight of each unit with aluminum wheel, housing and motor pedestal is approximately 251 lbs. The estimated input power for six blowers is ~39kW.

Magnetic vs Non-magnetic armature teeth

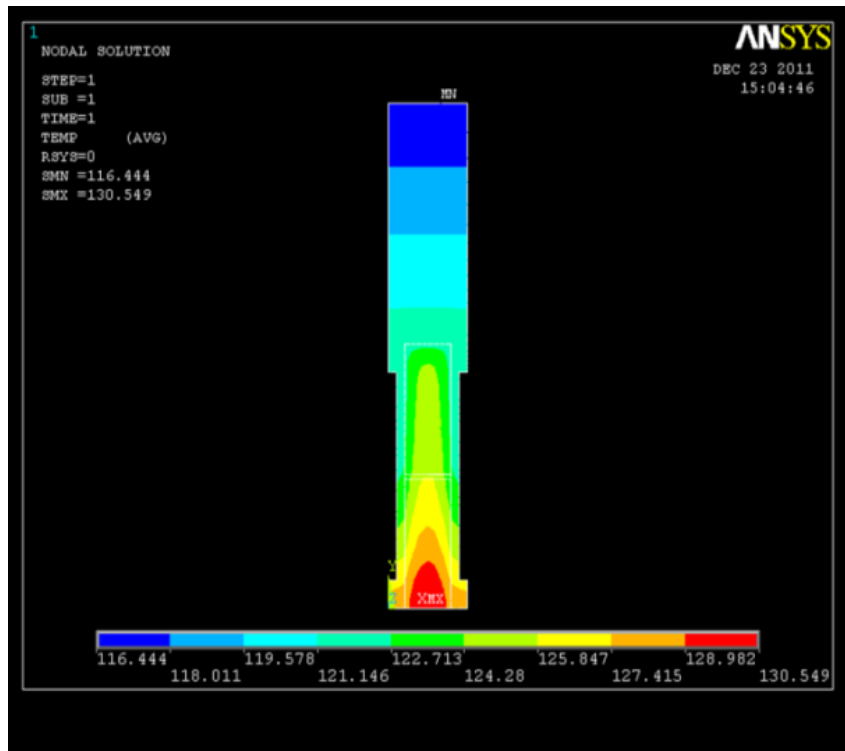

Magnetic teeth

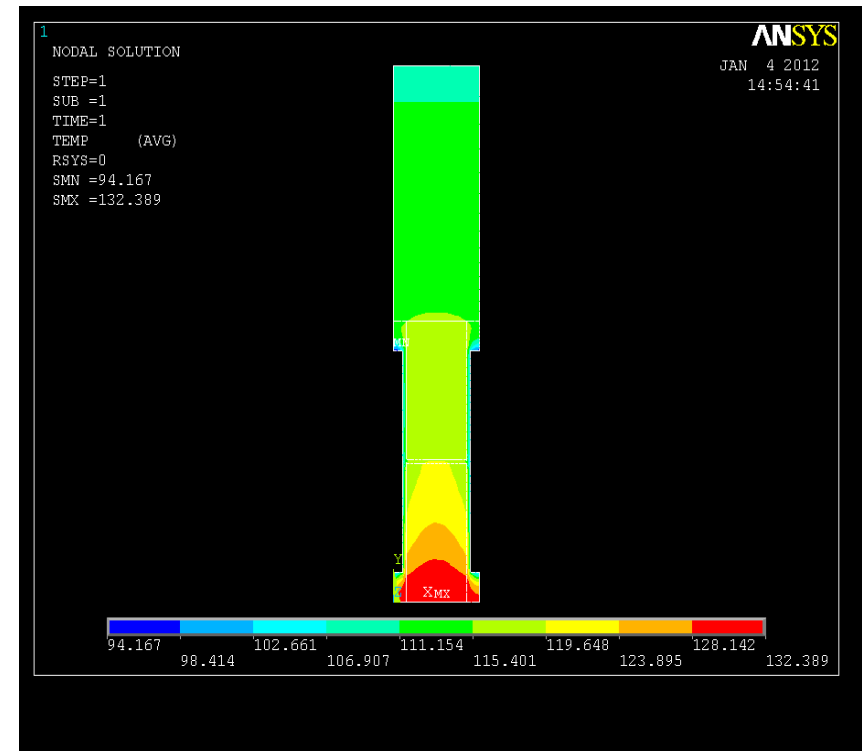

Non-magnetic teeth

- Hot spots in the armature and vacuum chamber wall for magnetic teeth are slightly lower than for the non-magnetic teeth design option
- Hot spot temperature of the vacuum wall is well below the thermal radiation limit of 80°C

Armature cooling duct design

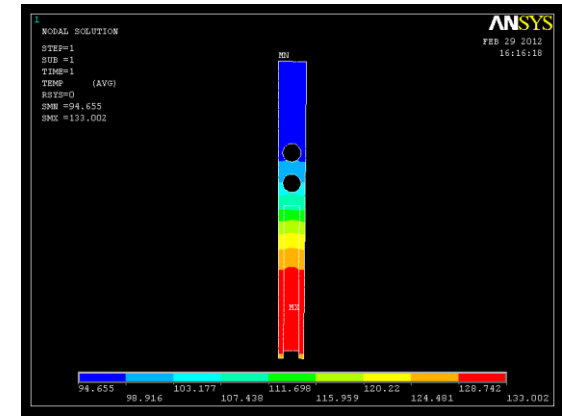
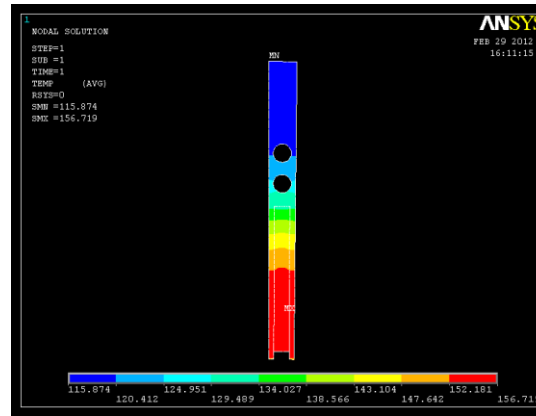
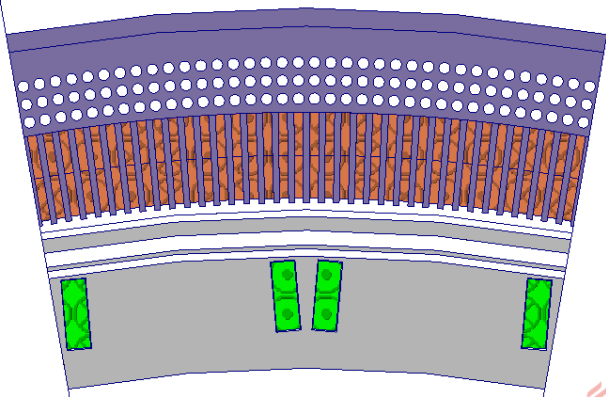

# of working blowers	Armature hotspot
6	133.0 °C
5	145.7 °C
4	157.2 °C

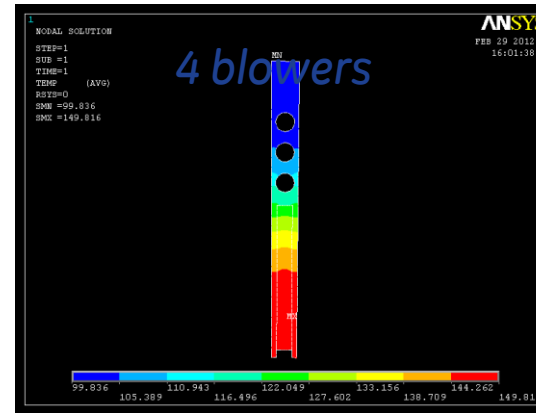

4 blowers

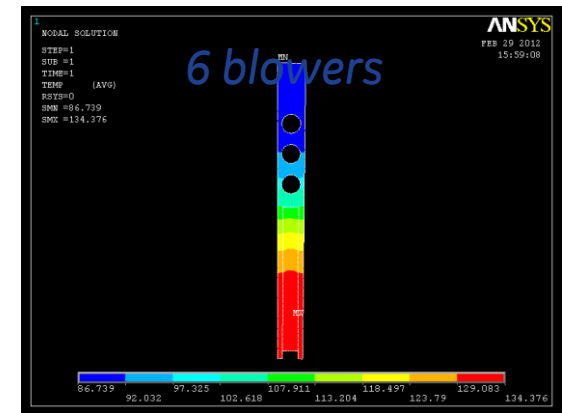

5 blowers

→ The final design for the cooling of the armature settled upon 2 rows of cooling holes with a total of 6 air-blowers providing a more uniform air flow distribution and a measure of redundancy

SC coil optimization

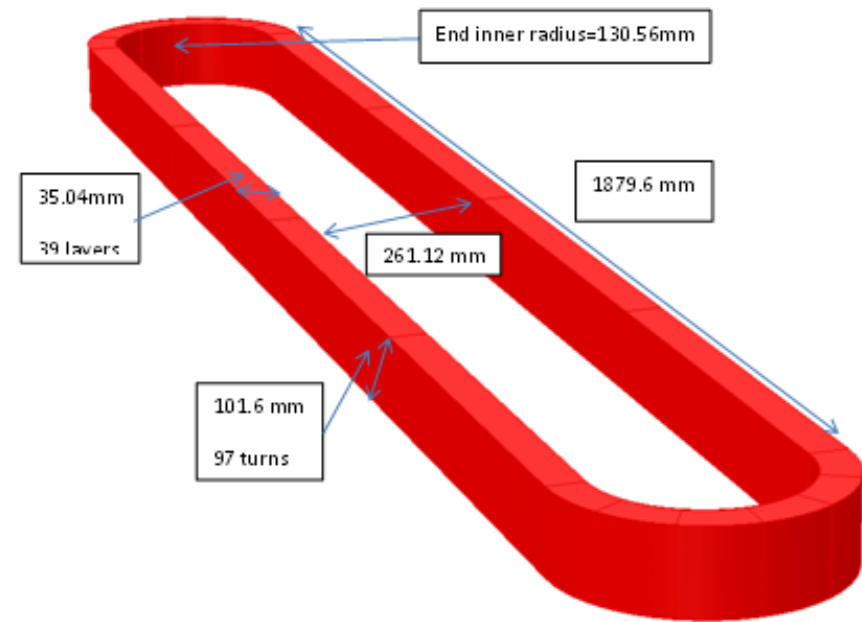
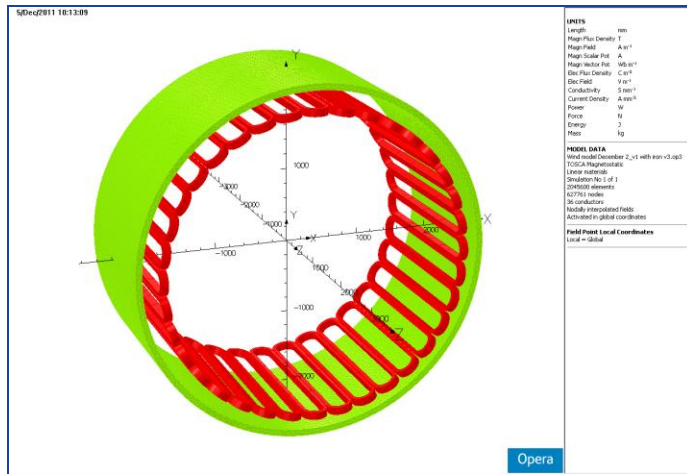

- Optimization parameters

- Width of the coil
- Height of the coil
- End radius of the coil
- Operating current in the coil
- Short sample percentage for coils
- Current sharing temperature for the conductor
 - A sufficient margin is required for the stable operation of the coils. Current sharing temperature depends on the maximum field in the coil, critical current at maximum field, ratio of operating current to critical current at maximum field and ratio of maximum field in the coil to critical field of the conductor

SC coil final design parameters

Parameter	Value
Coil type	Racetrack
Coil width (mm)	35.00
No. of layers in coil width	39
Coil height (mm)	101.60
No. of turns in coil height	97
Coil length straight (mm)	1879.60
Coil Inner Width (mm)	261.01
End radius (mm)	124.58
Type of conductor used	Cu-(NbTi)
Bare diameter of conductor (mm)	1.00
Insulated diameter of conductor (mm)	1.05
Operating current (Amp)	276.86
Total ampere turns (A)	928000
Maximum field in the coil (T)	7.35
Critical current at the maximum field (Amp)	466.75
Short sample percentage (%)	59.96
Critical temperature (K)	6.08
Stored energy of the system (MJ)	40.6
Inductance of all the coils (H)	1059
Total conductor used for 36coils (km)	720
Total estimated weight of the coils (kg)	3840



Parameter	Value
Type of conductor used	Cu-(NbTi)
Cu:SC	1.5
Bare diameter of conductor (mm)	1.00
Insulated diameter of conductor (mm)	1.05
Number of filaments	7400
Filament diameter (micron)	7.5

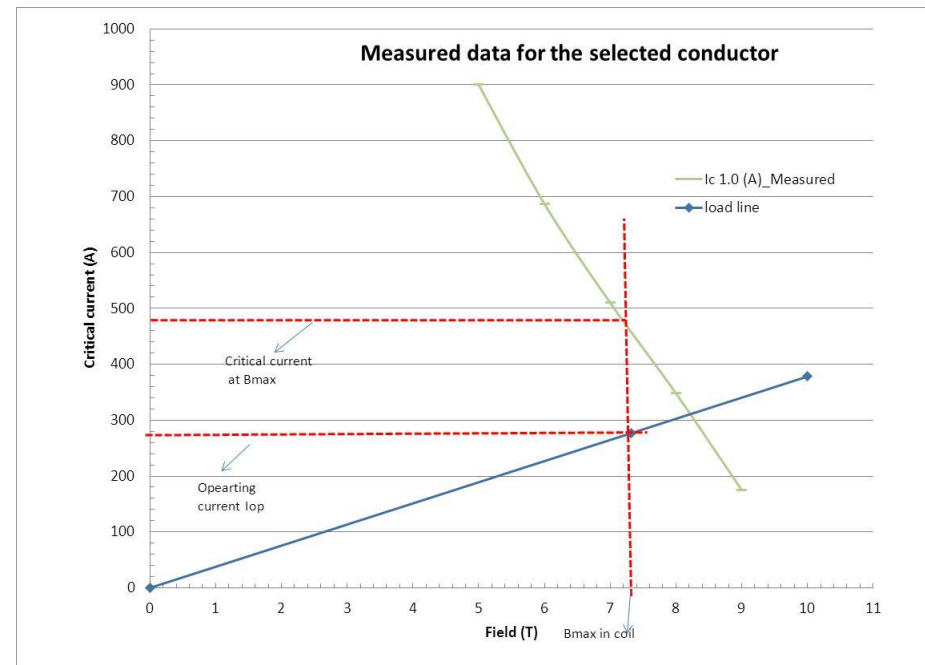

AC Losses

Loss Contribution

1. Loss during operation

- a. Losses due to field current boost
- b. Losses due to external time varying fields
- c. Losses due to field current change

2. Loss during ramping

- (i) Eddy Current loss
- (ii) Hysteresis loss
- (iii) Penetration loss

- Total heat loads are as follows:
 - Total heat load for single sweep= 0.17 W
 - Total heat load during operation= 0.64 W
- An Independent AC loss calculation has been performed by Dr. Robert Duckworth at the Oak Ridge National Laboratory (ORNL), based on the same assumptions provided above.
 - Total heat load for single sweep= 0.32 W
 - Total heat load during operation= 0.80 W

→ The final values of the losses are different and will need to be addressed via tests.

Monitoring and diagnostics

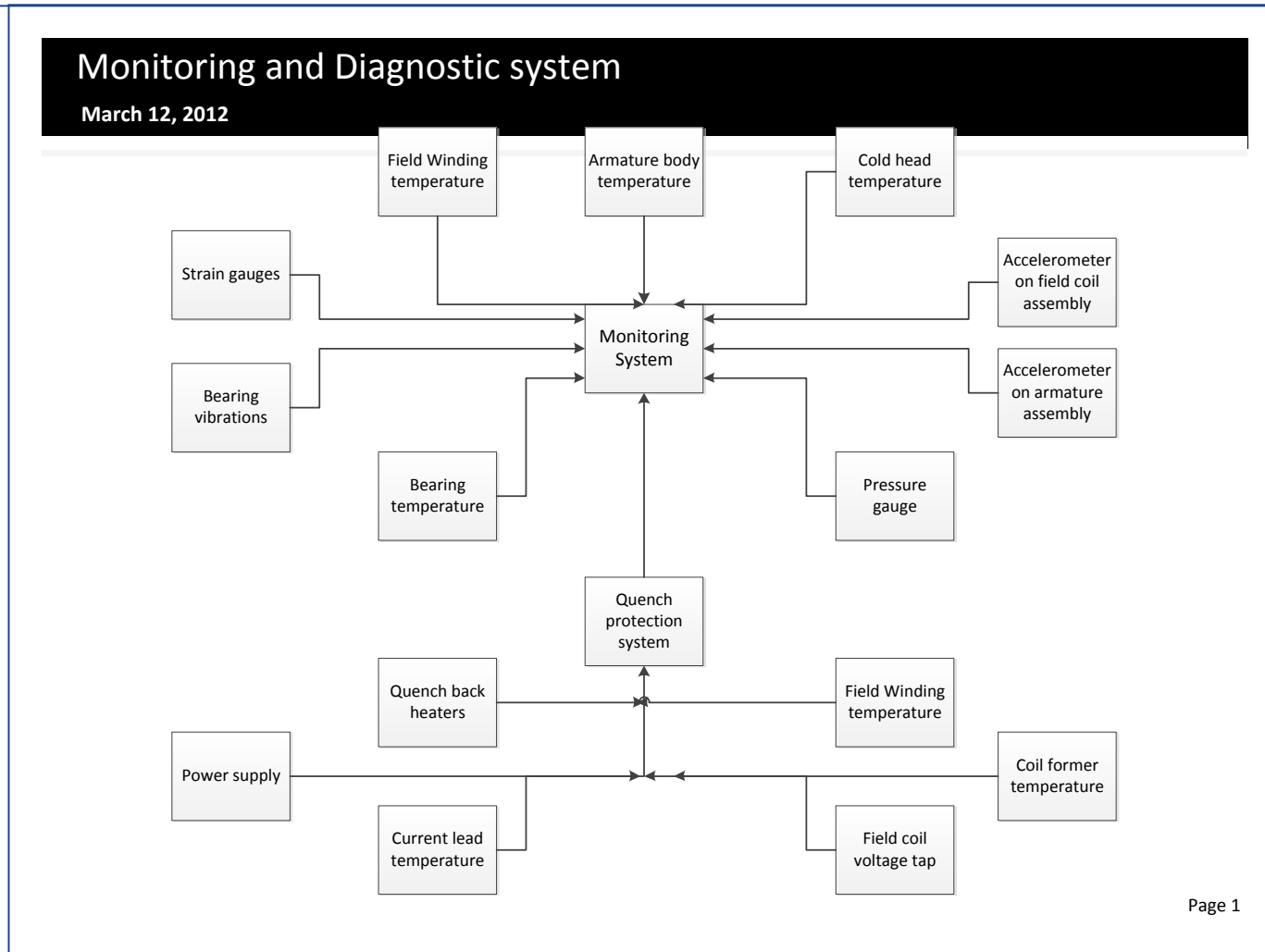

→ Remote monitoring and diagnostics systems will play an extremely important role for these systems

Quench Analysis – 5 Coil Model

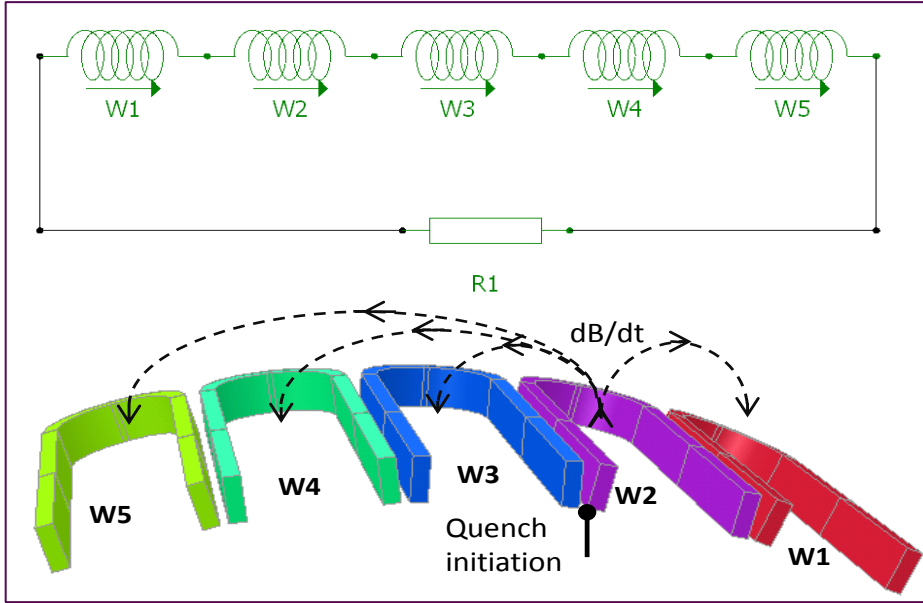

→ Coupling losses play a crucial role in the quench propagation process

→ Major portion of energy dissipated in the coil where quench initiated

→ Important factor in defining quench protection method

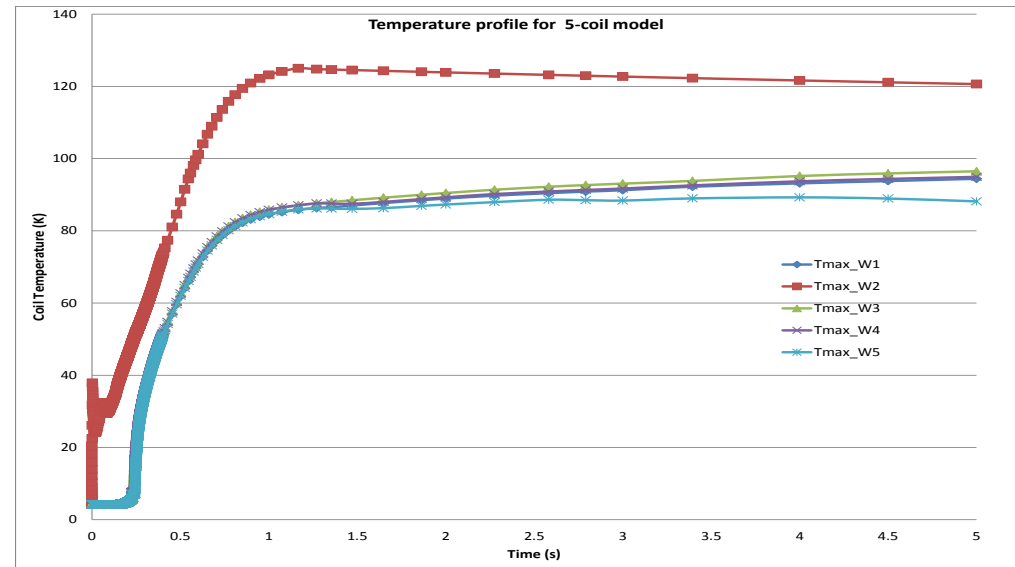

Cryogenic closed-loop cooling concept

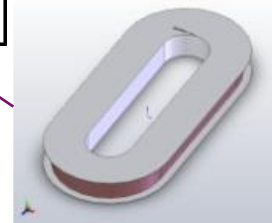
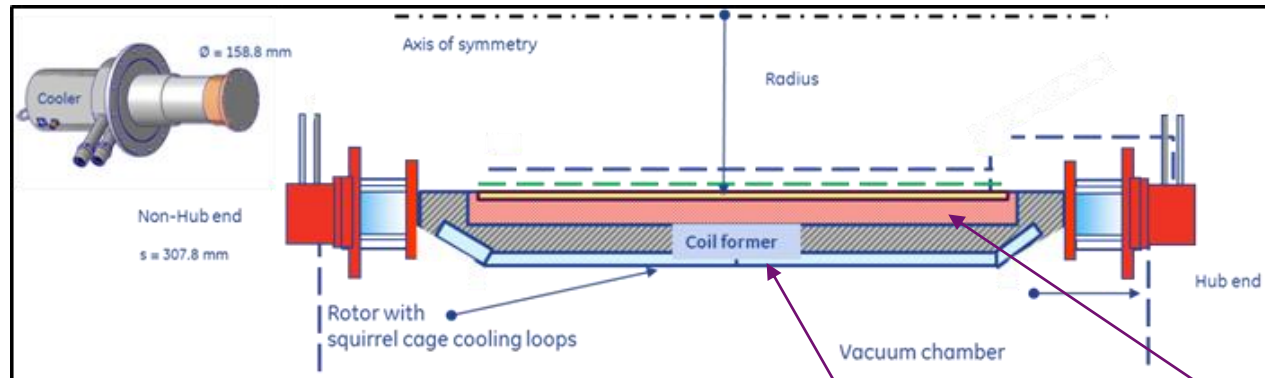

Racetrack coil

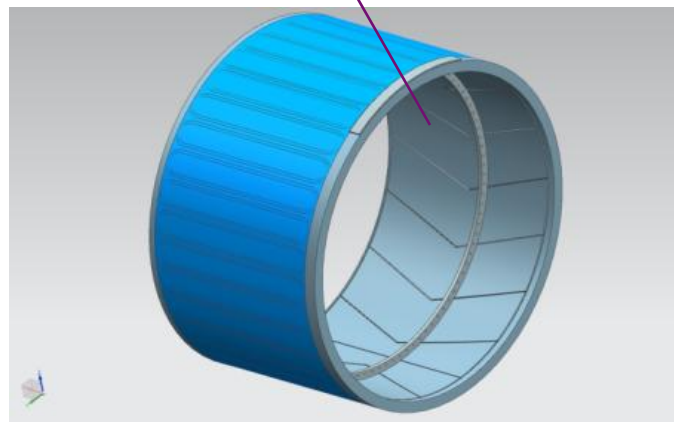
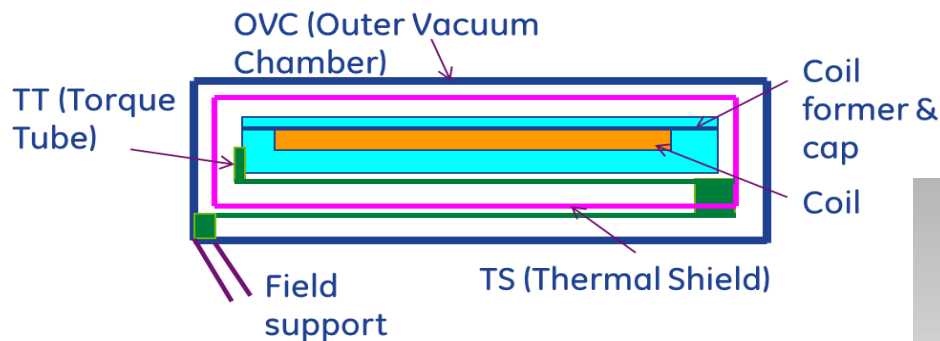

Coil former cooling tubes

Heat loads

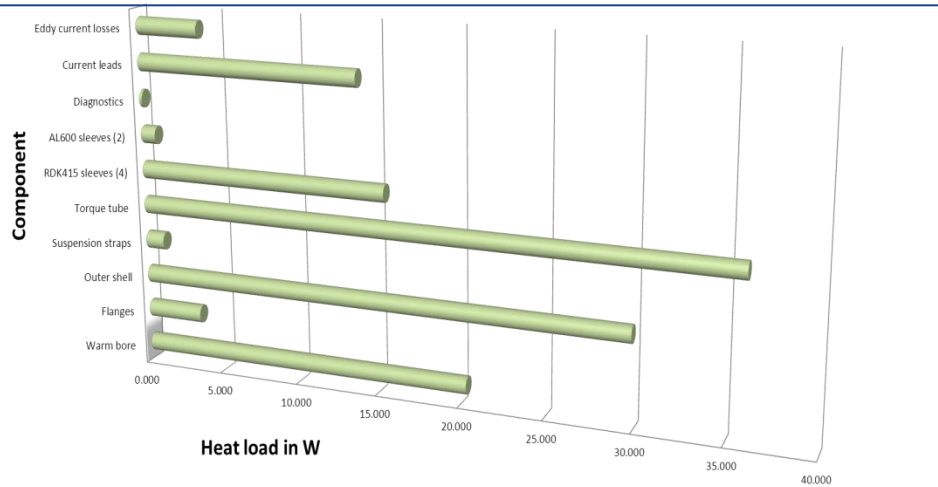

Component	Warm bore	Flanges	Outer shell	Suspension straps	Torque tube	RDK415 sleeves (4)	AL600 sleeves (2)	Diagnostics	Current leads	Eddy current losses
Series2	20.380	3.515	29.869	1.235	36.000	15.500	1.000	0.250	13.900	4.000

Field winding assembly, thermal burden analysis

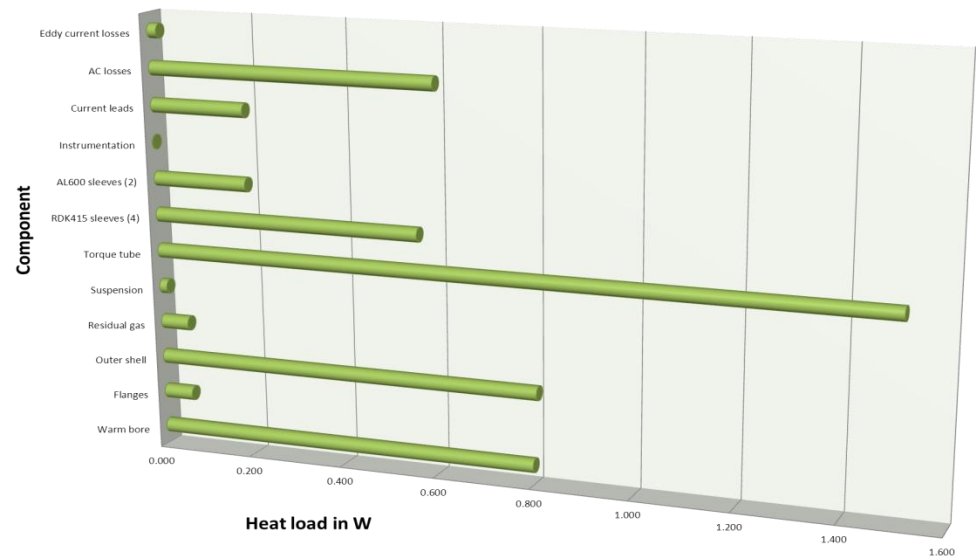

Component	Warm bore	Flanges	Outer shell	Residual gas	Suspension	Torque tube	RDK415 sleeves (4)	AL600 sleeves (2)	Instrumentation	Current leads	AC losses	Eddy current losses
Series1	0.800	0.063	0.807	0.060	0.016	1.510	0.563	0.200	0.002	0.200	0.600	0.020

Generator mechanical sub-systems

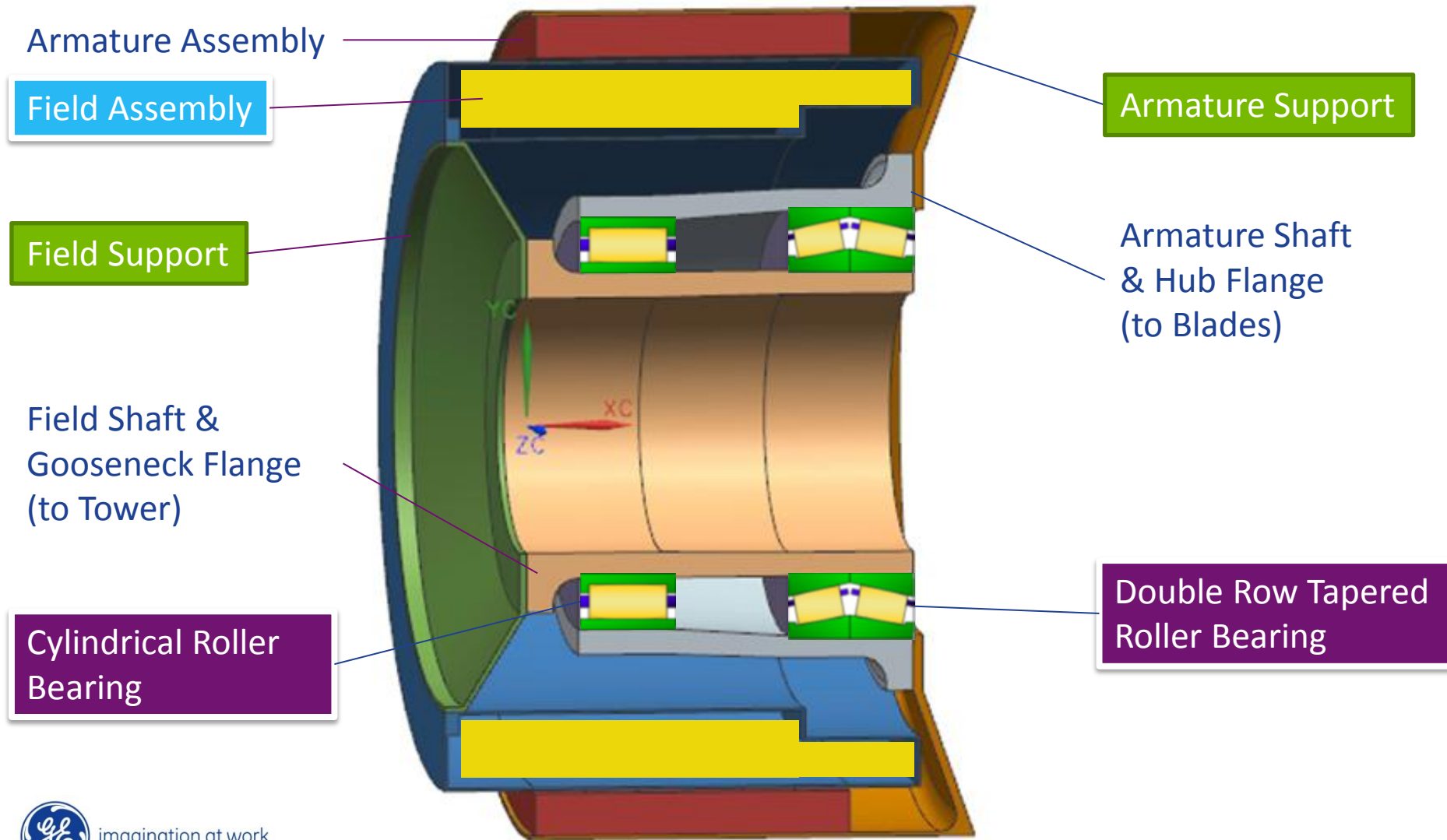

Supporting structure analysis

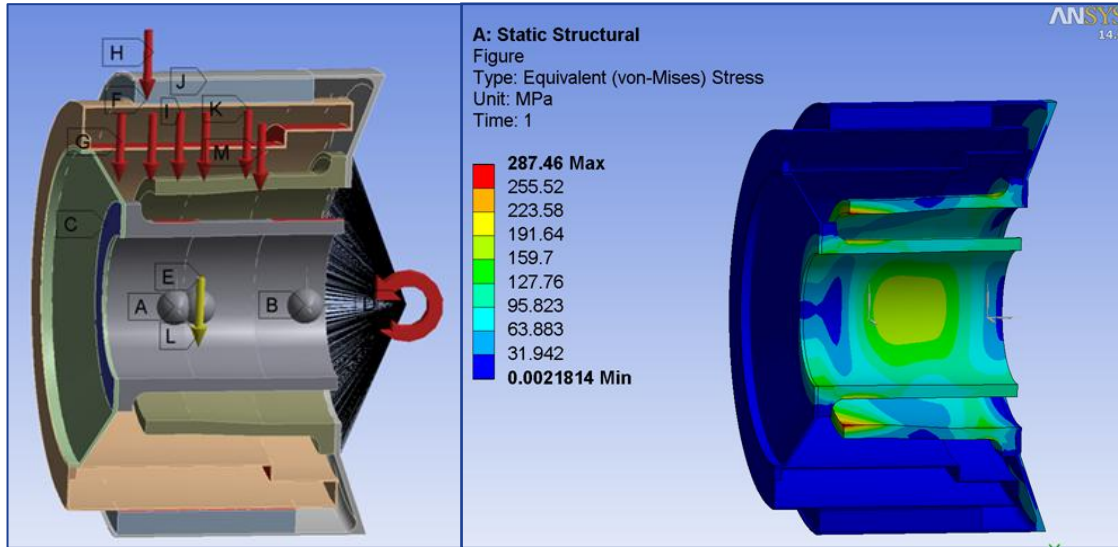

- Standard Gravity
- Wind Load (Nodding Moment)
 - Nominal = $5.8e9$ N-mm
 - Extreme = $5.1e10$ N-mm
- EM Load
 - Nominal = 160 psi
 - Deflection Load = $5.4e6$ N/in

Bearing design summary

- Industry proven configuration
- Sized against wind extreme loads using Wind Turbine Design Tools
- Bearing Stiffness calculated using Bearing Design Tools
- 25+ years life estimation

Loads	Air Gap Closedown Spec	Air Gap Actual Closedown	Max Stress (MPa)	Safety Factor
Nominal	-	12%	37	10.3
Extreme	< 50 %	41%	287	1.3

Field assembly torque tube design

The torque tube has to meet several key design constraints:

- extreme torque load conditions with respect to buckling
- exceptional fatigue properties, and in particular at low temperatures
- light weight, ease of manufacture
- minimal heat burden to magnet coil former with respect to thermal conductivity
- minimal thermal radiation
- minimum of optically black cavities or so-called “black holes”
- simple and uncompromised application of MLI should be possible

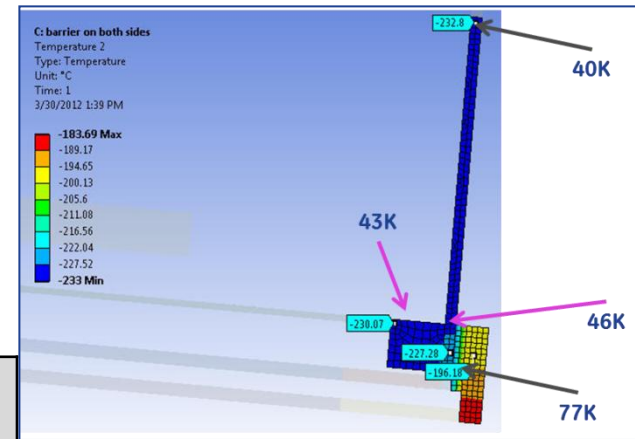
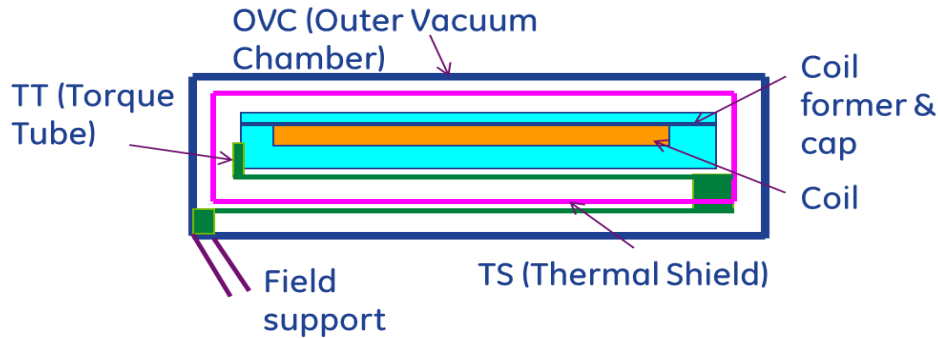

Thermal barrier concept

	Material	Working temperature (K)	Tensile Strength, Yield (Mpa)*	Max Stress (MPa)	Max Stress SF	Max Radial displacement (mm)	Max Rotational displacement (mm)
OVC	6061-T6	40-300	288	30	9.6	0.03	0.04
TS	1100	40-60	63	10	6.3	1.22	15.25
Upper TT	TiAl6V4	4-40	1132	390	2.9	1.63	20.98
Lower TT	TiAl6V4	40-300	1926	338	5.7	0.94	14.01
Coil former	A356-T61	4	330	78	4.2	2.54	23.70
Coils	NbTi composite	4	190	34	5.6	2.51	23.60

LTSC generator COE

Drivetrain Capex

- LTSC Generator allows...
 - Increasing turbine size to 10MW with reducing drivetrain cost (\$/kW) by 30% over PMDD, 38% over Geared, 28% over HTSCG
 - PMDD cost based on 2010 Maples et al. (NREL/TP-5000-49086), which assumes 2010 rare-earth material prices. Actual PMDD generator costs much higher today.

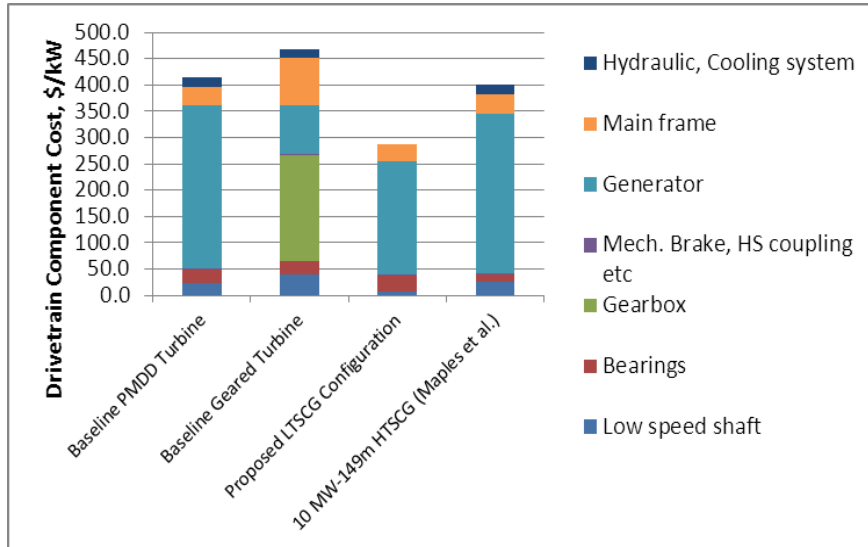

Cost of Energy

- Baseline is 5MW-126m
- Proposed LTSC Gen is 10MW-160m
- COE Reduction
 - 13% reduction from PMDD, potentially higher due to increased PMDD cost in last 2 years, further potential to reduce SC wire cost
 - 18% reduction over geared

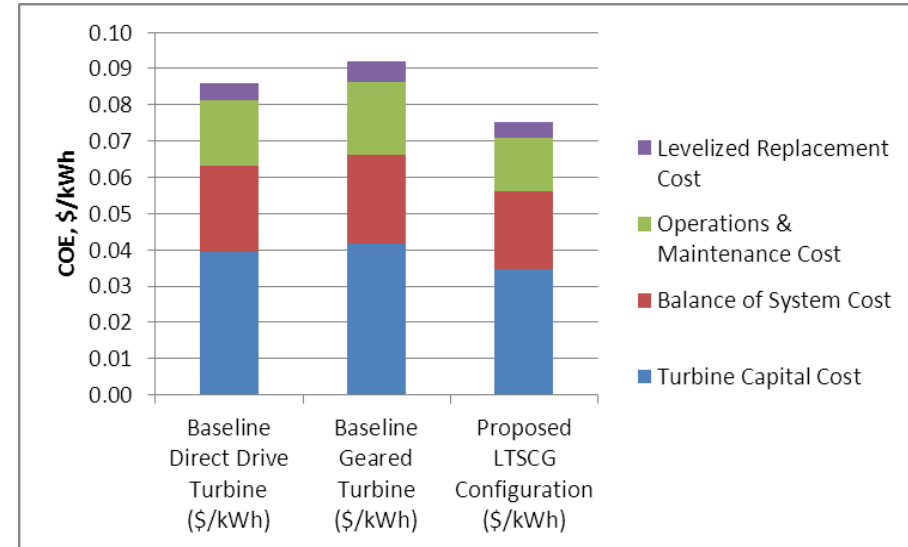

Component risk identification

**Segregation of risks by component
(After risk mitigation)**

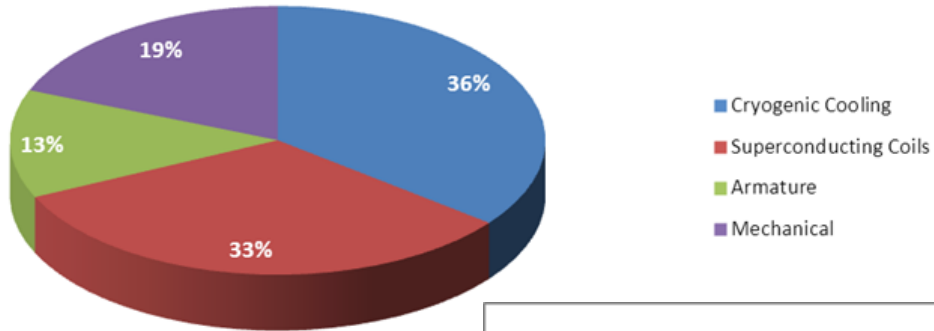

Cumulative Risk Priority Numbers (RPN)

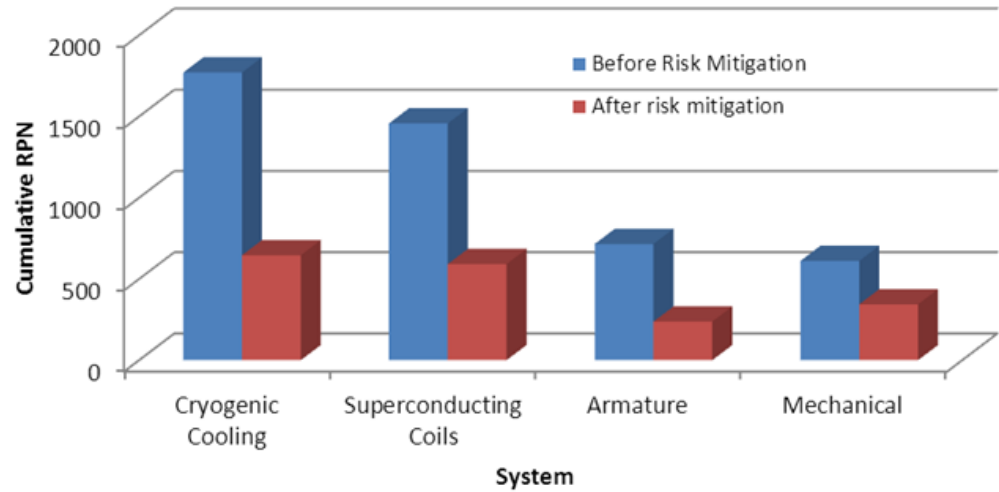

Technology Readiness Level Analysis

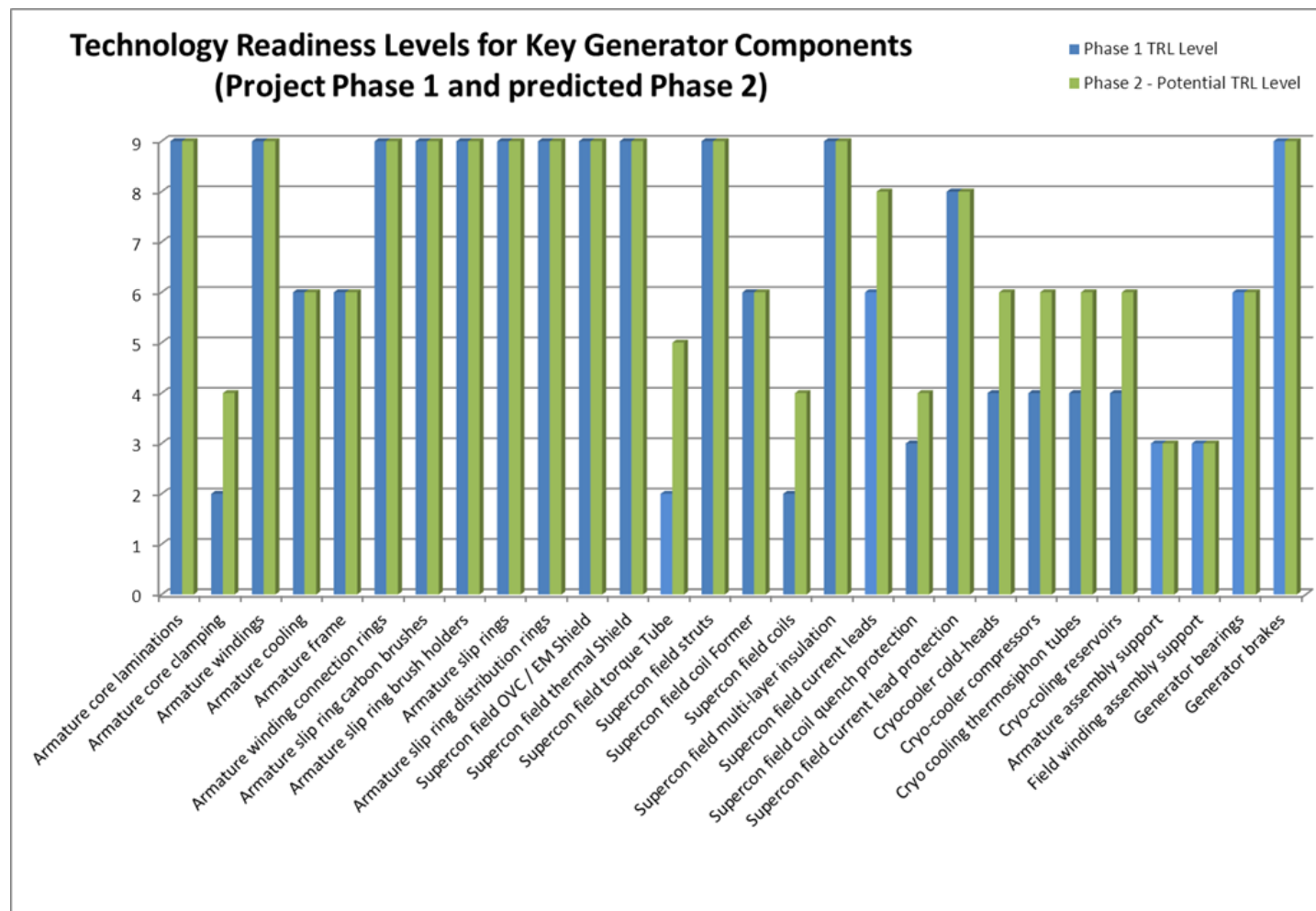

	PHASE 1	PHASE 2 projected
Sub-System	% lower than TRL4	% lower than TRL4
Armature	10 %	0 %
Superconducting Field	28 %	0 %
Cryogenic Cooling	0 %	0 %
Mechanical	43%	28 %

Conclusions

- ❑ Superconductivity is competing against well-established and well-understood technology.
- ❑ The political pressures already exist to reduce the cost of energy and to minimize the effect on the environment.
- ❑ Until we can get systems out there working in the 'real world', we will never get sufficient data to be able to prove once and for all that this technology can be the answer to many of our energy-related problems.

Team acknowledgements

GE-Global Research

Mike Douglass
Wolfgang Stautner
Renuka Rajput-Ghoshal
Patrick Riley
Mike Moscinski
David Wagner
Joo Kim
Suyu Hou
Fulton Lopez
Randy Longtin
James Rochford
Trifon Laskaris
James Bray
Konrad Weeber
Probir Ghoshal
Kiruba Haran
Tsarafidy Raminosoa
Charles Stephens
Bob Zirin
Daniel Erno
Manoj Shah
Jim Alexander
Johanna Wellington
David Wardwell
Ann Agosti
Scott Quirion

Oak Ridge National Laboratory

Robert Duckworth

GE-Energy

Adam Minadeo
Clive Lewis
Joseph Eugene
David Swaffield
Martin Ingles
Henning Marxen

Thank you.

