

# Looking Forward from Twenty Years of Superconducting Single-Photon Detectors

Karl K. Berggren

*berggren@mit.edu*

*Massachusetts Institute of Technology*

*EUCAS, Sept 9th, 2021*

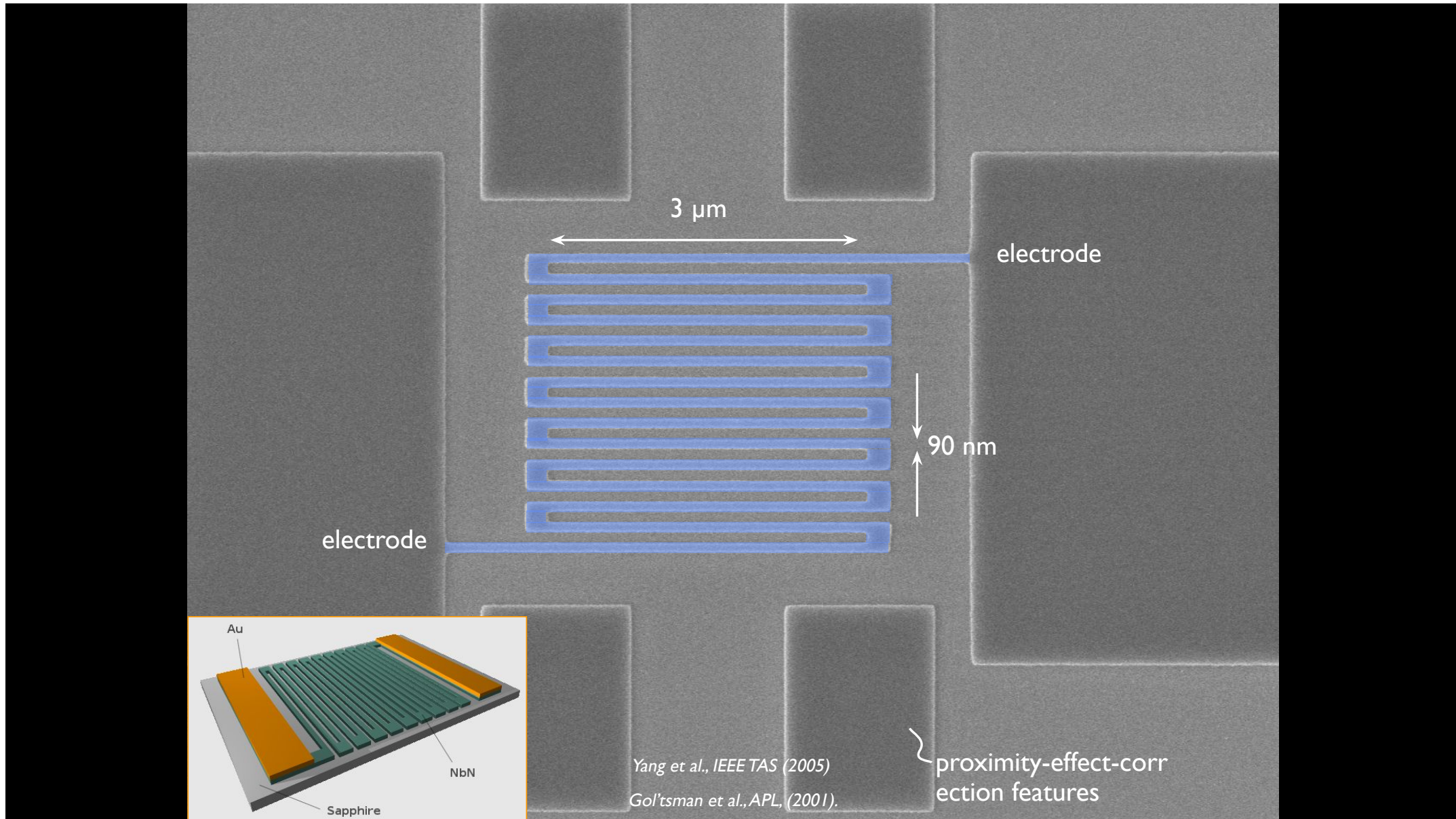

# WHAT IS A PHOTON?

# Characteristics of Photon Detectors

- Efficiency

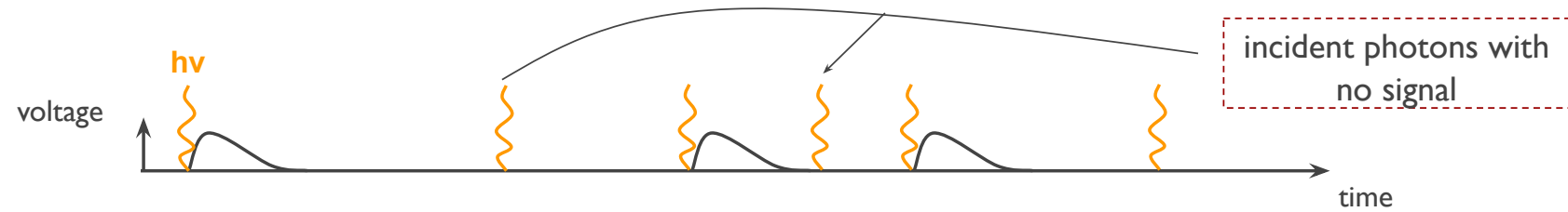

- Reset time

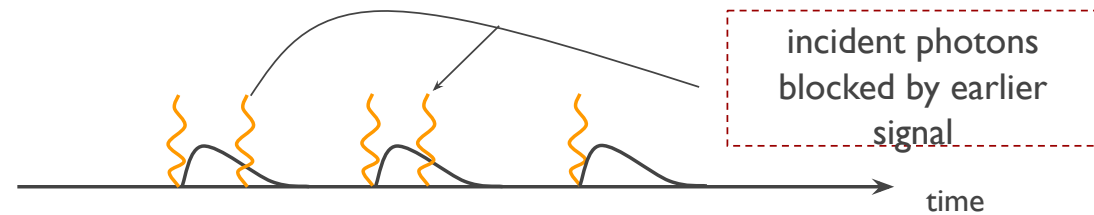

- Jitter

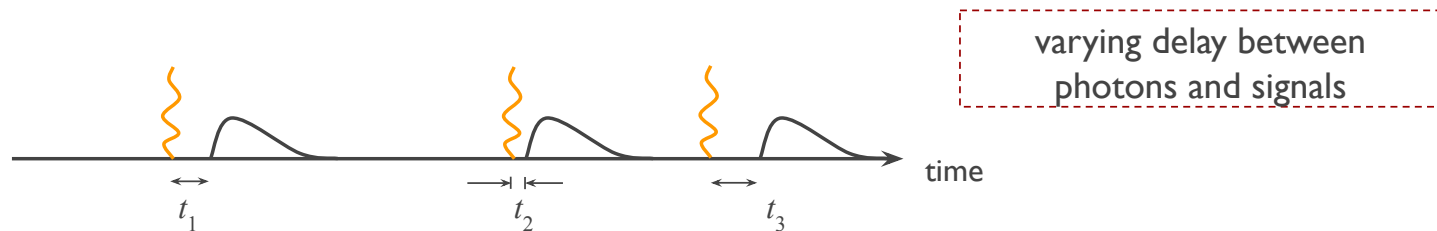

- Dark count rate

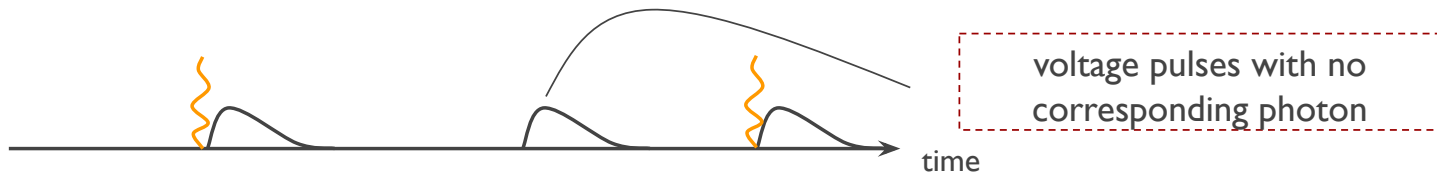

# Why are Superconductors Interesting?

- **Zero resistance**
- **Exclusion of magnetic field**
- **Strong nonlinearity**

# Why are Superconductors Interesting?

- **Zero resistance**
- **Exclusion of magnetic field**
- **Strong nonlinearity**

# Analog Amplifiers

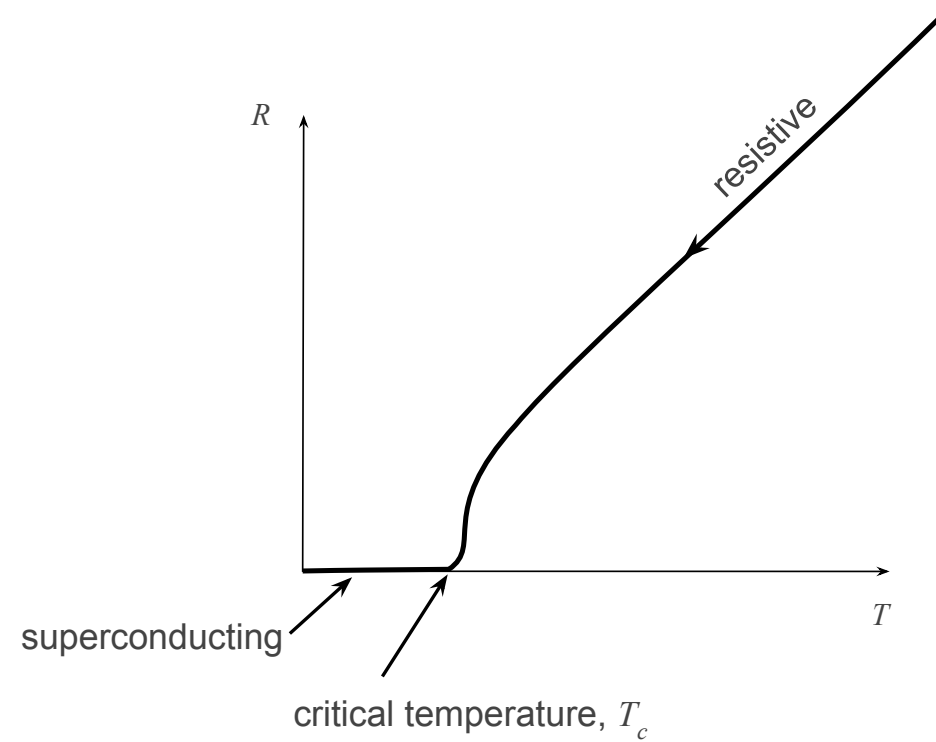

# Comparison-Based Device

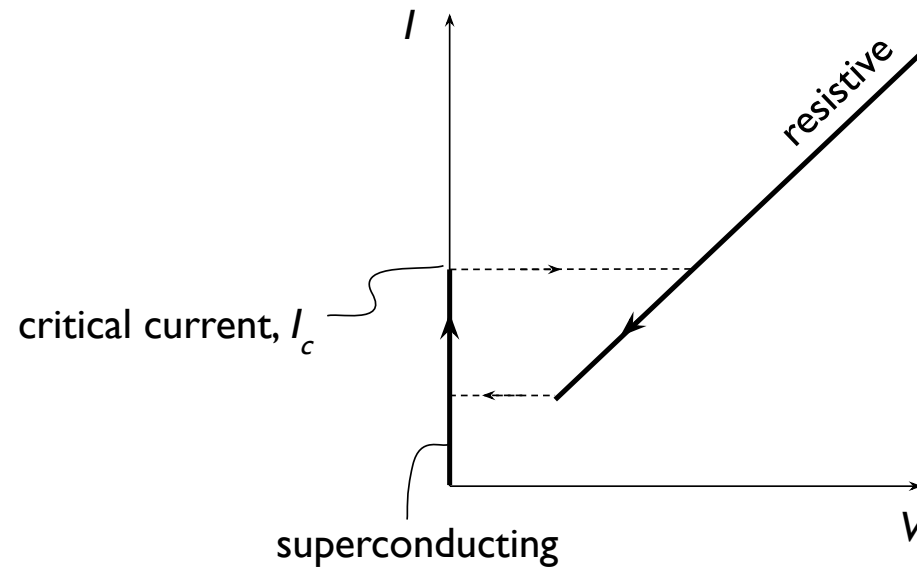



# Comparison-Based Device

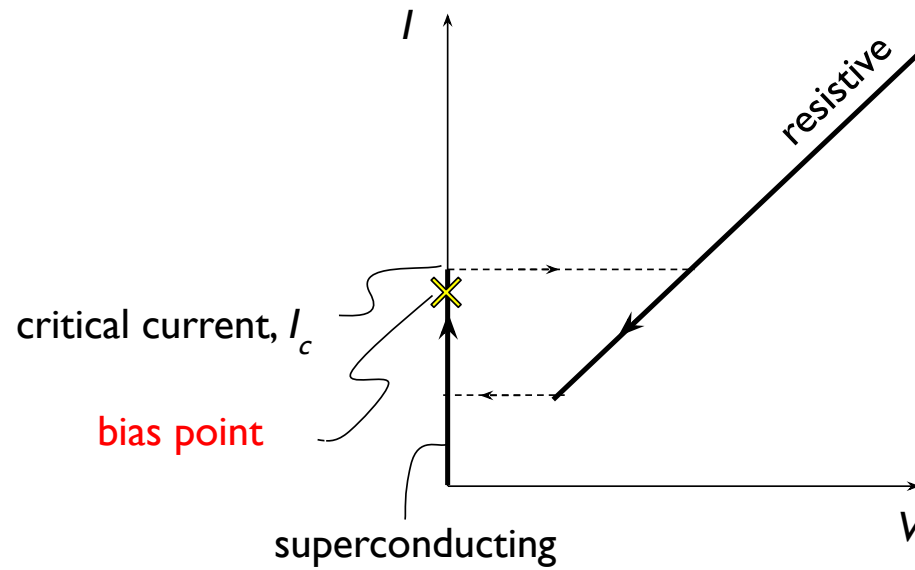

## Why are SNSPDs Special?

- Infrared efficiency for single photons: single photon sensitivity > 5  $\mu\text{m}$
- Jitter: nothing else can match it for single photons
- Efficiency: Transition Edge Sensors are similar, but have other disadvantages
- Count rate (10x to 100x faster reset than competing technologies)
- Dark-count rate: nothing else can match it

# HISTORY OF PHOTODETECTION WITH SUPERCONDUCTORS

Phys. Rev. Lett. **8**, 438 – Published 1 June 1962

## SUPERCONDUCTING NUCLEAR PARTICLE DETECTOR

N. K. Sherman

Queen's University, Kingston, Ontario, Canada

(Received May 2, 1962)

Recently the cryotron was proposed as a detector of nuclear particles.<sup>1</sup> An even simpler detector should be possible, capable of discriminating between particles of different ionizing power. It would consist of a narrow, thin film of current-carrying superconductor cooled well below its transition temperature, in series with a small resistance. Should an ionizing particle pass through the film, the current will be reduced and a voltage pulse will appear across the resistor.

## **Bolometric and nonbolometric infrared photoresponses in ultrathin superconducting NbN films**

M. W. Johnson<sup>a)</sup> and A. M. Herr

*Department of Physics and Astronomy, University of Rochester, Rochester, New York 14627*

A. M. Kadin

*Department of Electrical Engineering, University of Rochester, Rochester, New York 14627*

(Received 16 August 1995; accepted for publication 22 January 1996)

The photoresponse of 10 nm thick superconducting NbN meander lines is measured using an amplitude modulated infrared semiconductor laser operating at a wavelength of 1300 nm. The response time of the film is found to be less than 1 ns with a measured responsivity of up to 1500 V/W of absorbed power at 100 kHz. Thermal properties of the film are extracted from current–voltage characteristics using a self-heating hot spot model. At temperatures well below the superconducting transition, the magnitude of the photoresponse is found to be an order of magnitude too large to be purely bolometric, even when electron heating and effects due to intergranular weak links are taken into account. The photoresponse is seen to be bolometric near  $T_c$ . Other contributions to photoresponse are discussed, including kinetic inductance and the photofluxonic effect. © 1996 American Institute of Physics. [S0021-8979(96)04209-2]

Journal of Applied Physics 79, 7069 (1996)

## Picosecond superconducting single-photon optical detector

G. N. Gol'tsman,<sup>a)</sup> O. Okunev, G. Chulkova, A. Lipatov, A. Semenov, K. Smirnov, B. Voronov, and A. Dzardanov  
 Department of Physics, Moscow State Pedagogical University, Moscow 119435, Russia

C. Williams and Roman Sobolewski<sup>b)</sup>  
 Department of Electrical and Computer Engineering and Laboratory for Laser Energetics, University of Rochester, Rochester, New York 14627-0231

(Received 22 January 2001; accepted for publication 1 June 2001)

We experimentally demonstrate a supercurrent-assisted, hotspot-formation mechanism for ultrafast detection and counting of visible and infrared photons. A photon-induced hotspot leads to a temporary formation of a resistive barrier across the superconducting sensor strip and results in an easily measurable voltage pulse. Subsequent hotspot healing in  $\sim 30$  ps time frame, restores the superconductivity (zero-voltage state), and the detector is ready to register another photon. Our device consists of an ultrathin, very narrow NbN strip, maintained at 4.2 K and current-biased close to the critical current. It exhibits an experimentally measured quantum efficiency of  $\sim 20\%$  for  $0.81 \mu\text{m}$  wavelength photons and negligible dark counts. © 2001 American Institute of Physics. [DOI: 10.1063/1.1388868]

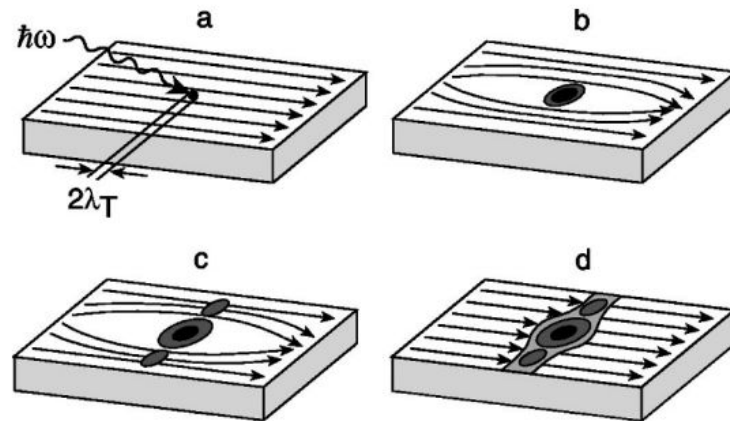

FIG. 1. Schematics of the supercurrent-assisted hotspot formation mechanism in an ultrathin and narrow superconducting strip, kept at temperature far below  $T_C$  are shown. The arrows indicate direction of the supercurrent flow.

Appl. Phys. Lett., Vol. 79, No. 6, 6 August 2001

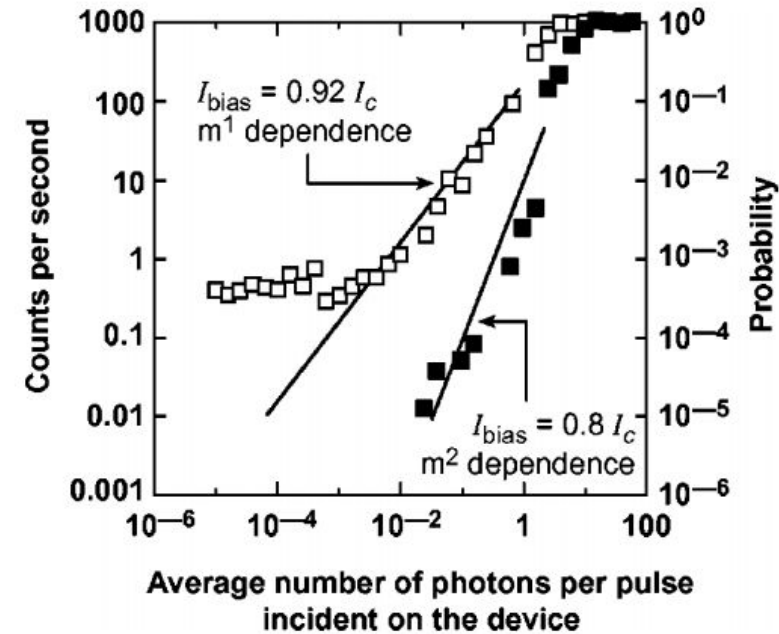

FIG. 3. Number of counts per second recorded by the NbN SPD versus the average number of photons per pulse incident upon the device, for two different bias current levels is shown. The solid lines correspond to the Eq. (4) theoretical predictions. The incident photon wavelength was  $0.81 \mu\text{m}$ .

# The IEEE Award for Continuing and Significant Contributions in the Field of Applied Superconductivity

Gregory Goltsman



Details

**Affiliation:** Moscow State Pedagogical University

## AWARD RECIPIENT

For continuing and significant contributions in the field of superconductive electronics, in particular:

- for invention and advancement of the superconducting hot-electron bolometric mixer, now one of the key astrophysics detectors,
- for invention and advancement of the superconducting single-photon detector, which has enabled new high-speed optical communication applications, and
- for contributions to the understanding of electron energy relaxation processes in impure superconducting films.

# SNSPD Experimental Timeline

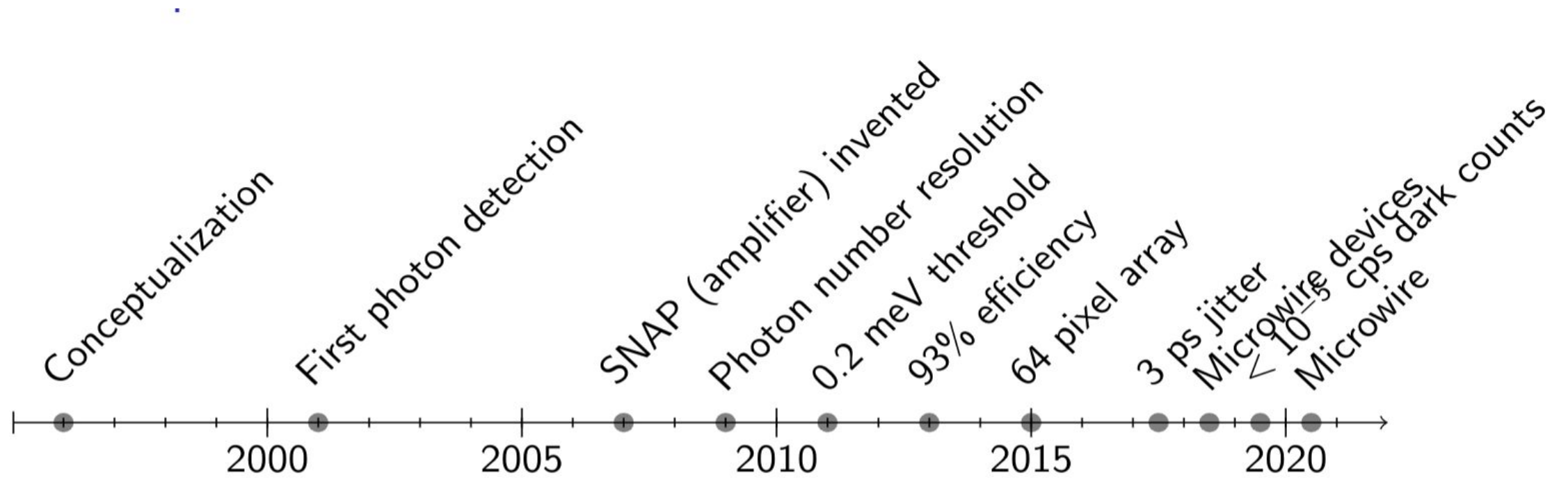



# SNSPD Theory Timeline

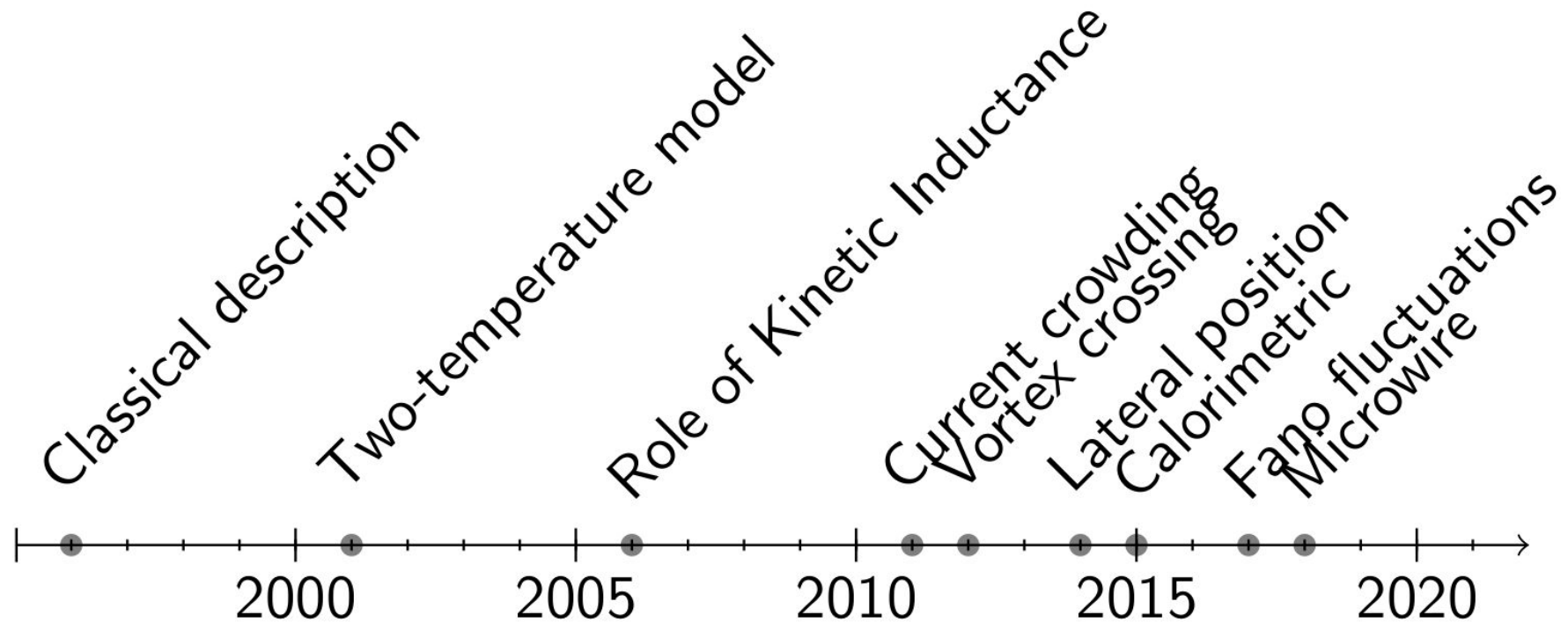

# Applications of SNSPDs

A microscopic image of a superconducting circuit, likely a readout line for a superconducting nanowire single-photon detector (SNSPD). The image shows a grid of meander lines (U-shaped structures) on a dark substrate. A central readout line runs horizontally across the middle of the grid. The meander lines are arranged in a regular pattern, and the readout line is a single, straight line.

# VLSI Circuit Evaluation

VLSI circuit  
imaging and  
debugging

SNSPD  
enabled  
performance  
advances



Image courtesy of DCG Systems

Collaboration between BU, DCG Systems\*, IBM, Photonspot, funded by IARPA  
\* Now Thermofisher

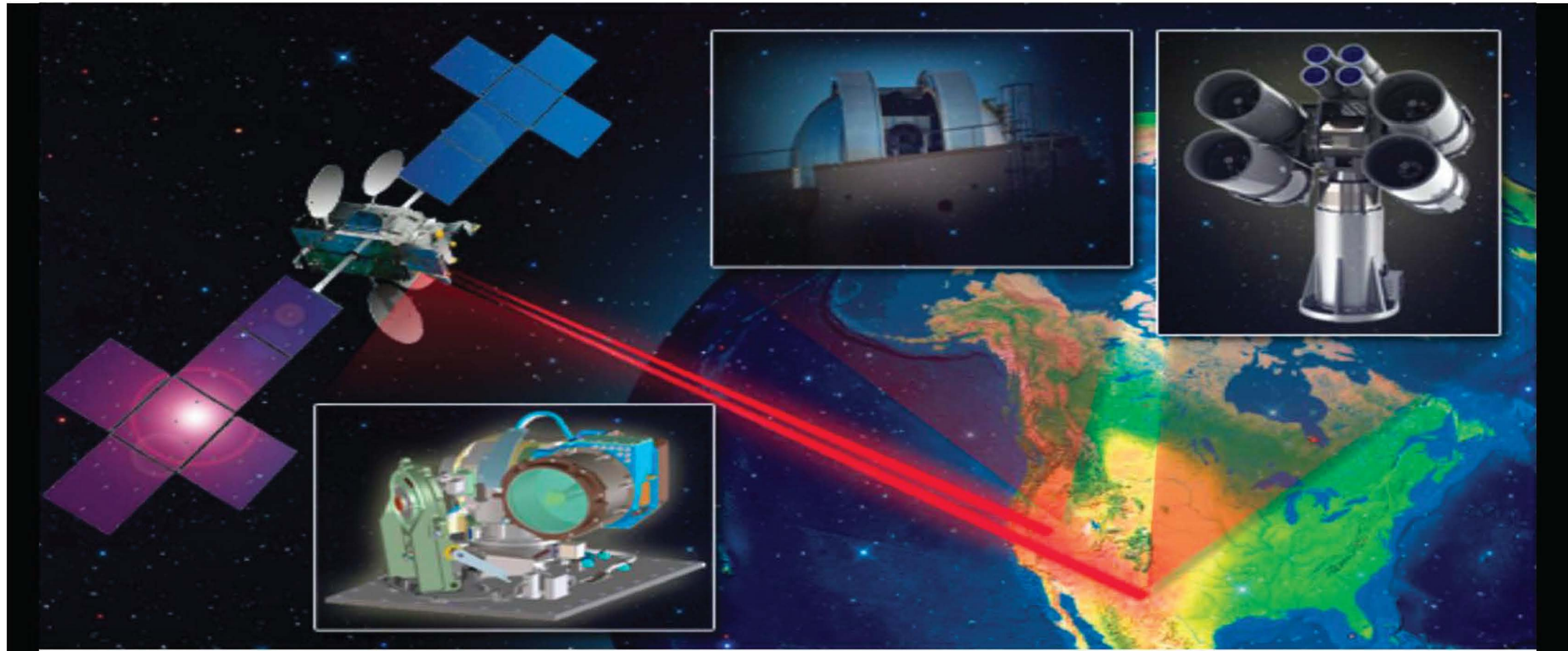

“... the first high-rate space laser communications system that can be operated over a range ten times larger than the near-Earth ranges that have been demonstrated to date.” from <http://esc.gsfc.nasa.gov/267/271.html>, enabled by nanowire detectors developed at Lincoln Laboratory and JPL in collaboration with MIT campus.



# Infrared single-photon LIDAR with SNSPDs

University of Glasgow, UK & partners

**1 km range daylight depth imaging at 1550 nm wavelength**  
McCarthy *et al* Optics Express 21 8904 (2013) Glasgow/Heriot-Watt/Delft

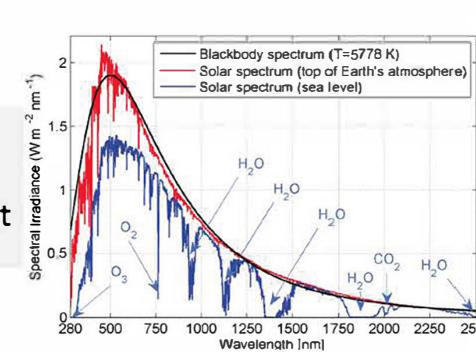
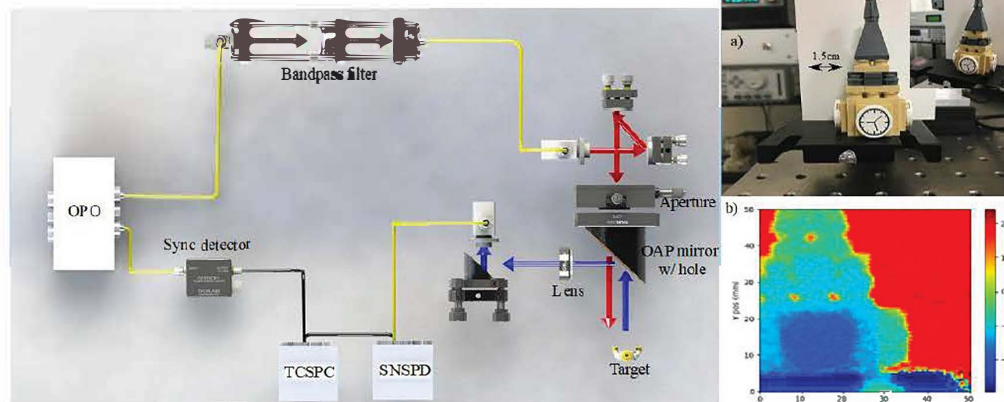

**Benchtop depth imaging at 2.3 μm wavelength**  
Taylor *et al* Optics Express 27 8147 (2019) Glasgow/NICT

**Low jitter SNSPD LIDAR field trials at 1550 nm wavelength**  
Taylor *et al* CLEO SM2M.6 (2020) Glasgow/Heriot-Watt/JPL

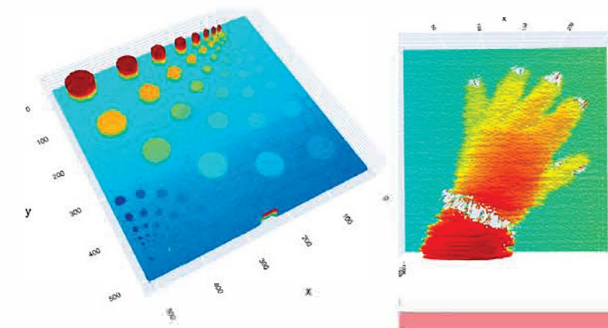

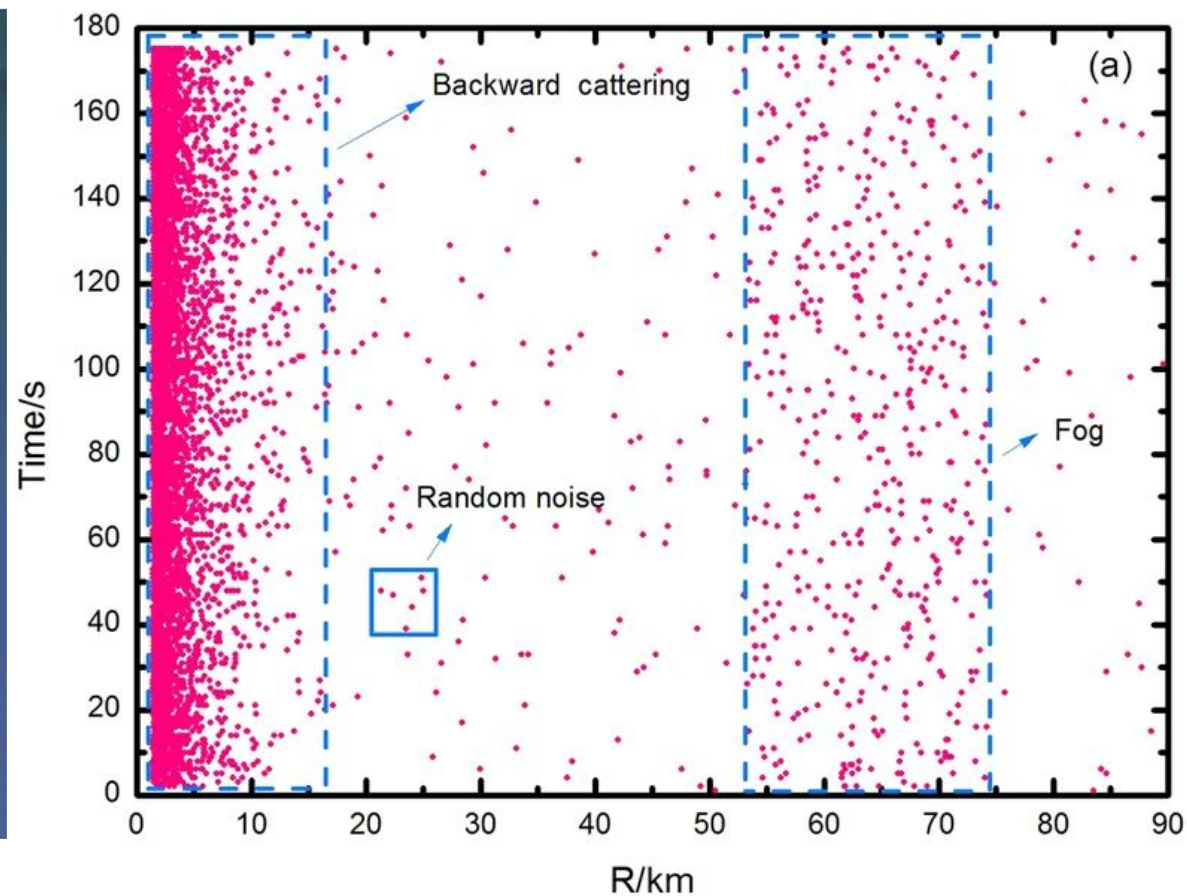

Zhu, J., Chen, Y., Zhang, L. *et al.*  
Demonstration of measuring sea fog  
with an SNSPD-based Lidar system.  
*Sci Rep* 7, 15113 (2017).



University  
of Glasgow

# Quantum Key Distribution

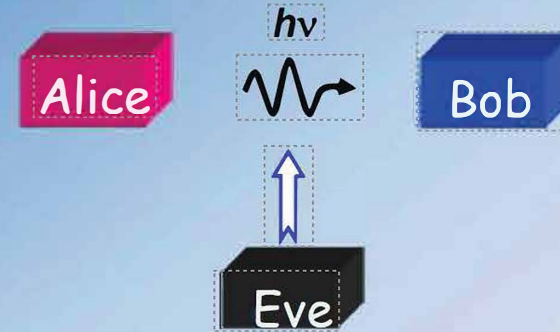

- Principle: a secret key is generated over a public channel with security guaranteed by laws of Quantum Mechanics
- Information encoded on the phase or polarization of individual photons
- Eavesdropping introduces errors

Robert Hadfield • Heraeus Seminar Bad Honnef • 15<sup>th</sup> November 2018

 **University of Glasgow** **Quantum Communications Milestones with SNSPDs**

Tokyo QKD Network  
 Sasaki *et al.* Optics Express 19 10387 (2011)

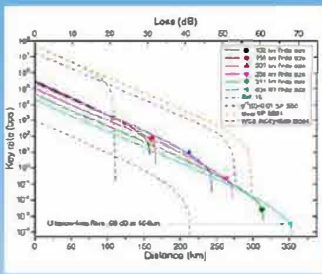

MDI-QKD over 404 km optical fibre  
 Yin *et al.* Phys. Rev. Lett. 117 190501 (2016)

Entanglement distribution over 91 km submarine fibre  
 arXiv:1803.00583

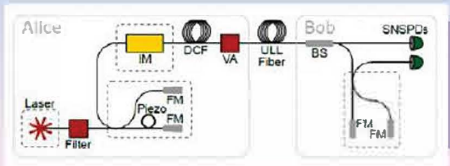
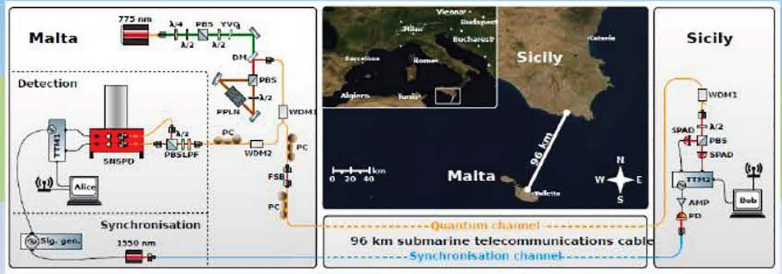

QKD over 421 km optical fibre  
 Boaron *et al.* Phys. Rev. Lett. 121 190502 (2018)

Robert Hadfield • Heraeus Seminar Bad Honnef • 14<sup>th</sup> November 2018

Slide courtesy of Robert Hadfield



## "Loophole-free" Bell test (2015)

NIST

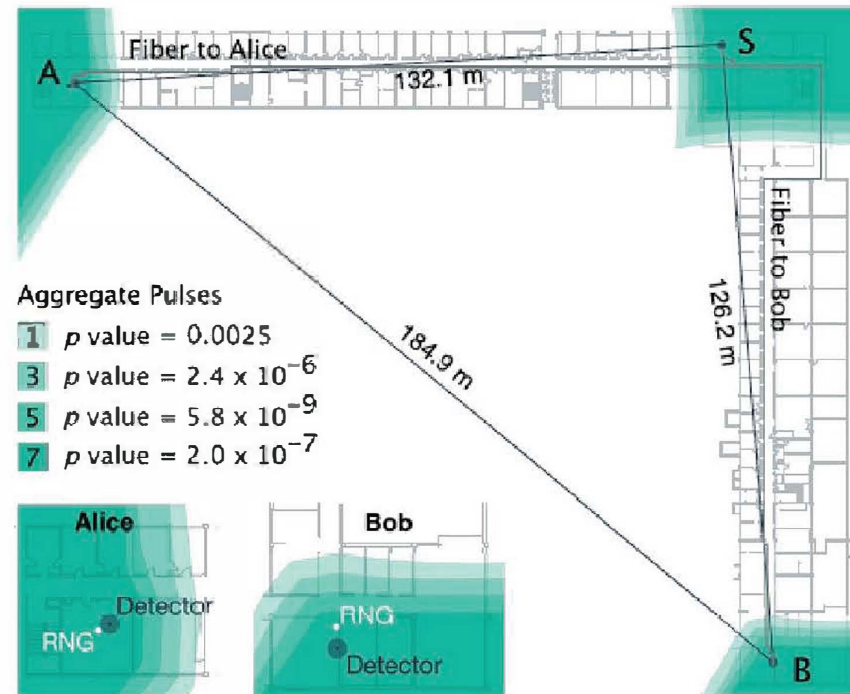

*L. K. Shalm et. al, PRL 115, 250402 (2015)*

Two high-efficiency WSi SNSPDs used to close loopholes in prior Bell's inequality experiments

*Slide courtesy of Sae-Woo Nam*

# Dark Matter Detection

- Not just matter that's hard to see!
- We know it's there because... gravity
  - Velocity vs. radius of galaxial matter
  - Explains observed gravitational lensing
  - Explains galaxial collisions
- Does it interact in any other way?
- What is it?

### Nanowire Detection of Photons from the Dark Side

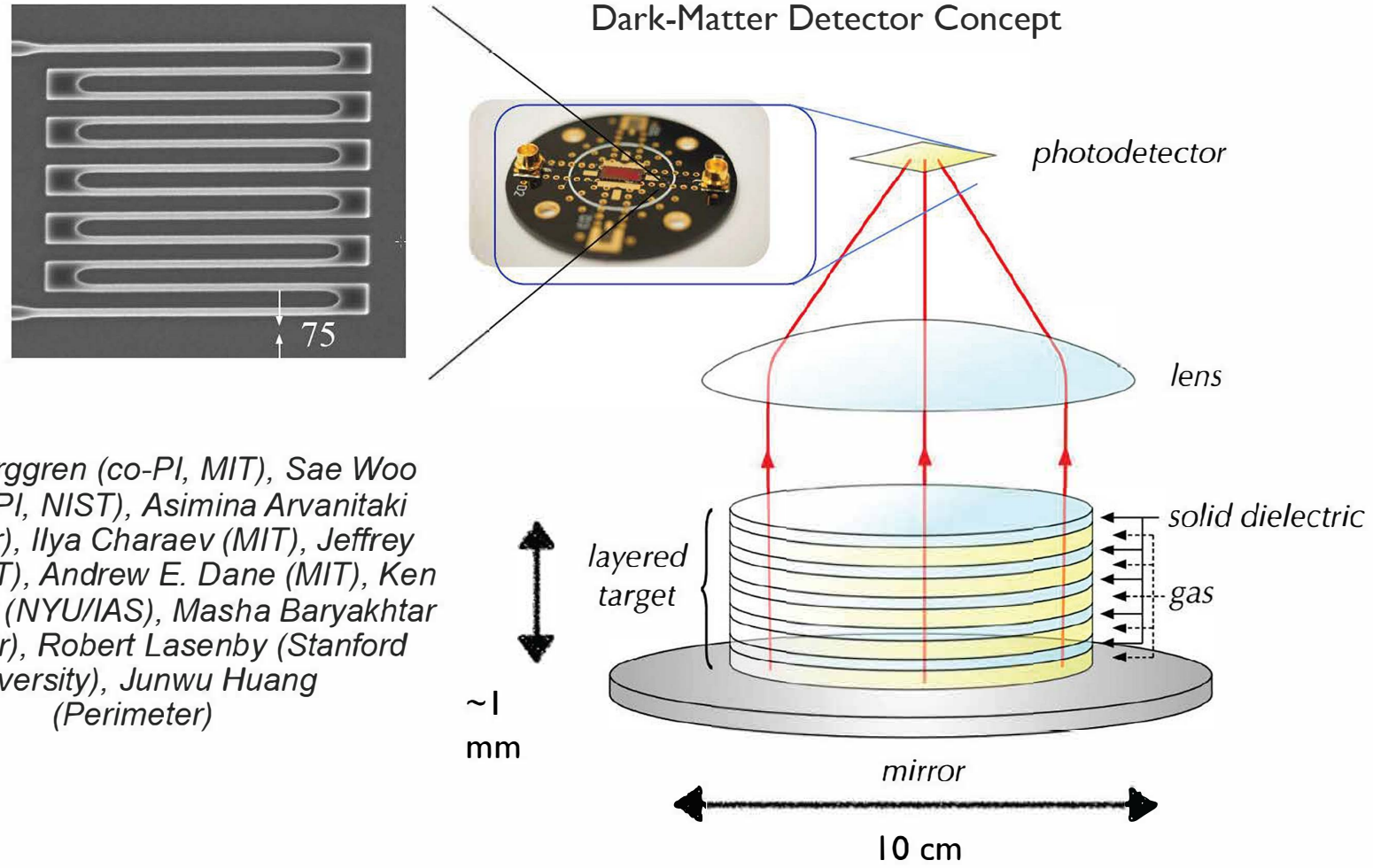

Karl K. Berggren (co-PI, MIT), Sae Woo Nam (co-PI, NIST), Asimina Arvanitaki (Perimeter), Ilya Charaev (MIT), Jeffrey Chiles (NIST), Andrew E. Dane (MIT), Ken Van Tilburg (NYU/IAS), Masha Baryakhtar (Perimeter), Robert Lasenby (Stanford University), Junwu Huang (Perimeter)

## Nanowire Detection of Photons from the Dark Side

Karl K. Berggren (co-PI, MIT), Sae Woo Nam (co-PI, NIST), Asimina Arvanitaki (Perimeter), Ilya Charaev (MIT), Jeffrey Chiles (NIST), Andrew E. Dane (MIT), Ken Van Tilburg (NYU/IAS), Masha Baryakhtar (Perimeter), Robert Lasenby (Stanford University), Junwu Huang (Perimeter)

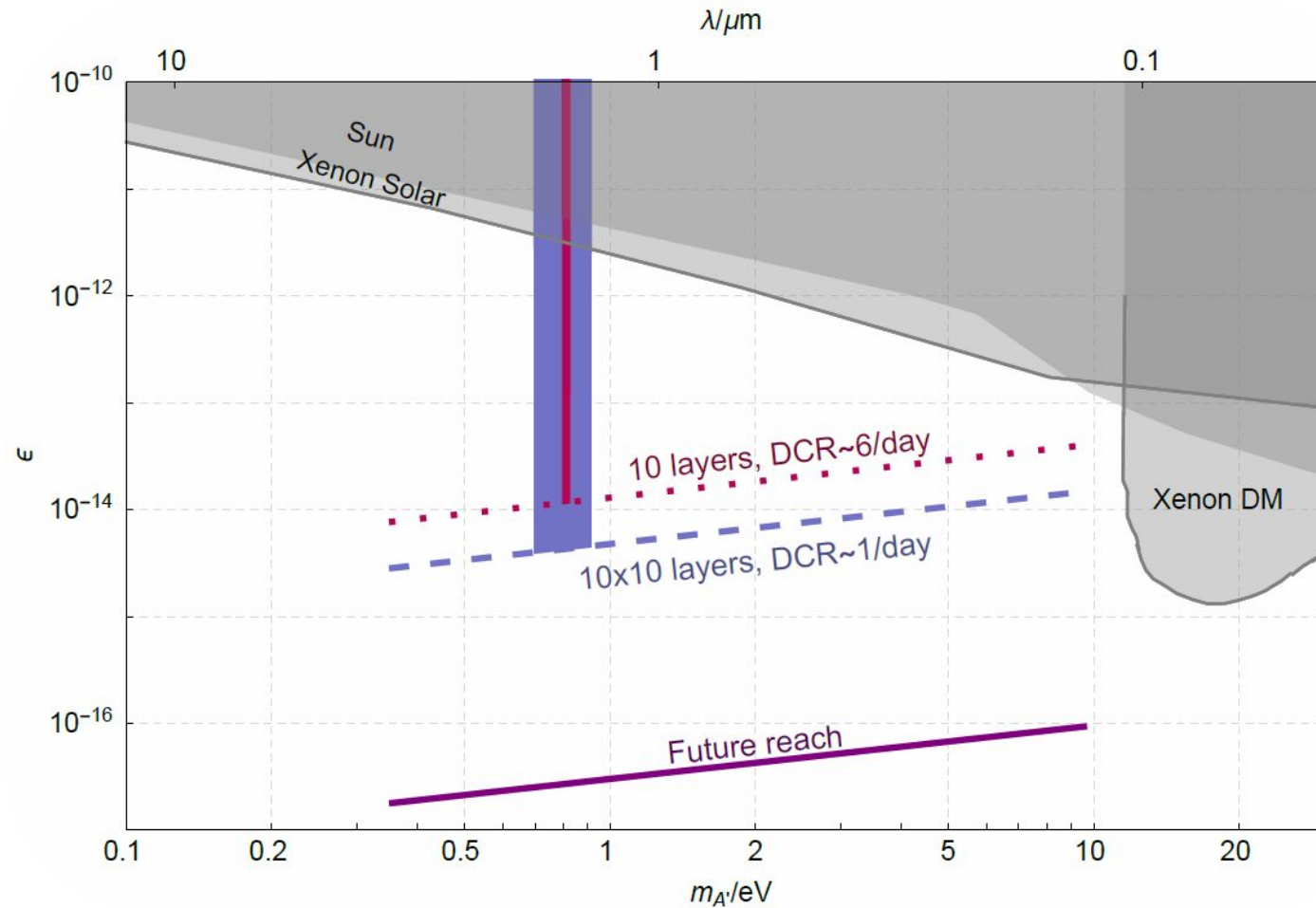

## Detecting Dark Matter with Superconducting Nanowires

Yonit Hochberg<sup>1,\*</sup> Ilya Charaev<sup>2,†</sup> Sae-Woo Nam<sup>3,‡</sup> Varun Verma<sup>3,§</sup> Marco Colangelo<sup>2,¶</sup> and Karl K. Berggren<sup>2,\*\*</sup>

<sup>1</sup>Racah Institute of Physics, Hebrew University of Jerusalem, Jerusalem 91904, Israel

<sup>2</sup>Massachusetts Institute of Technology, Department of Electrical Engineering and Computer Science, Cambridge, MA, USA and

<sup>3</sup>National Institute of Standards and Technology, Boulder, CO, USA

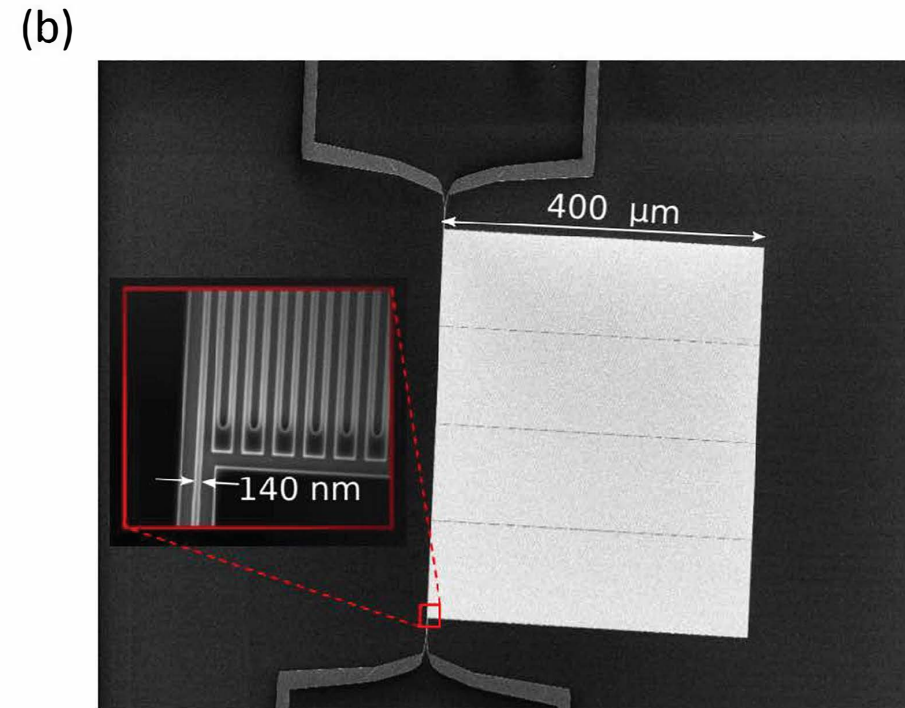
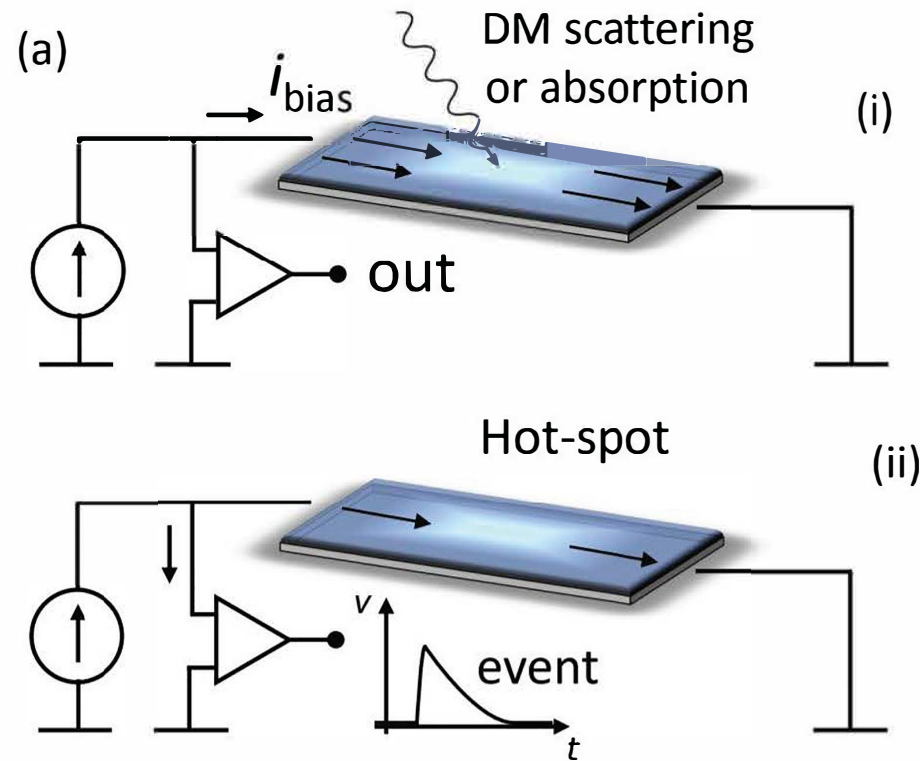

Phys. Rev. Lett. 123, 151802 (2019)

# Bio applications: (towards) Fluorescence-lifetime imaging microscopy (FLIM) with SNSPDs

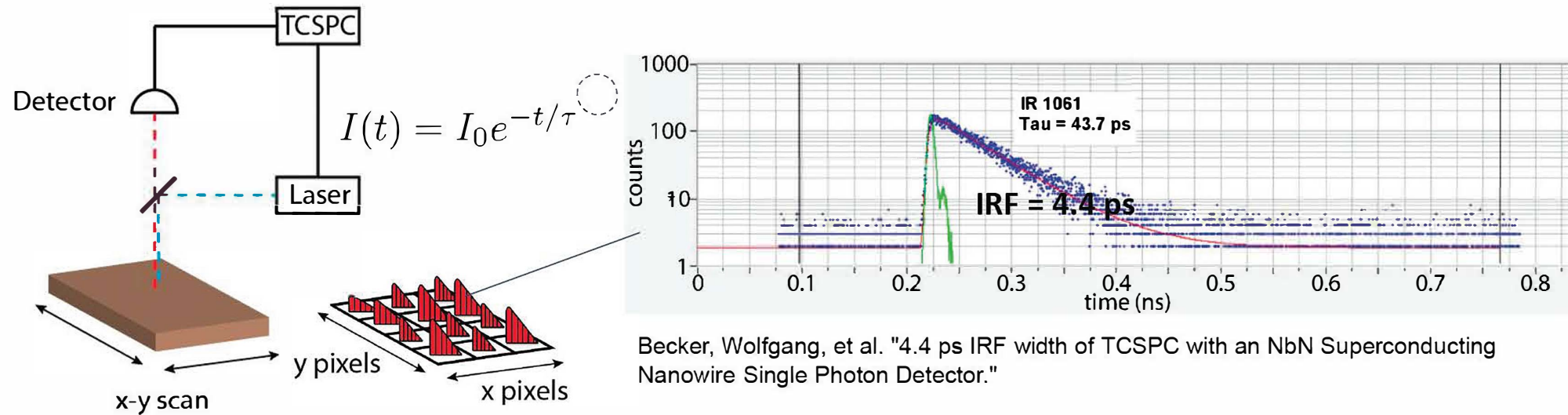

Becker, Wolfgang, et al. "4.4 ps IRF width of TCSPC with an NbN Superconducting Nanowire Single Photon Detector."

FLIM image of a convallaria (plant) not with SNSPDs

- Colors: different decay time
- Brightness: signal

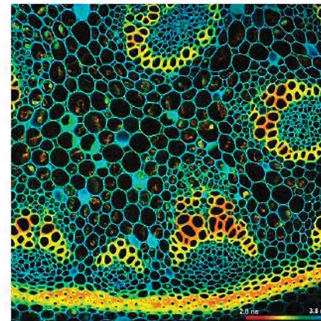

Advantages of SNSPD as a FLIM detector

- Fast instrument response function (IRF)
- Resolving fast decay fluorophores
- Enable use of new fluorophores

# Computational Imaging & Spectroscopy using SNSPDs

Superconducting Quantum Electronics & Photon Information Lab



**Qing-Yuan Zhao**  
 Professor of School of Electronic Science and Engineering,  
 Nanjing University, China

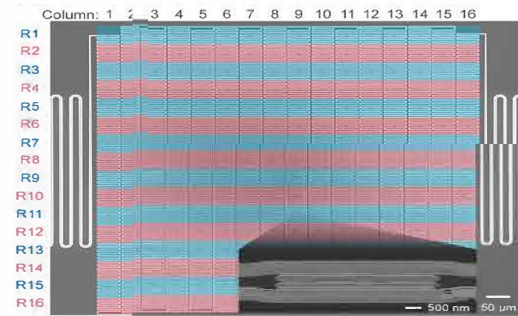

## Noise-tolerant single-photon computational imaging

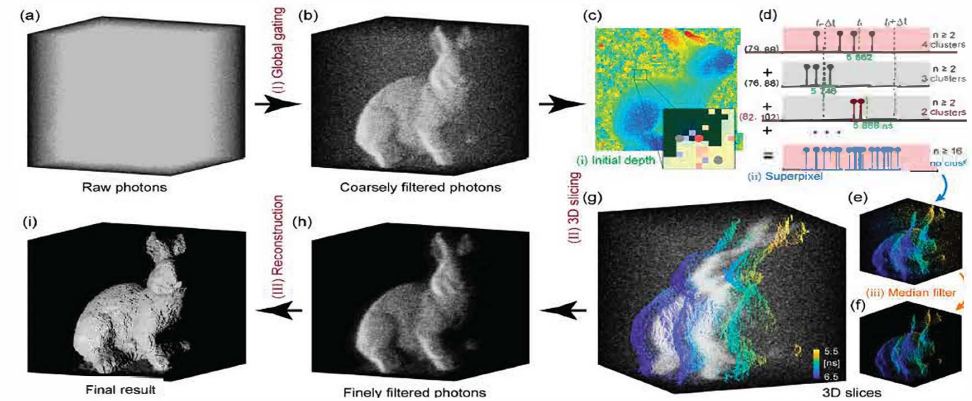

Opt. Lett. 45(24), 6732 (2020).

## Computational Spectrometer using a modulated SNSPD

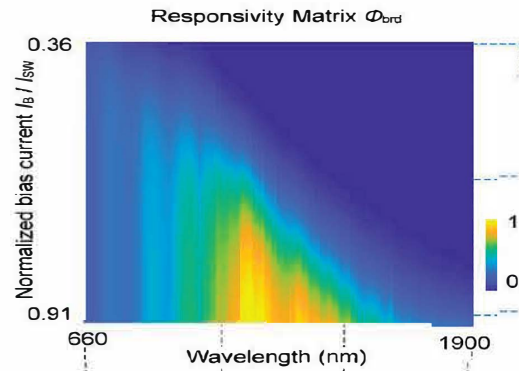
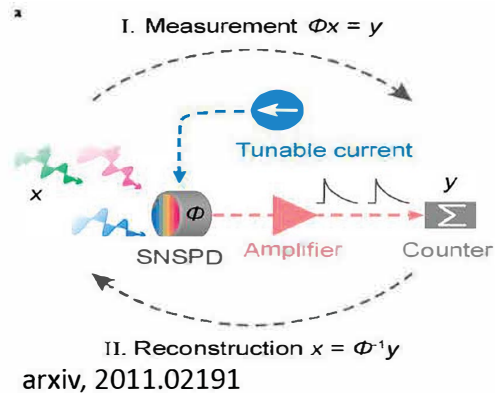

## Spectral LiDAR

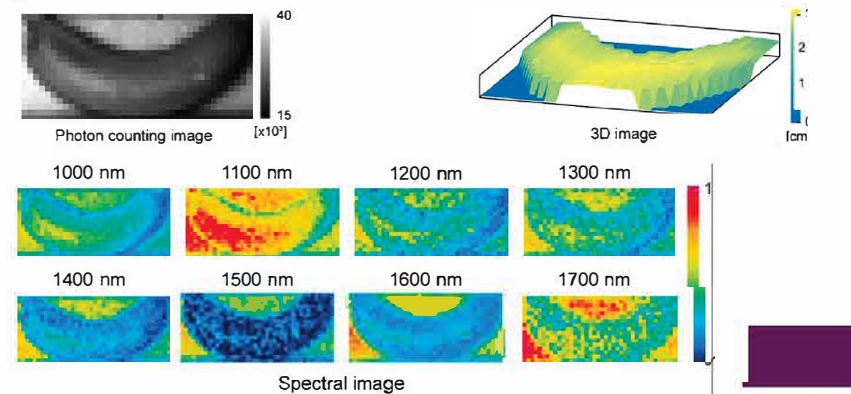







California Institute of Technology

## Scaling to Kilopixel Arrays

Jet Propulsion  
Laboratory

- Demonstration of **1024-pixel imaging array** with  $> 99\%$  pixel yield
- $32 \times 32$  imager read out using only 64 readout lines
- $30 \times 30 \mu\text{m}$  active area on  $50 \mu\text{m}$  pitch – total area  $0.92 \text{ mm}^2$

**NIST**

FABRICATED AT NIST  
TESTED AT JPL



Emma E. Wollman, Varun B. Verma, Adriana E. Lita, William H. Farr, Matthew D. Shaw, Richard P. Mirin, and Sae Woo Nam, "Kilopixel array of superconducting nanowire single-photon detectors," *Opt. Express* 27, 35279-35289 (2019)

## High-time-resolved 64-channel single-flux quantum-based address encoder integrated with a multi-pixel superconducting nanowire single-photon detector

SHIGEYUKI MIYAJIMA,<sup>1,\*</sup> MASAHIRO YABUNO,<sup>1</sup> SHIGEHITO MIKI,<sup>1,2</sup> TARO YAMASHITA,<sup>3,4</sup> AND HIROTAKE TERAI<sup>1</sup>

<sup>1</sup>National Institute of Information and Communications Technology, 588-2 Iwaoka, Nishi-ku, Kobe 651-2492, Japan

<sup>2</sup>Graduate School of Engineering Faculty of Engineering, Kobe University, 1-1 Rokko-dai cho, Nada-ku, Kobe 657-0013, Japan

<sup>3</sup>Graduate school of Engineering, Nagoya University, Furo-cho, Chikusa-ku, Nagoya 464-8603, Japan

<sup>4</sup>PRESTO, Japan Science and Technology Agency, 4-1-8 Honcho, Kawaguchi, Saitama 332-0012, Japan

\*miyajima@nict.go.jp

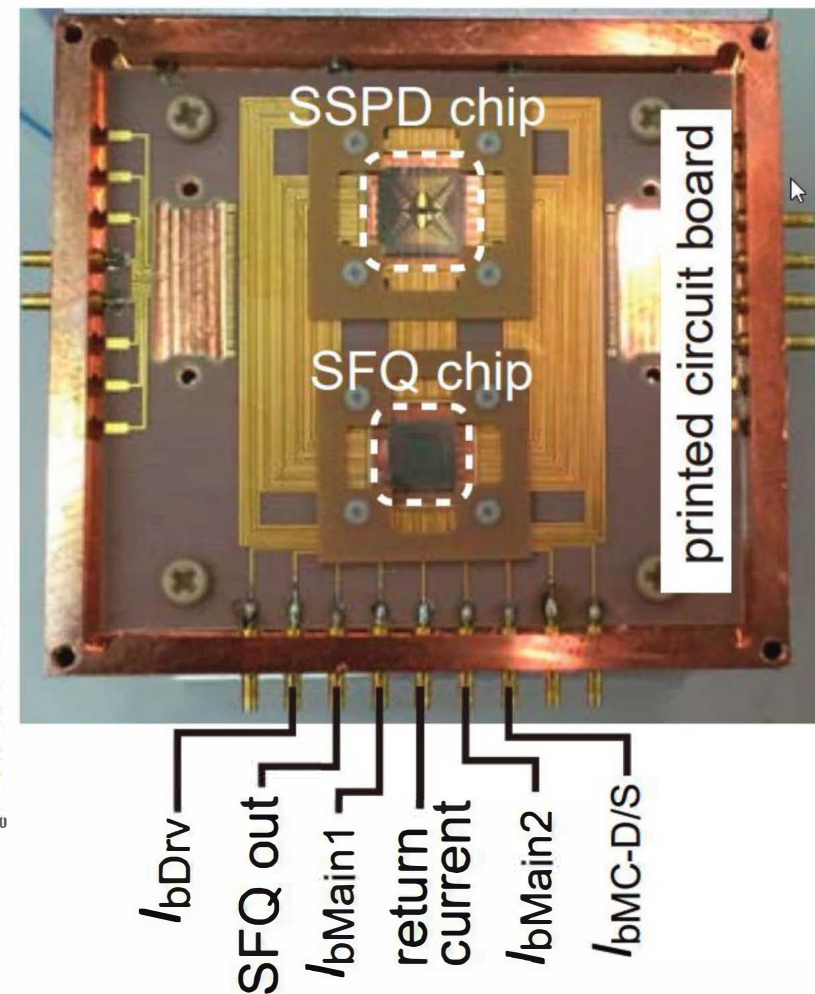
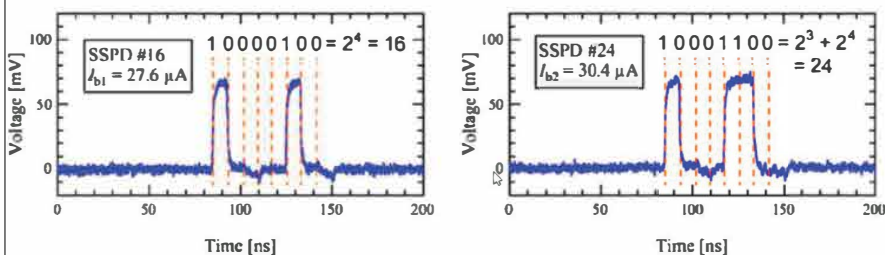

# How Do Superconducting Nanowires Switch and Reset?

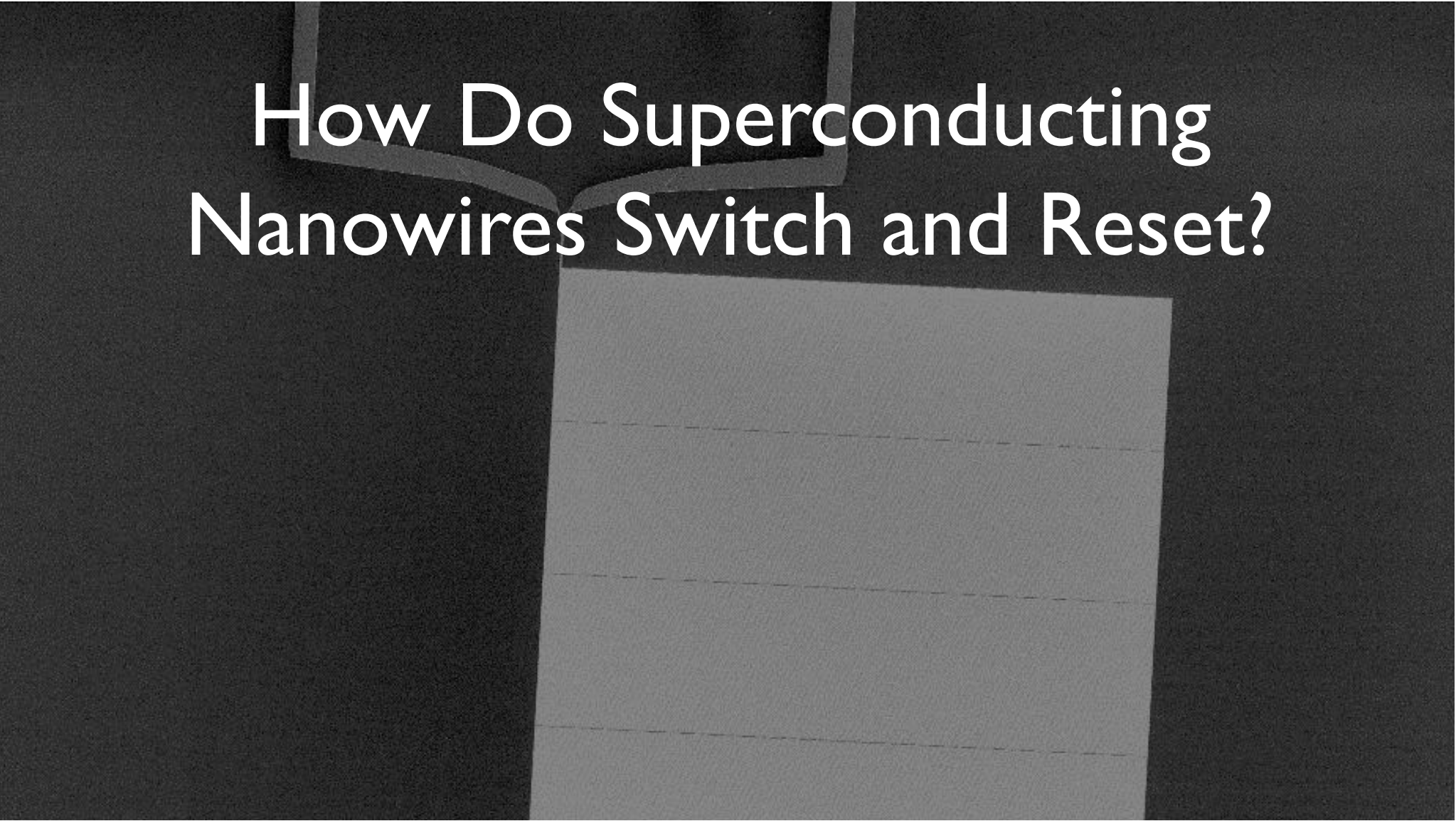

# Current Bias

Critical Temperature  $\sim 11$  K

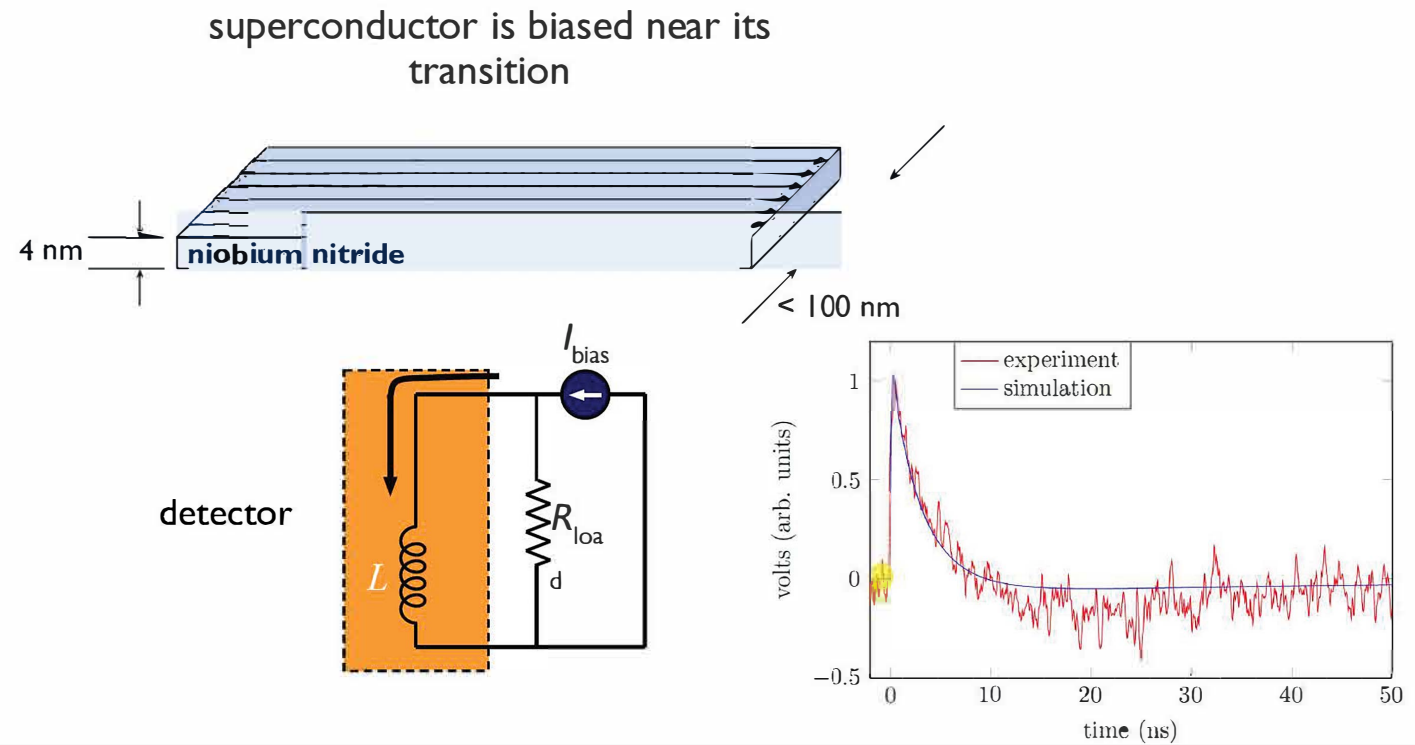

# Absorption

Critical Temperature  $\sim 11$  K

photon-induced hotspot forces bias current above critical density

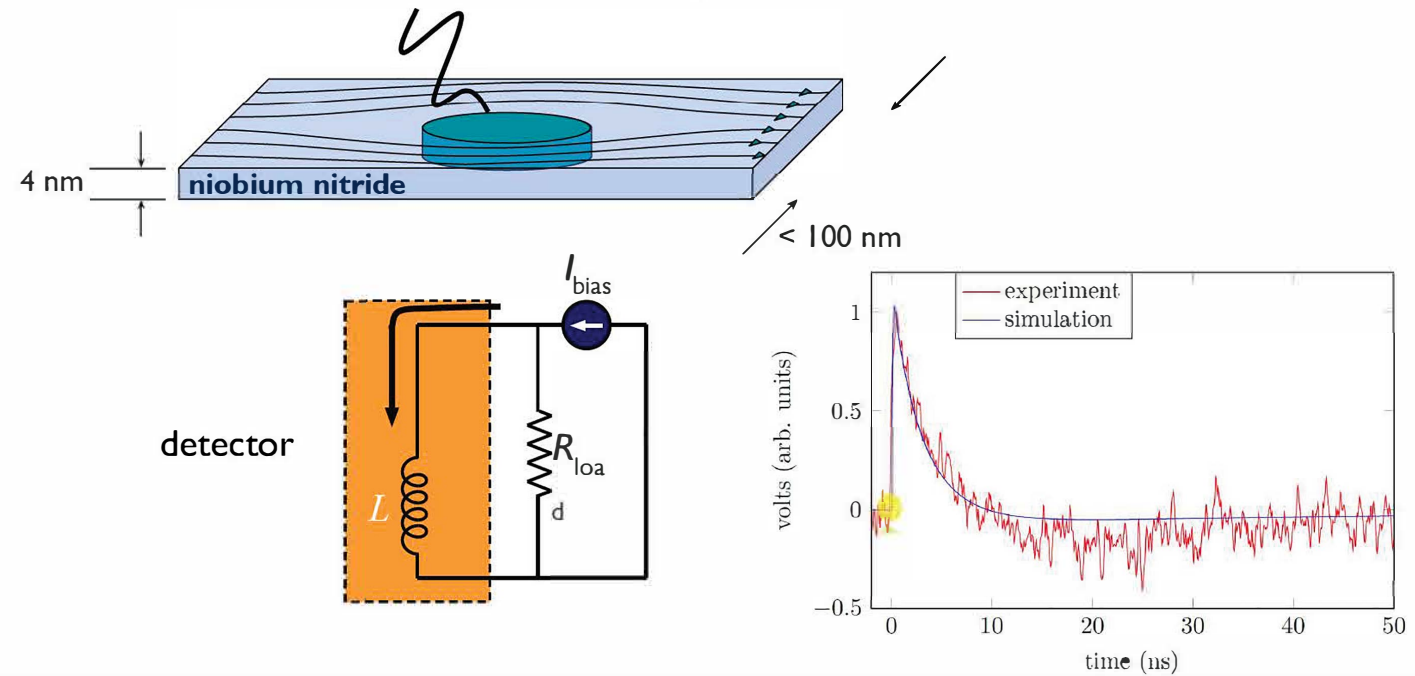

# Breakdown

Critical Temperature  $\sim 11$  K

resistive barrier spans nanowire

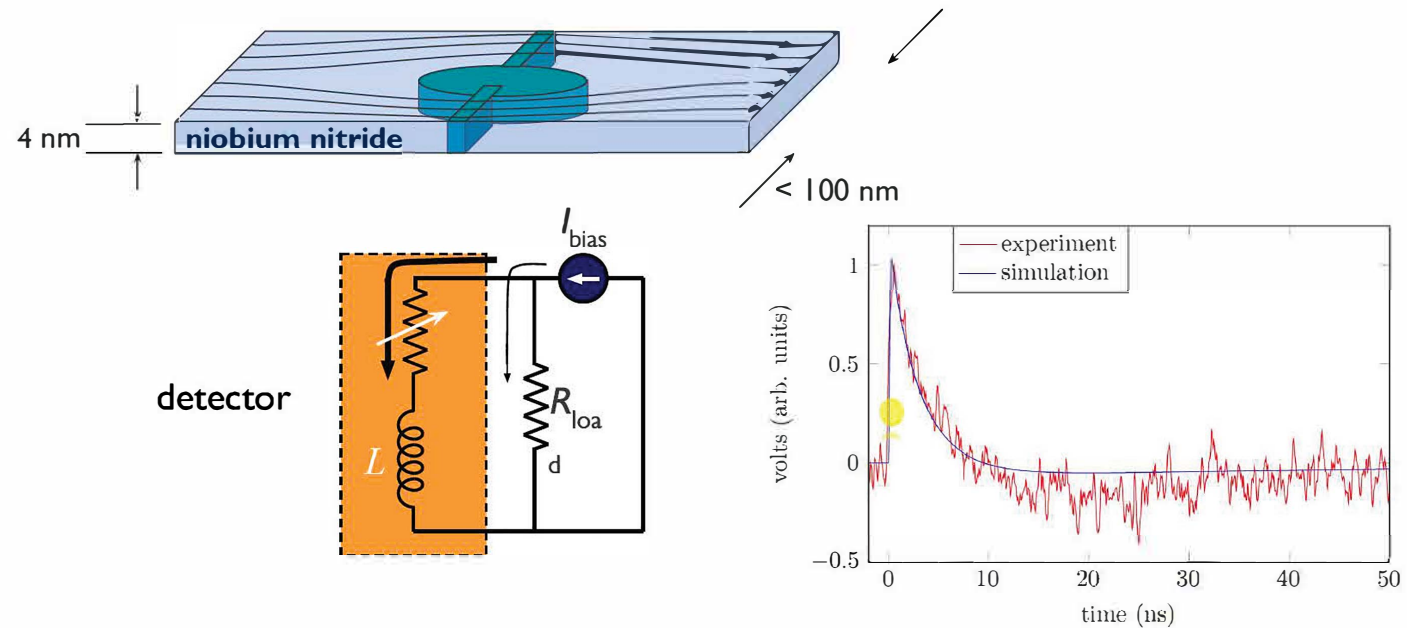

# Acceleration/Heating

Critical Temperature  $\sim 11$  K

resistance grows from heating

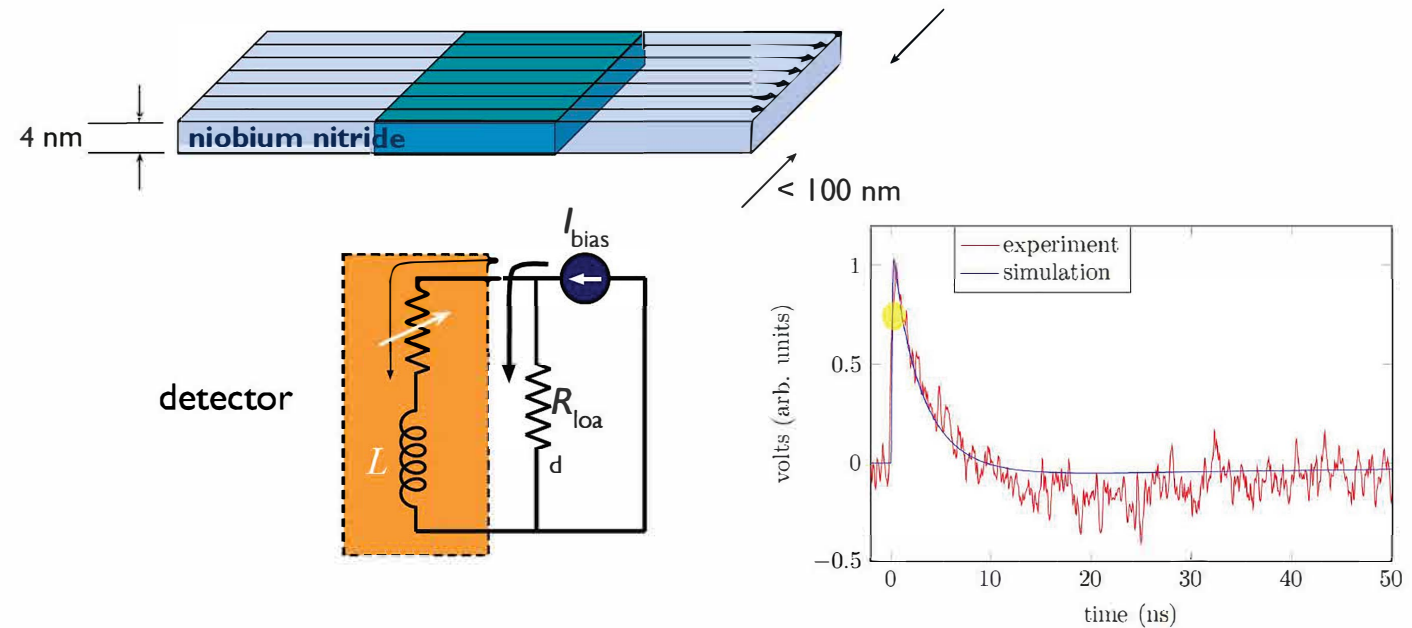

# Diversion of Current

Critical Temperature  $\sim 11$  K

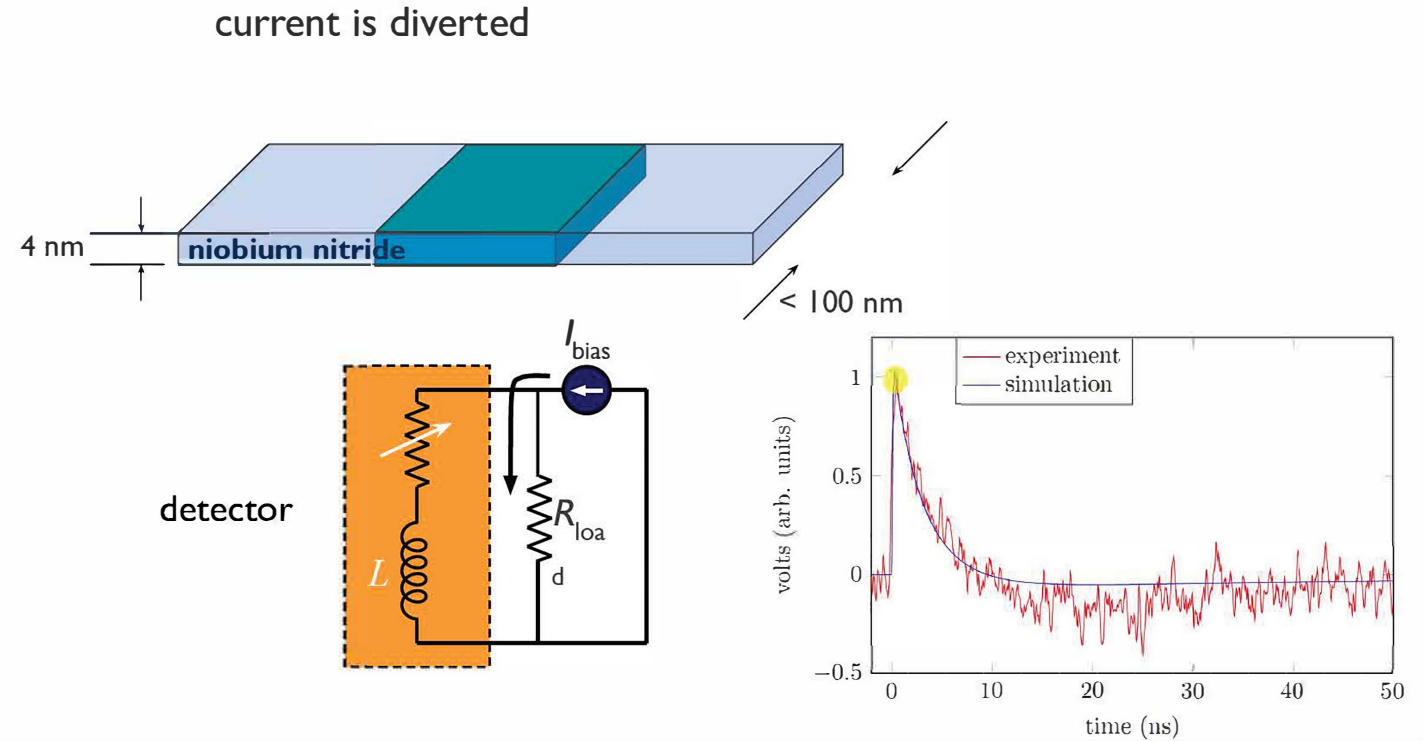



# Cooling

current is diverted  
Critical Temperature  $\sim 11$  K

superconductivity is restored

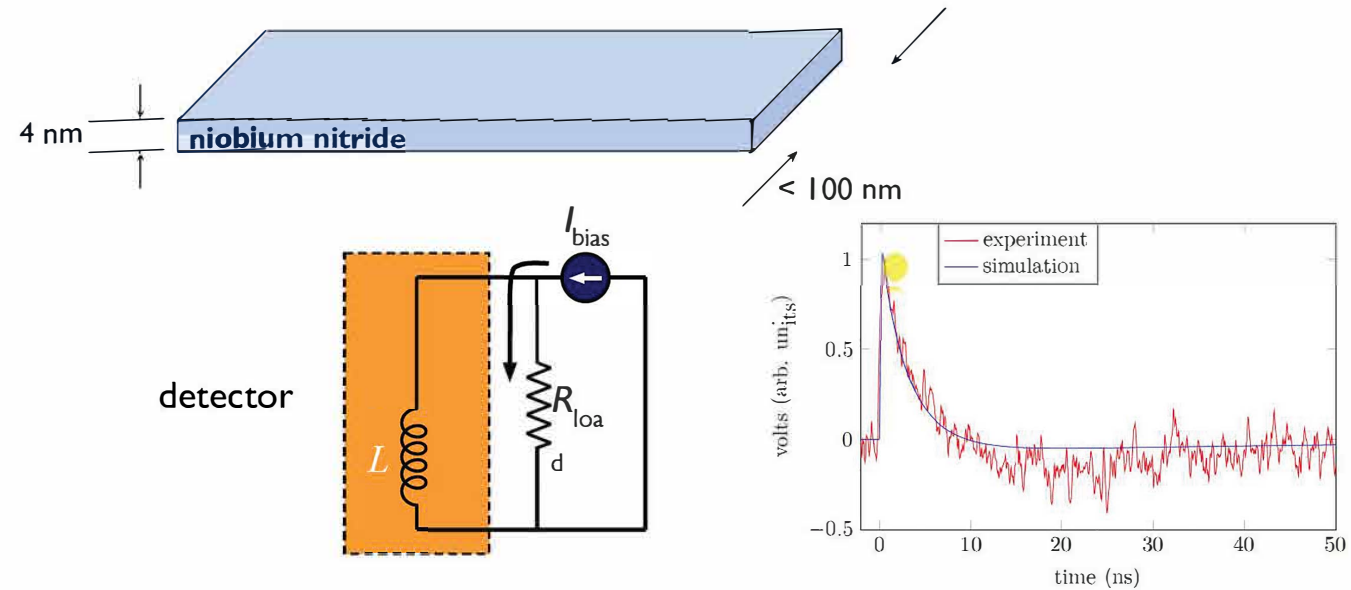

# Reset

Critical Temperature  $\sim 11$  K

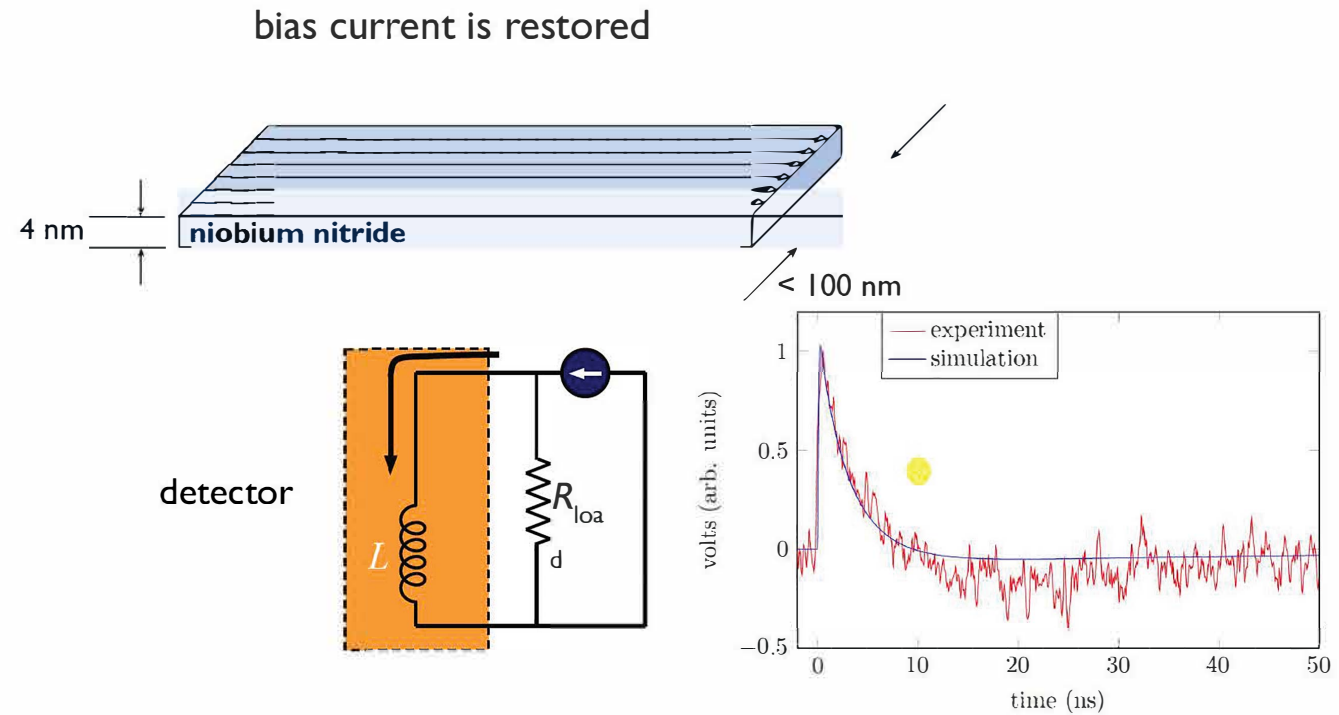

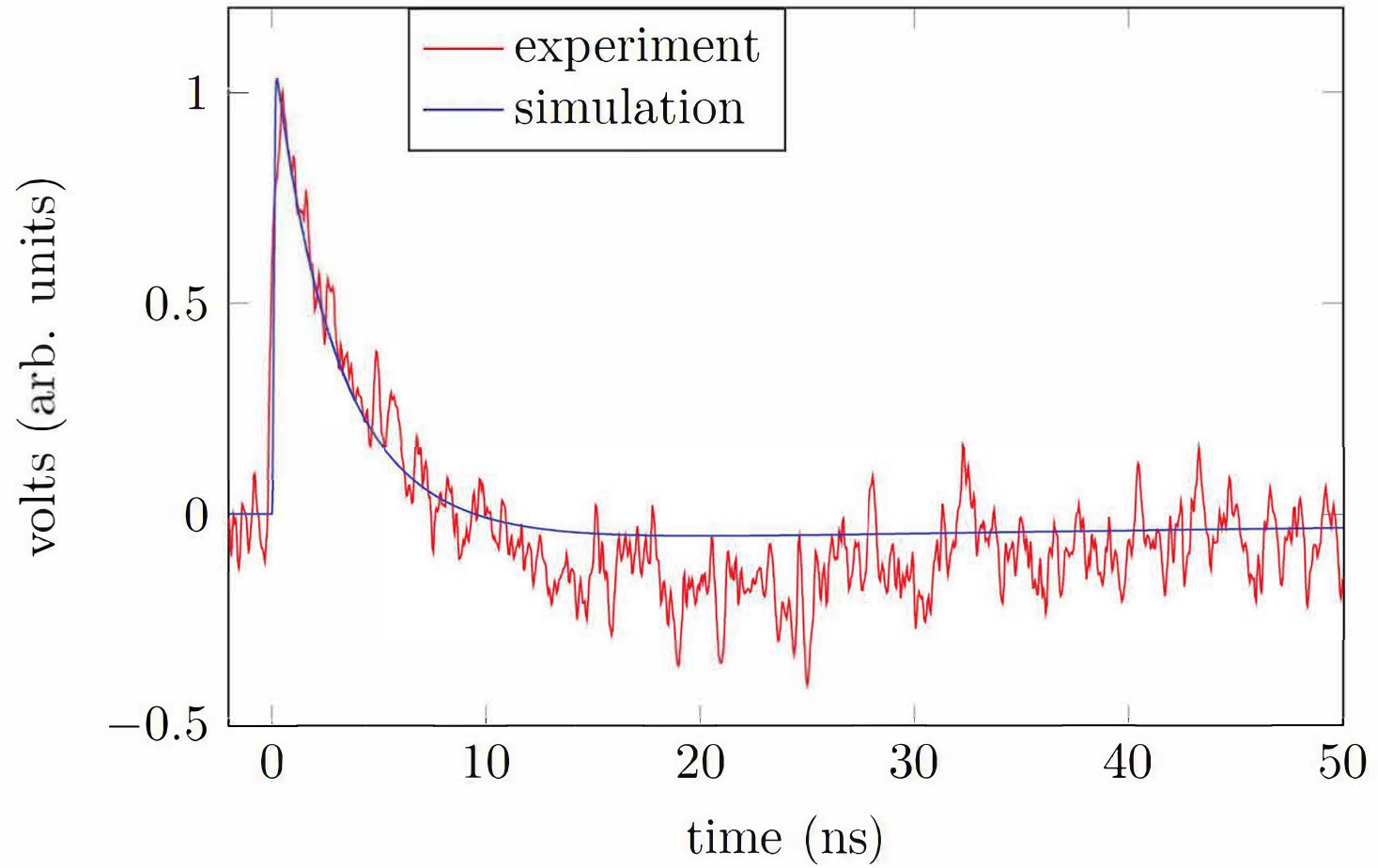

# What Limits Detector Jitter?



# Timing jitter limited by detector geometry

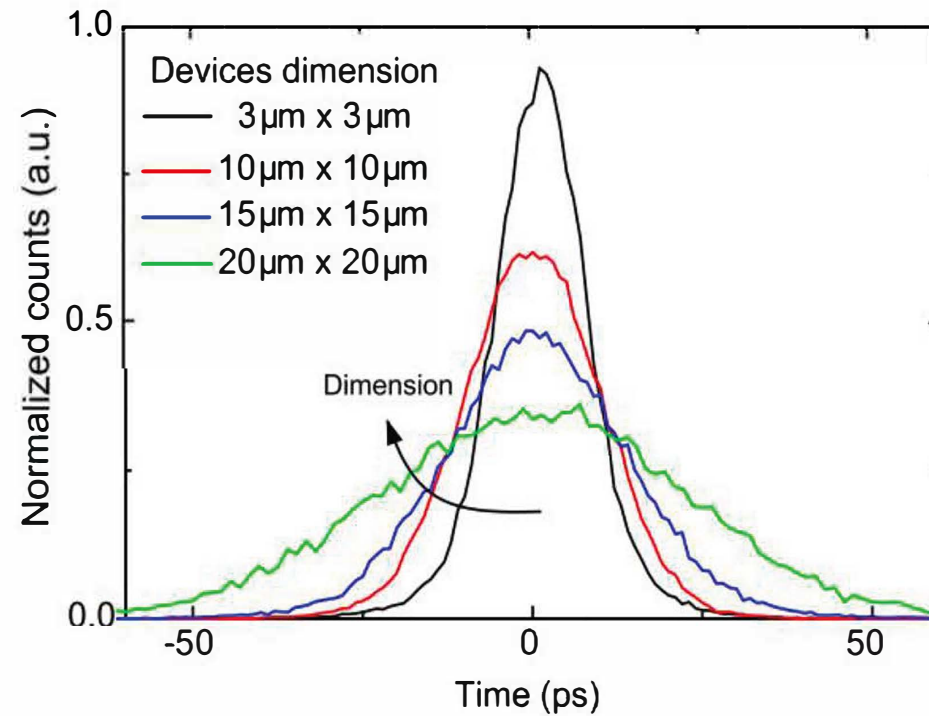

Calandri et al., *Appl. Phys. Lett.*, 109 (15) 152601( 2016).

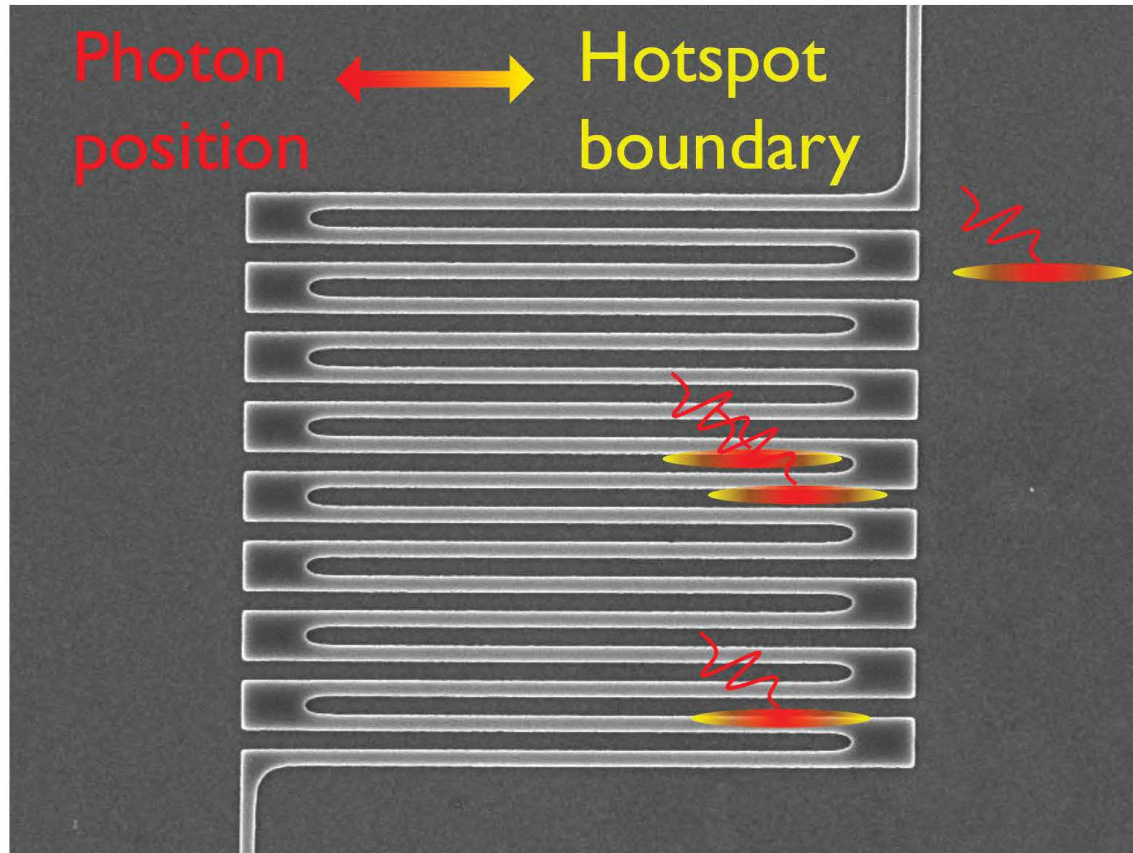

Q: what is the equivalent circuit model of an SNSPD?

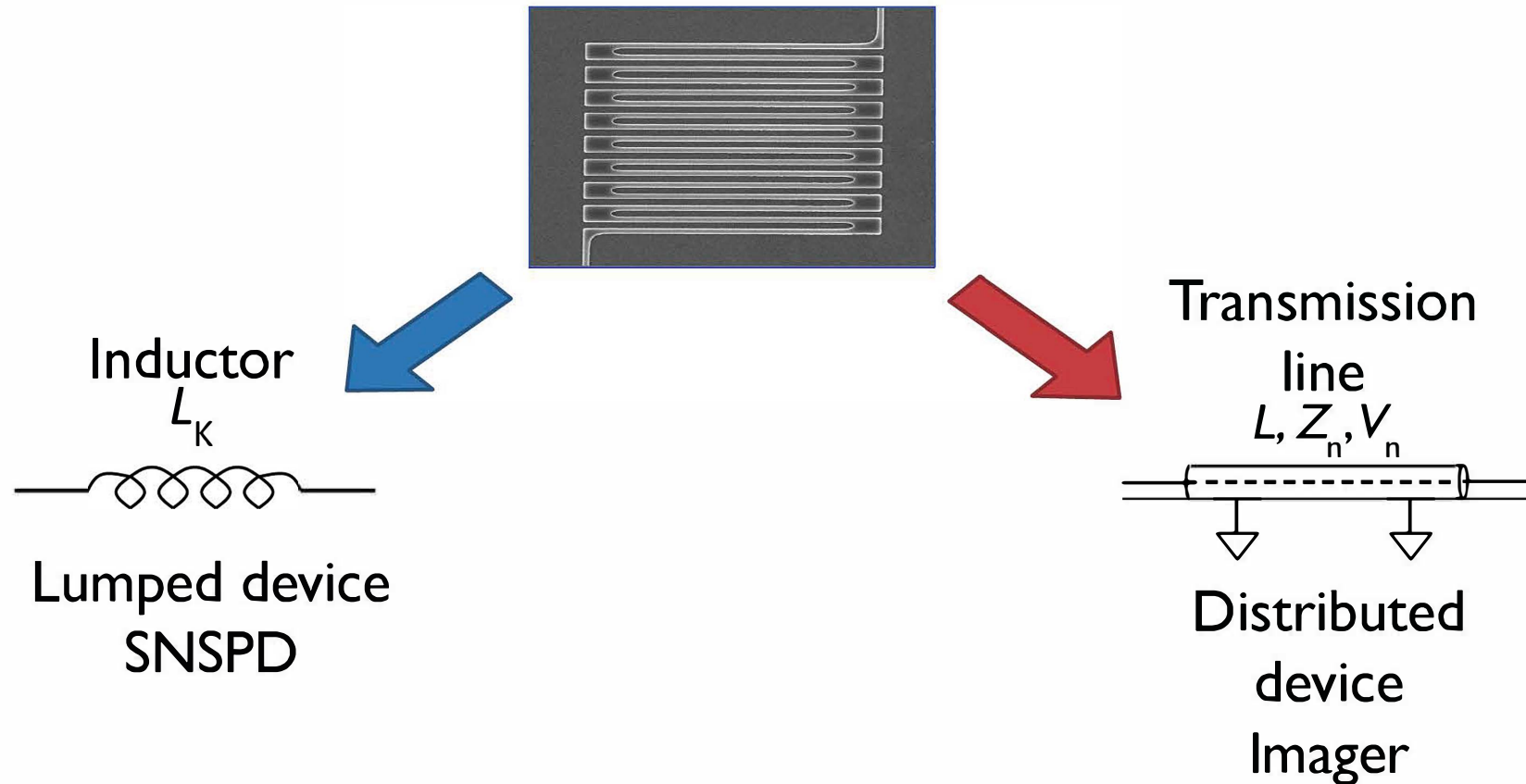

# Slow-wave transmission line

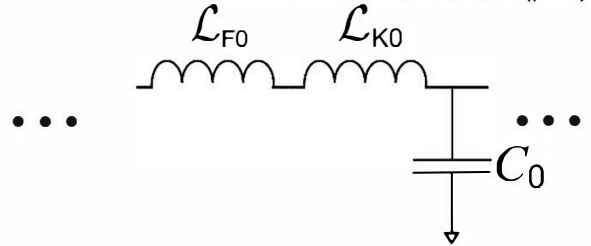
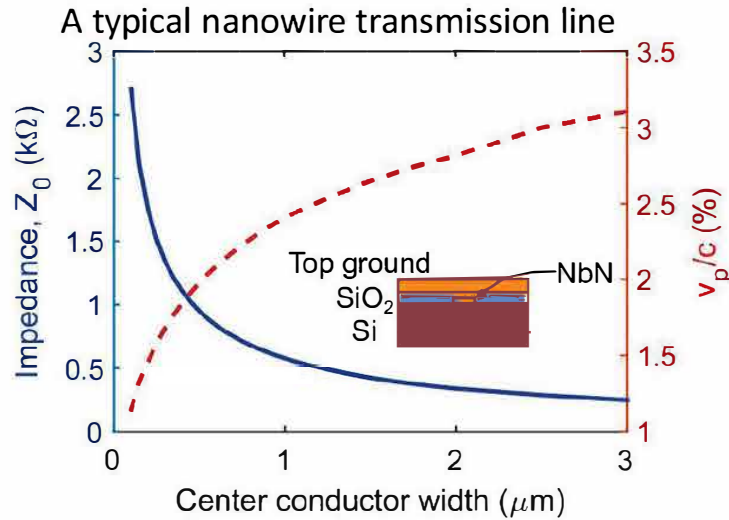

For a  $\sim 5$  nm thick 300 nm wide NbN microstrip,  
 $\mathcal{L}_{K0} \approx 212\mu_0$   $\mathcal{L}_{F0} \approx 0.3\mu_0$   $C_0 \approx 21\epsilon_0$

## Measured group velocities to date

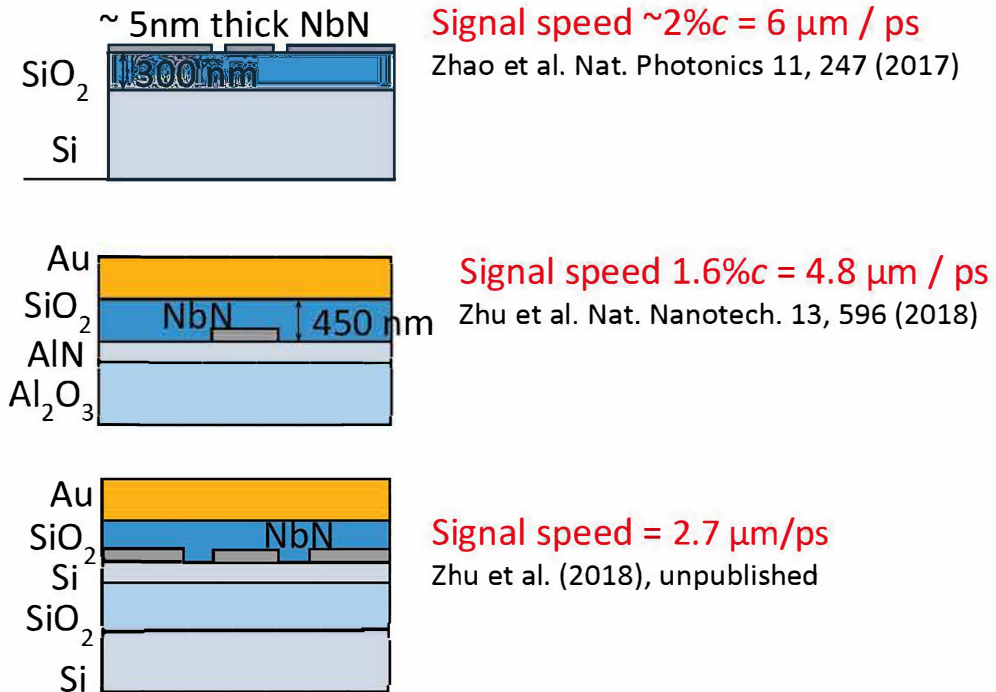

In collaboration with **Daniel Santavicca (UNF)**



# Engineering Microwave Properties of SNSPDs



# Spatial and temporal resolution in a wire

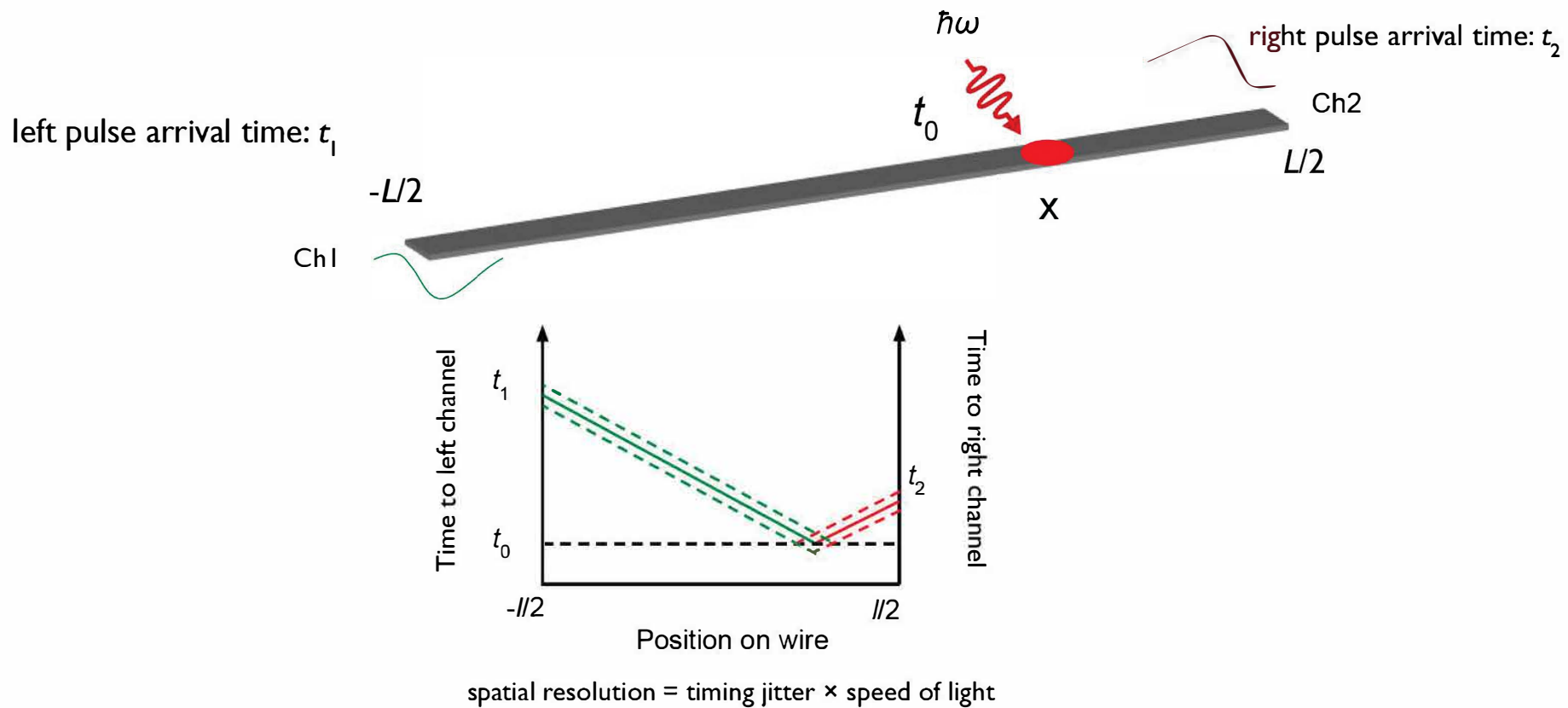

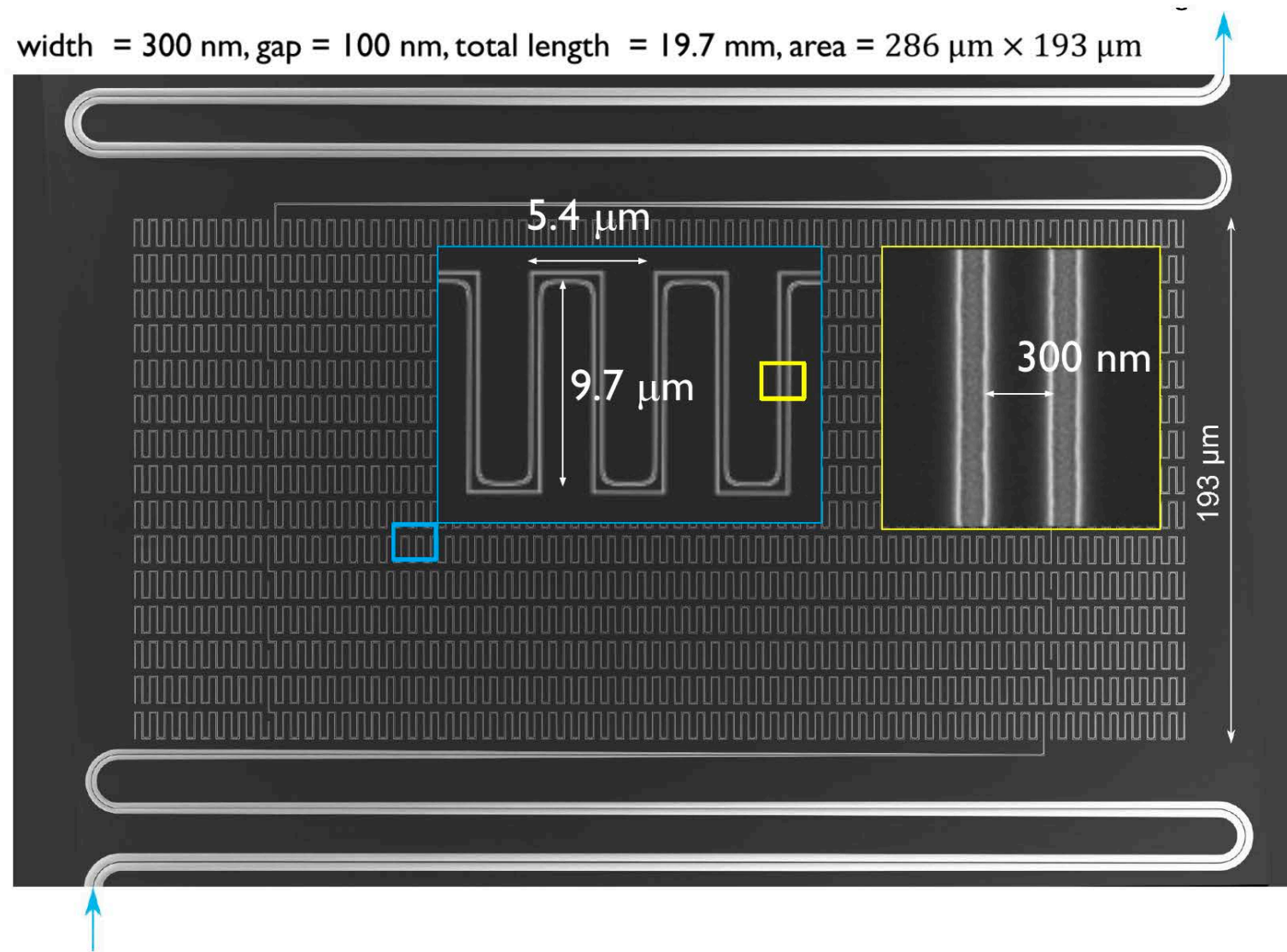

## Two connectors for one imager (>500 pixels)

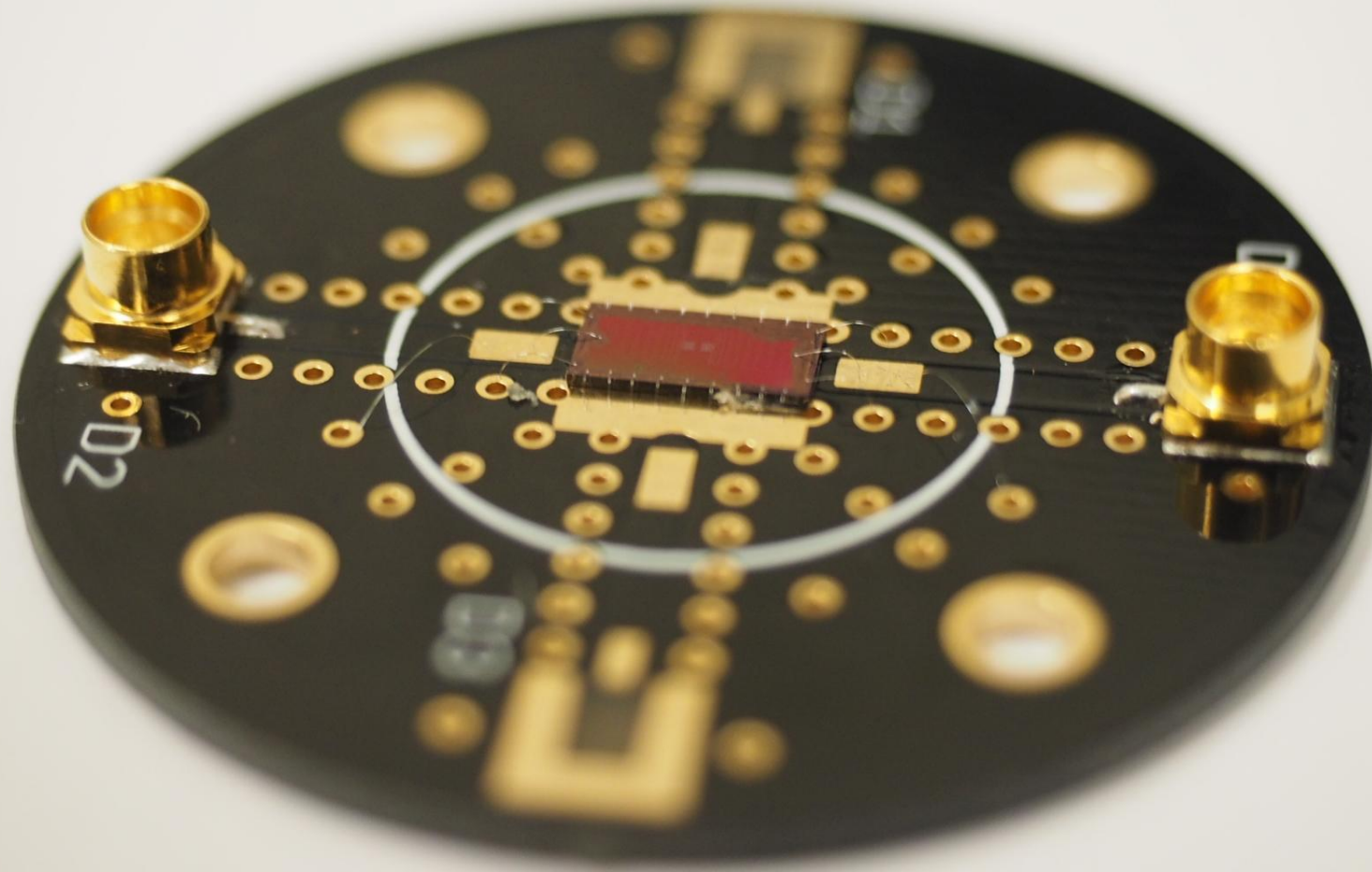

5 mm

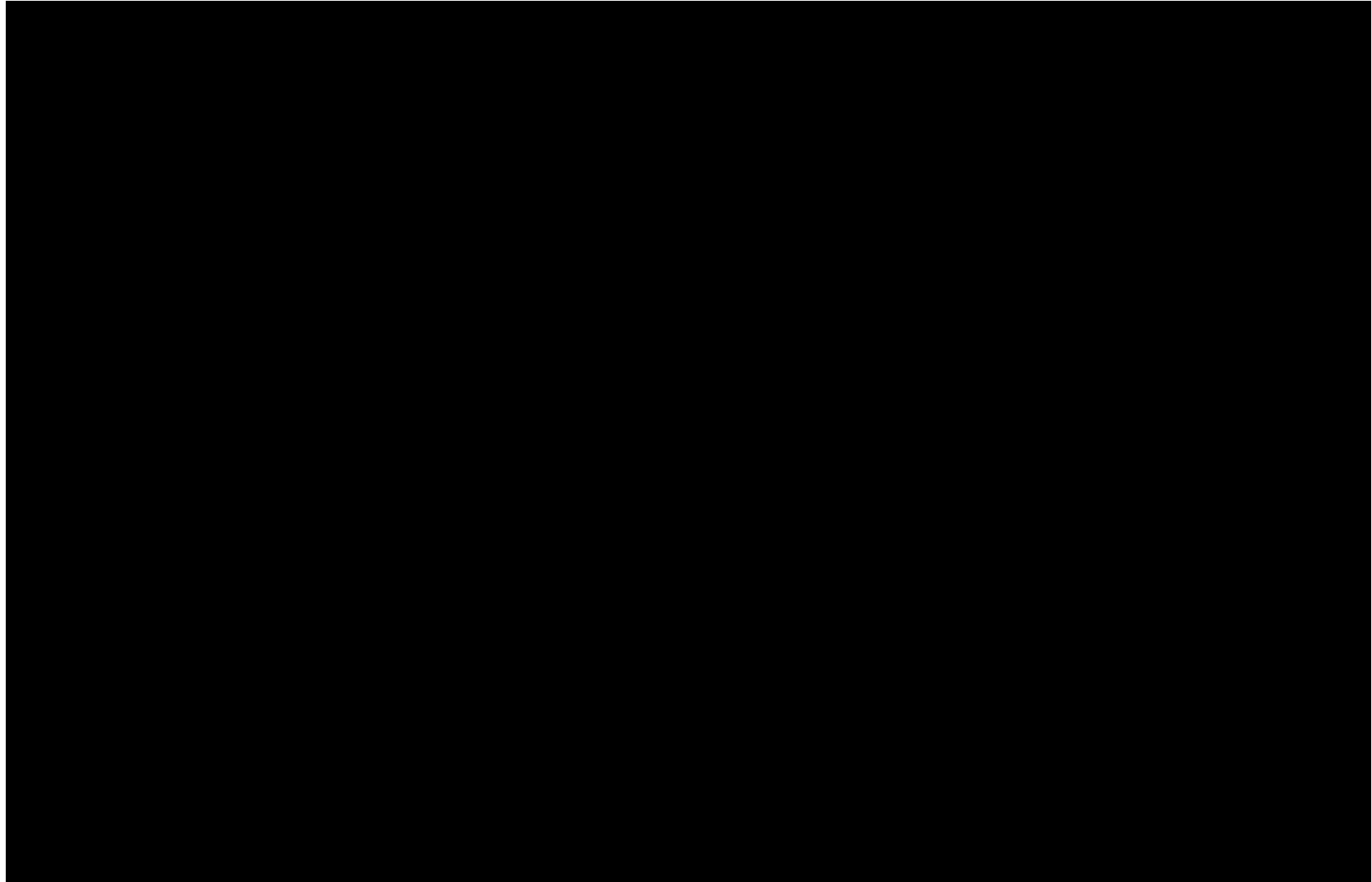

# Detecting two-photon-firing events

16 two-photon firing events among 50,000 photon detection events  
(flood illumination over the entire area)

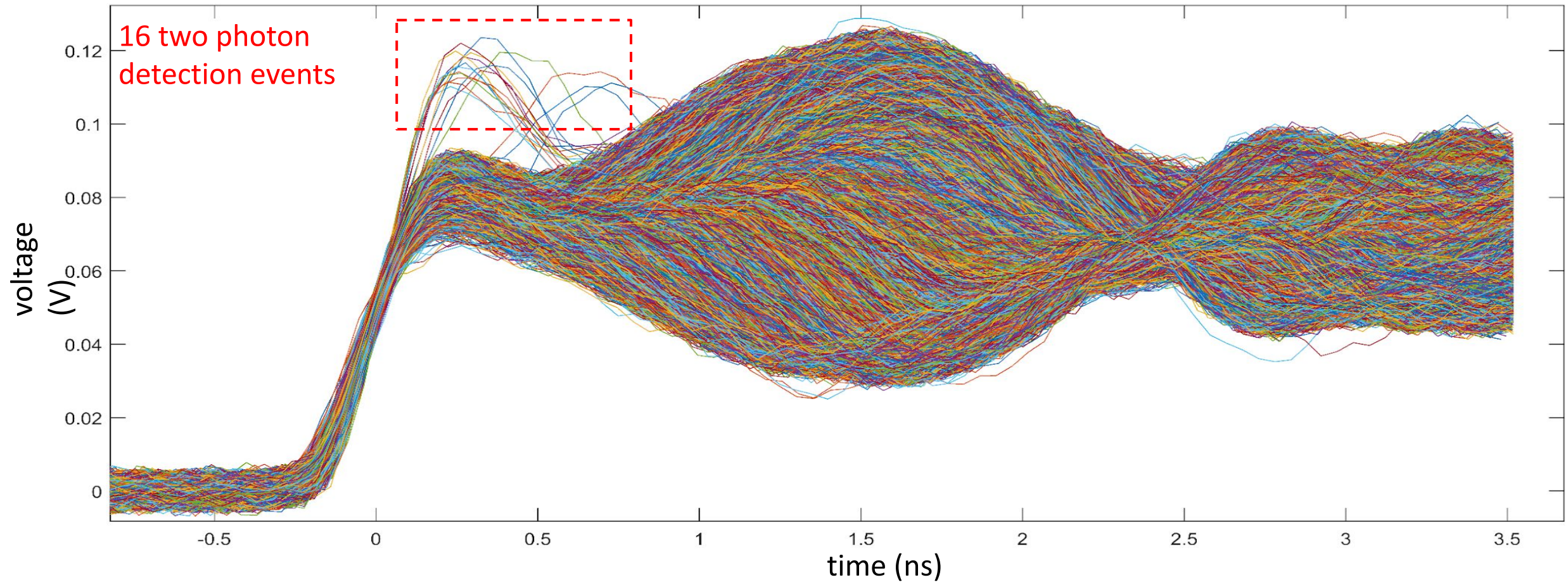

# Multi-photon detection

single photon (1), two photon (6),  
three photon (4), four count (1)

**Photon number resolving!**

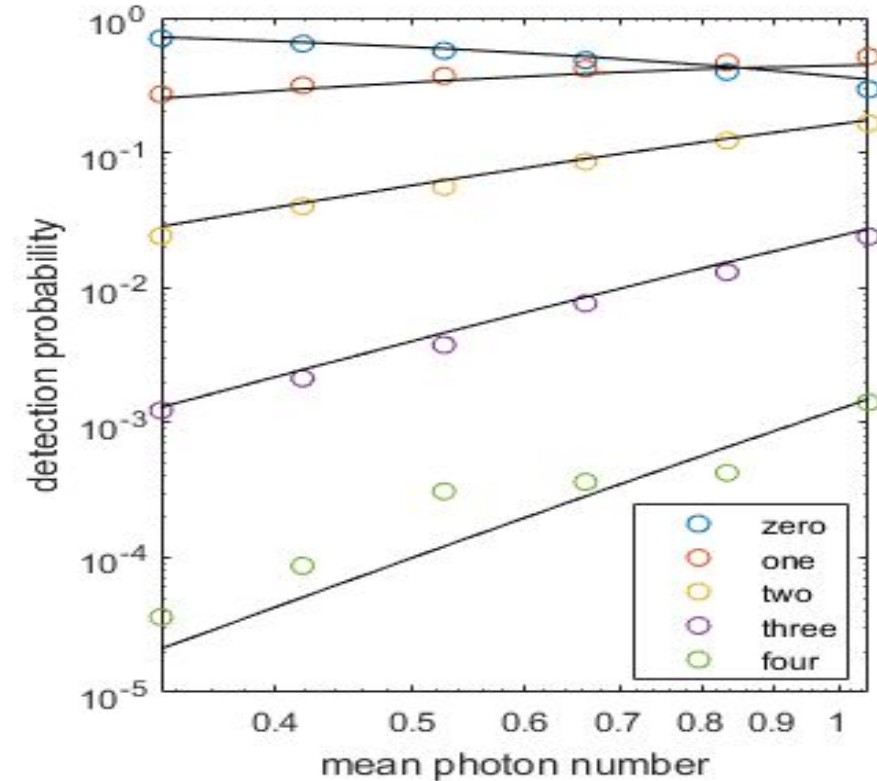
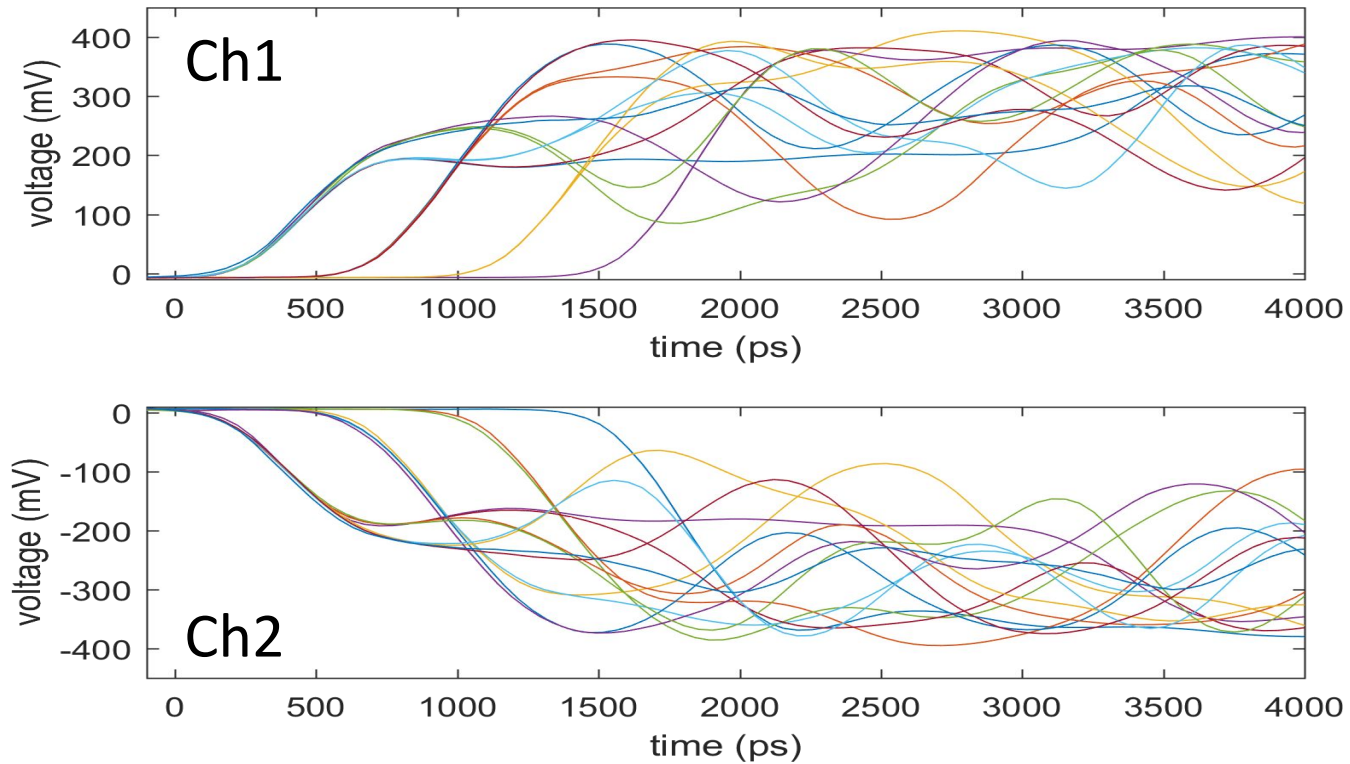

# Increasing output voltage

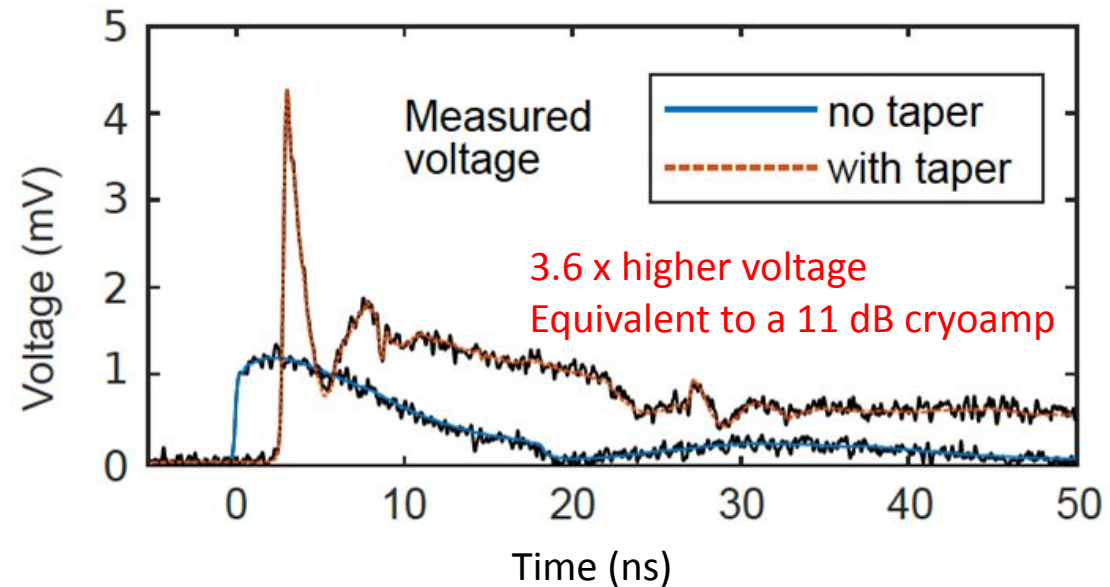
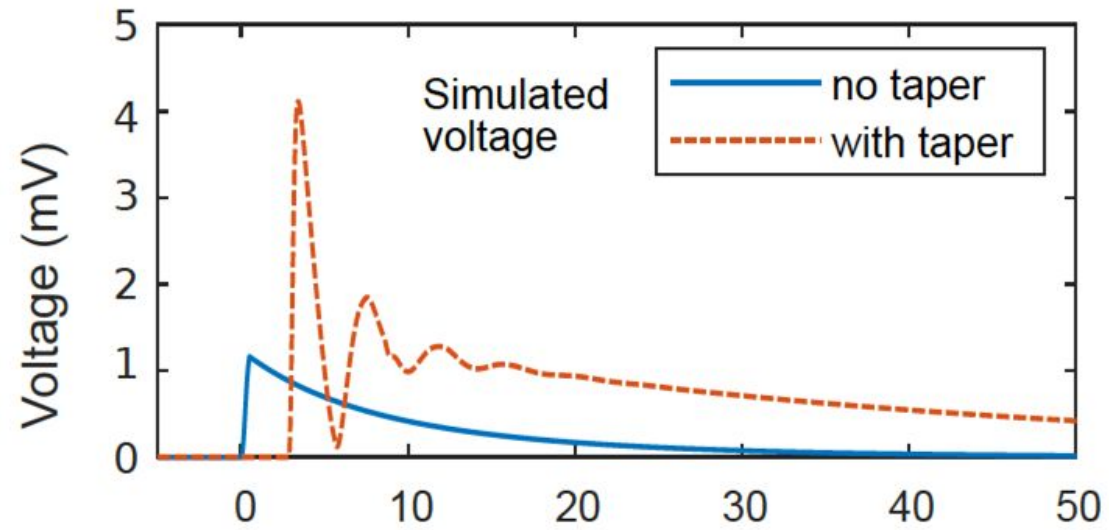
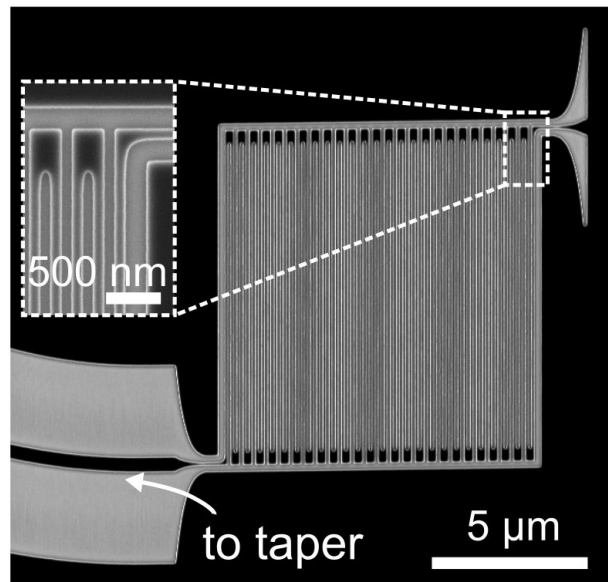
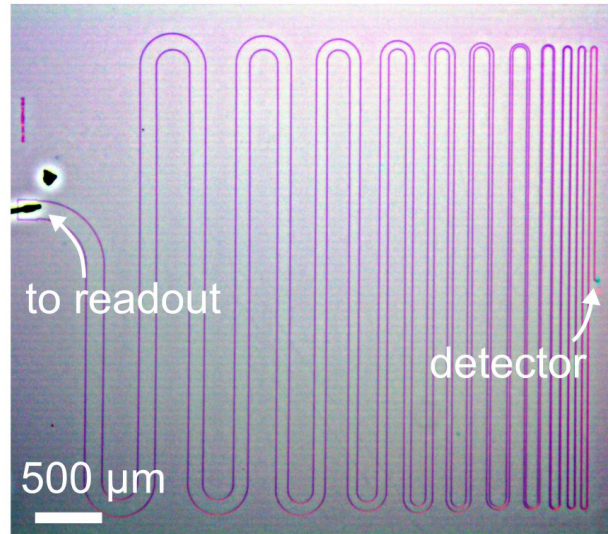



# Photon Number Resolution

## Jitter reduction

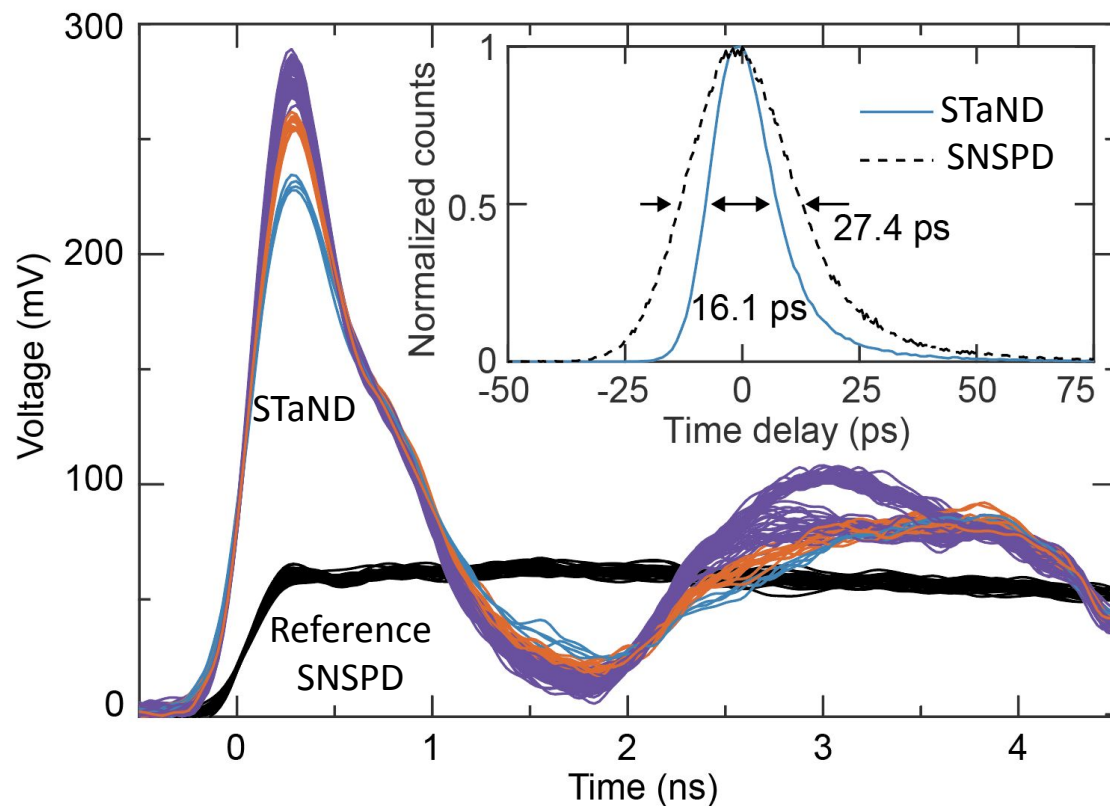

## Photon number resolution

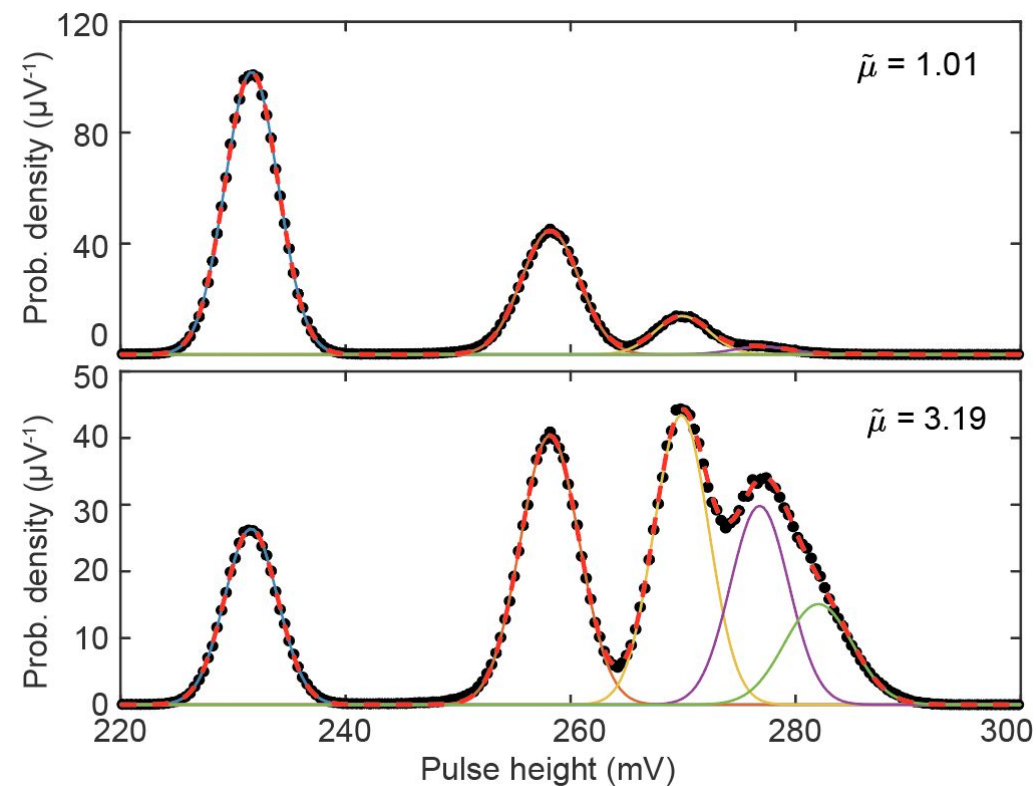

\*Unpublished data

Tapered readout has also enabled:

1. 25 ps jitter in NbN SNSPD without amplifier (measured at JPL)
2. sub-5 ps jitter in WSi using cryogenic amplifiers (Korzhanov et al. CLEO 2018, paper FW3F.3)

# Materials

## Superconducting $a\text{-W}_x\text{Si}_{1-x}$ nanowire single-photon detector with saturated internal quantum efficiency from visible to 1850 nm

Burm Baek,<sup>a)</sup> Adriana E. Lita, Varun Verma, and Sae Woo Nam  
*National Institute of Standards and Technology, 325 Broadway, Boulder, Colorado 80305, USA*

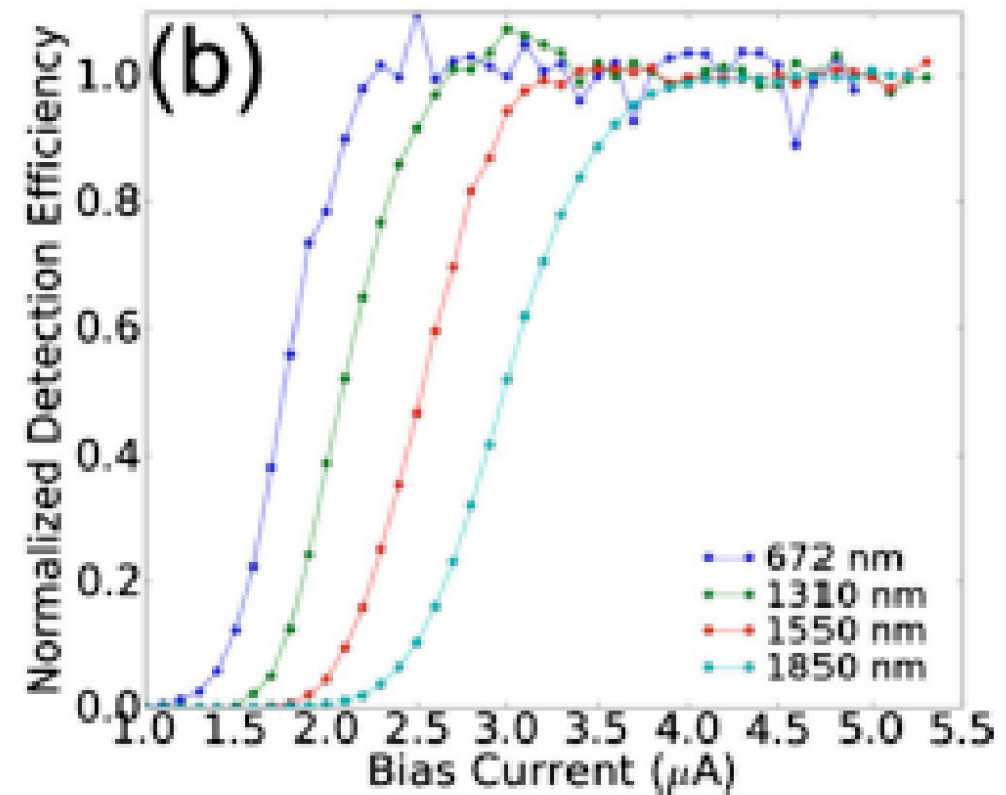
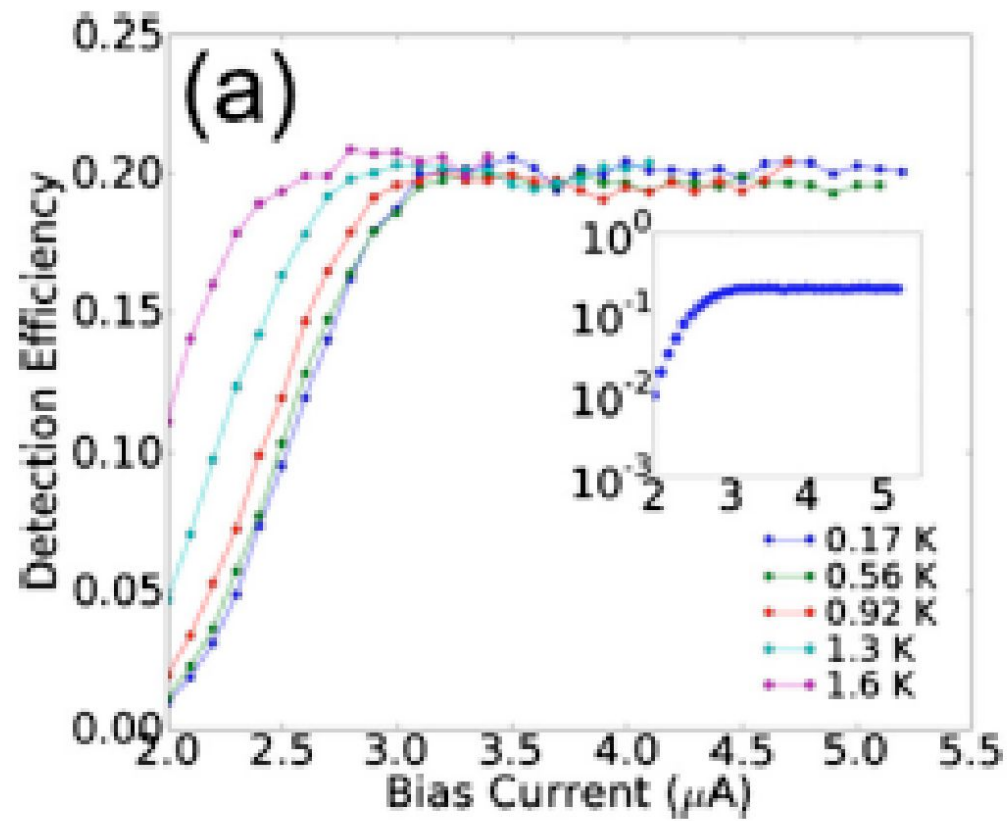

MoSi

### Detector: 50 um diameter active area

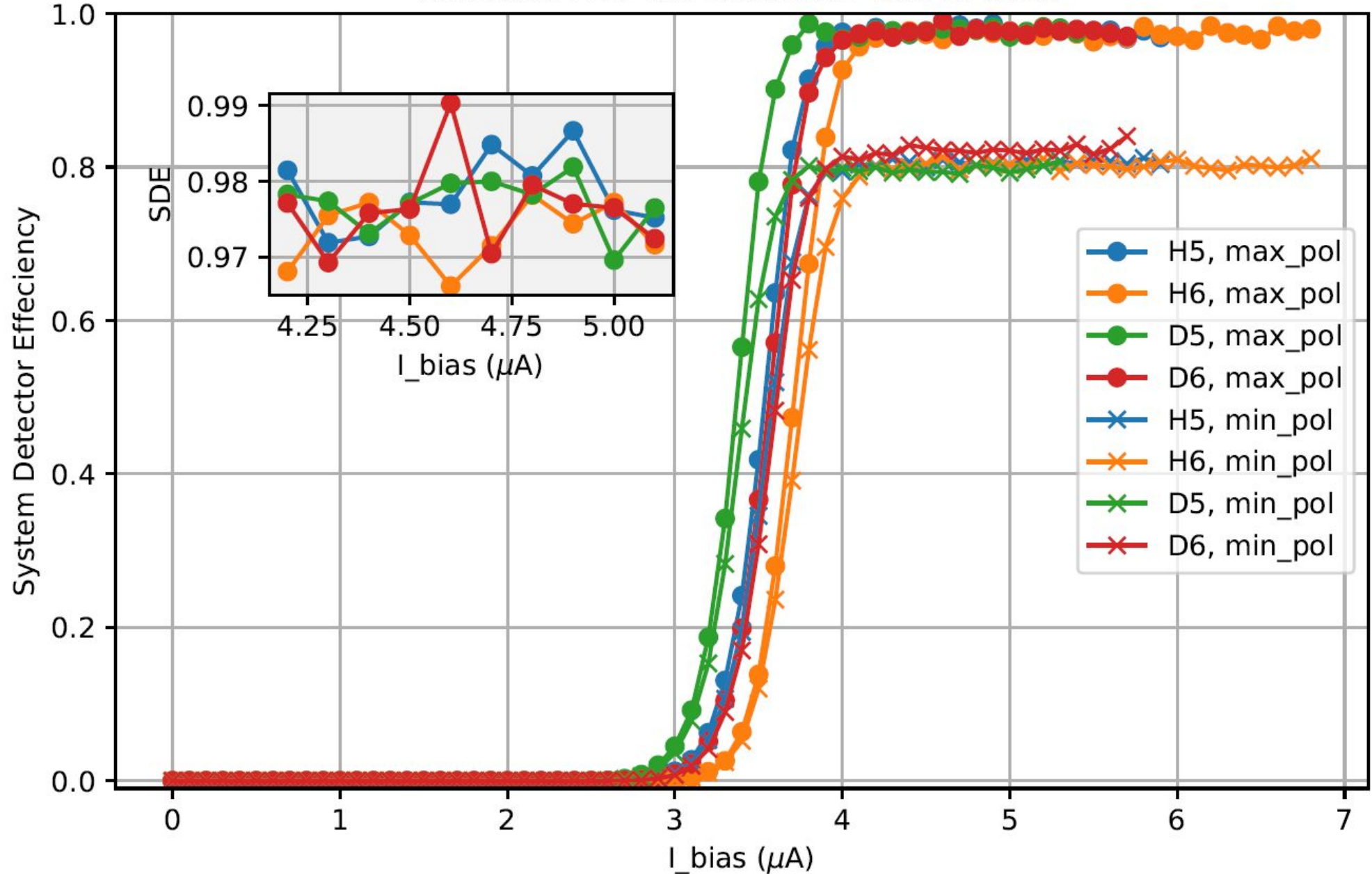

# Do We Even Need Nanowires?

# Operating range of SNSPDs

PHYSICAL REVIEW APPLIED 7, 034014 (2017)

## Single-Photon Detection by a Dirty Current-Carrying Superconducting Strip Based on the Kinetic-Equation Approach

D. Yu. Vodolazov

*Institute for Physics of Microstructures, Russian Academy of Sciences,  
603950 Nizhny Novgorod, GSP-105, Russia*

(Received 14 December 2016; revised manuscript received 30 January 2017; published 23 March 2017)

Using a kinetic-equation approach, we study the dynamics of electrons and phonons in current-carrying superconducting nanostrips after the absorption of a single photon of the near-infrared or optical range. We find that the larger the  $C_e/C_{ph}|_{T_c}$  ratio (where  $T_c$  is the critical temperature of a superconductor and  $C_e$  and  $C_{ph}$  are specific heat capacities of electrons and phonons, respectively), the larger the portion of the photon's energy goes to electrons. The electrons become more strongly heated and hence can thermalize faster during the initial stage of hot-spot formation. The thermalization time  $\tau_{th}$  can be less than 1 ps for superconductors with  $C_e/C_{ph}|_{T_c} \gg 1$  and a small diffusion coefficient of  $D \approx 0.5 \text{ cm}^2/\text{s}$  when thermalization occurs, mainly due to electron-phonon and phonon-electron scattering in a relatively small volume of approximately  $\xi^2 d$  ( $\xi$  is a superconducting coherence length, while  $d < \xi$  is a thickness of the strip). For longer time spans, due to diffusion of hot electrons' effective temperature inside the hot spot decreases, the size of the hot spot increases, the superconducting state becomes unstable, and the normal domain spreads in the strip at a current larger than the so-called detection current. We find the dependence of the detection current on the photon's energy, the location of its absorption in the strip, the width of the strip, and the magnetic field, and we compare this dependence with existing experiments. Our results demonstrate that materials with  $C_e/C_{ph}|_{T_c} \ll 1$  are bad candidates for single-photon detectors due to a small transfer of the photon's energy to electronic system and a large  $\tau_{th}$ . We also predict that even a several-micron-wide dirty superconducting bridge is able to detect a single near-infrared or optical photon if its critical current exceeds 70% of the depairing current and  $C_e/C_{ph}|_{T_c} \gtrsim 1$ .

Korneeva, Y., Vodolazov, D., Florya, I., Manova, N., Smirnov, E., Korneev, A., Mikhailov, M., Goltsman, G., & Klapwijk, T. M. (2018). Single photon detection in micron scale NbN and  $\alpha$ -MoSi superconducting strips. *EPJ Web of Conferences*, 190, [04010].  
<https://doi.org/10.1051/epjconf/201819004010>

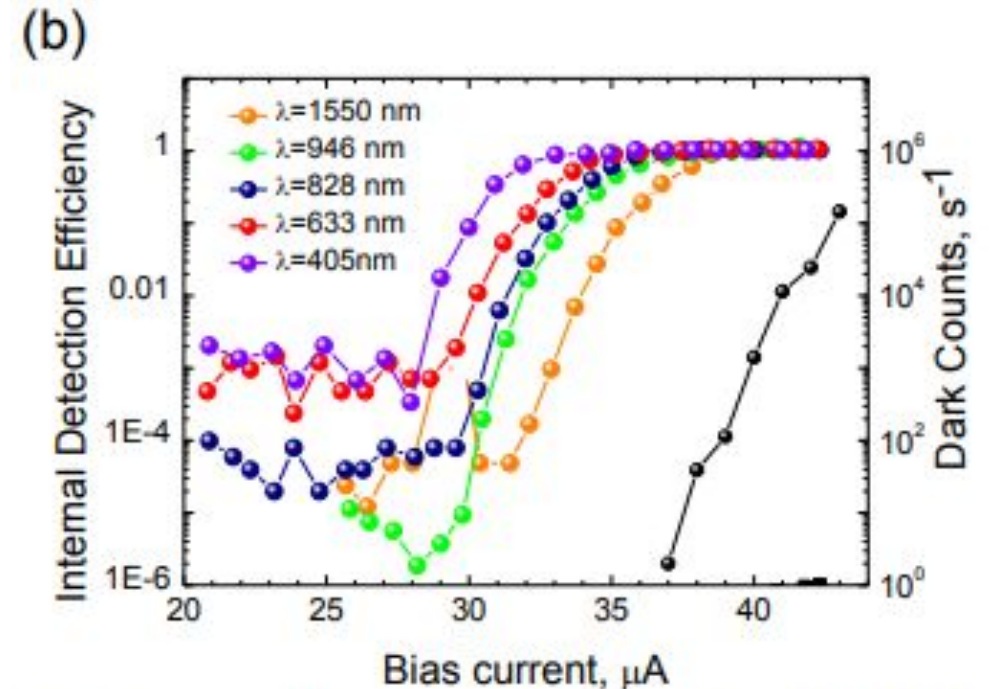



# Single-photon detection in short micro-scale NbN wires

Suggested based on theory work by  
*D. Y. Vodolazov, Phys. Rev. Applied 7, 034014, 2017*

Goltsman's group at MSPU

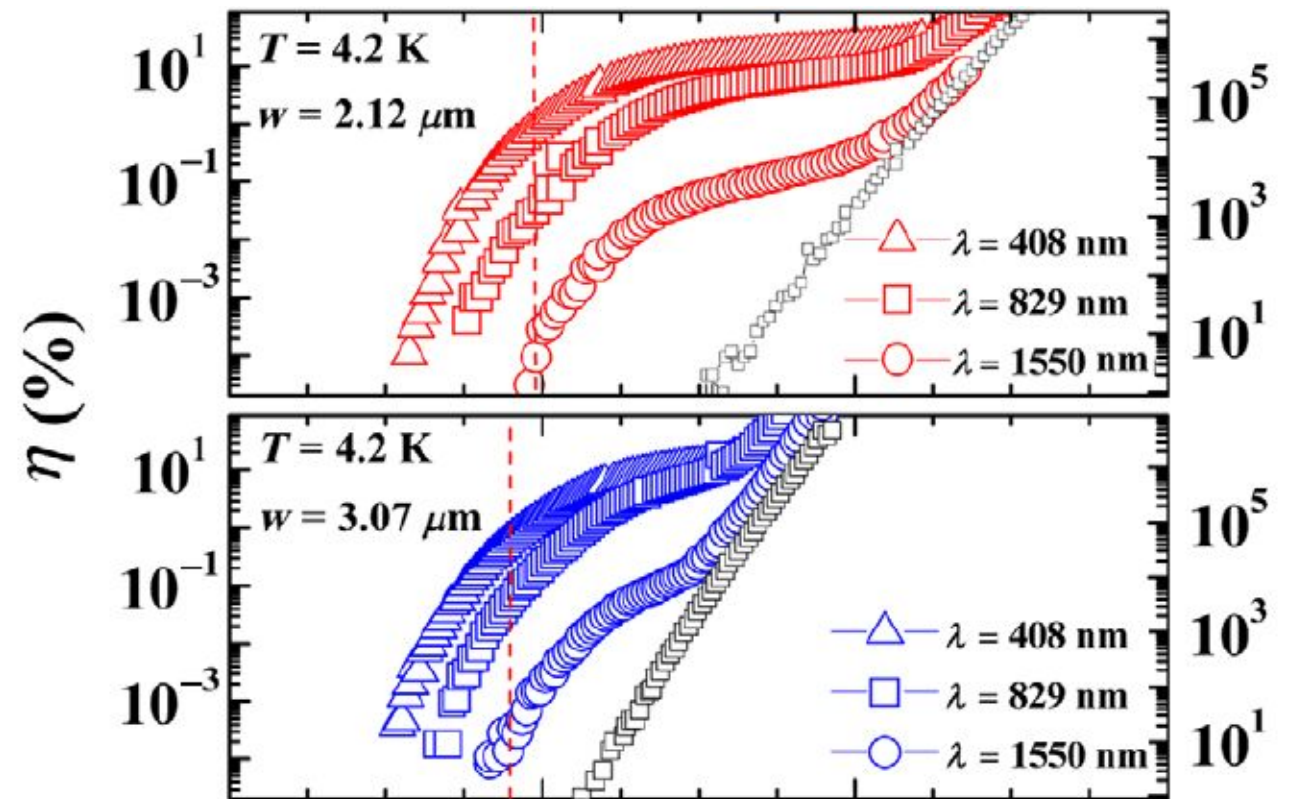
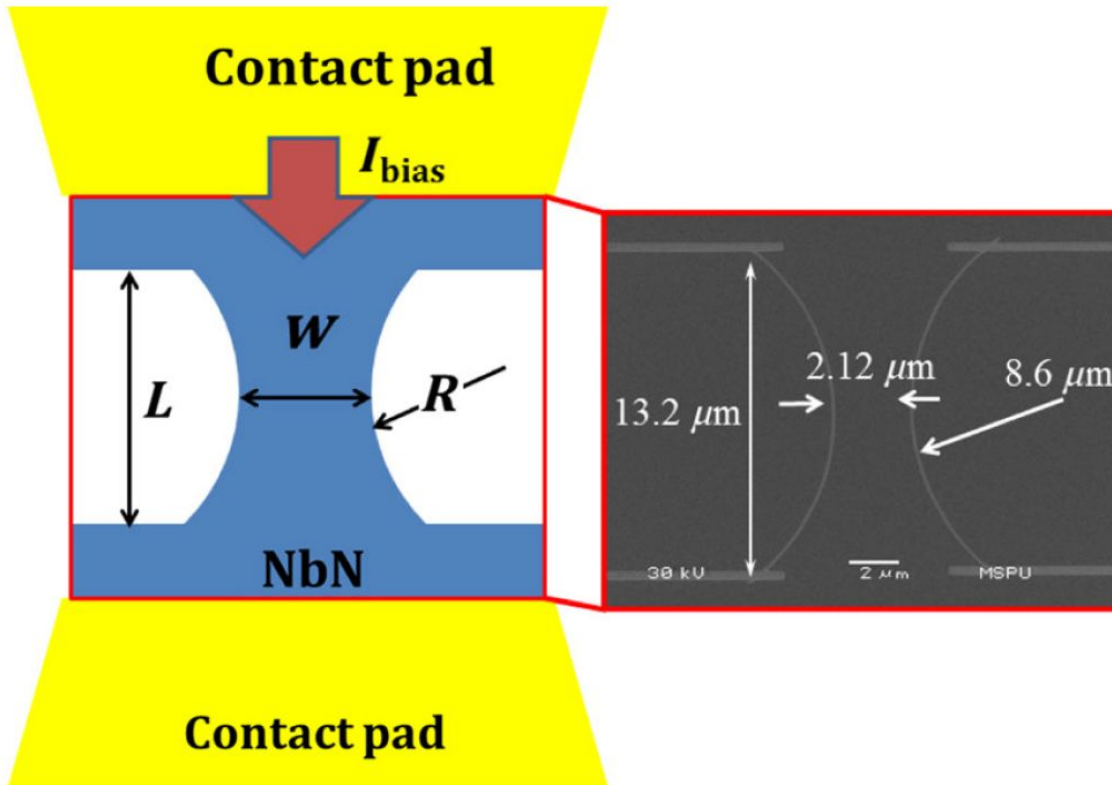

*Yu. P. Korneeva and et. al., Phys. Rev. Applied 9, 064037, 2018*

# Silicon-rich WSi microwires

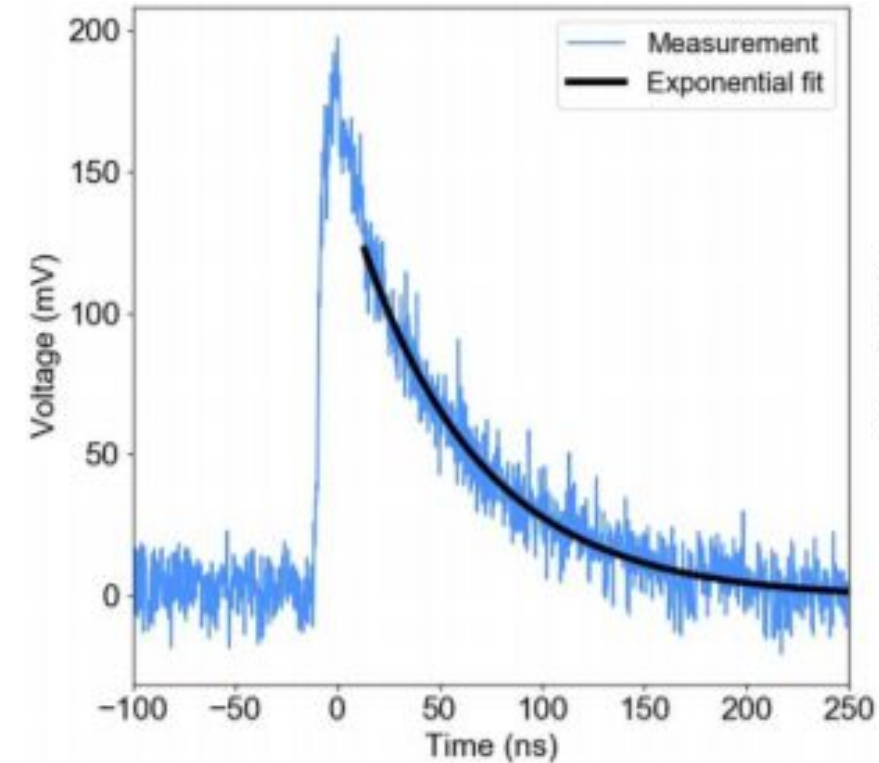
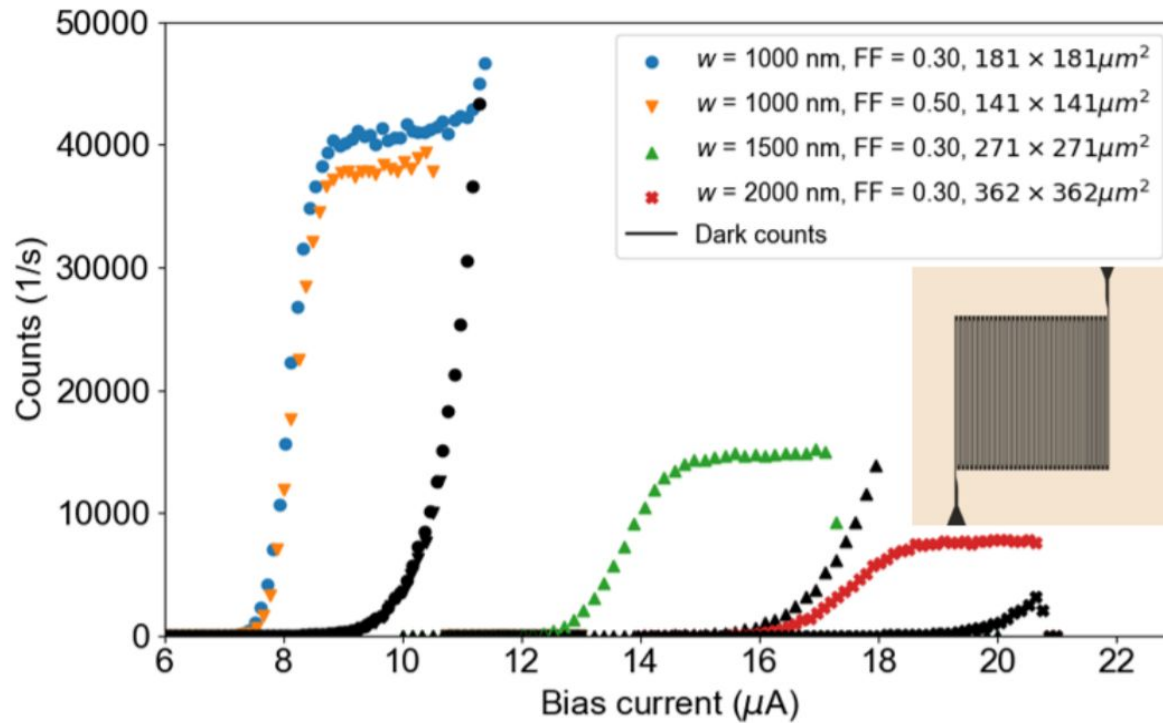

- 2-3 nm WSi microwires by e-beam and photolithography
- Width: 400 nm - 2  $\mu\text{m}$
- Wavelength: 1330 and 1550 nm
- Operating temperature: 0.8 K

*J. Chiles and et al, Appl. Phys. Lett. 116, 242602 (2020)*





# Large-area microwire MoSi single-photon detectors

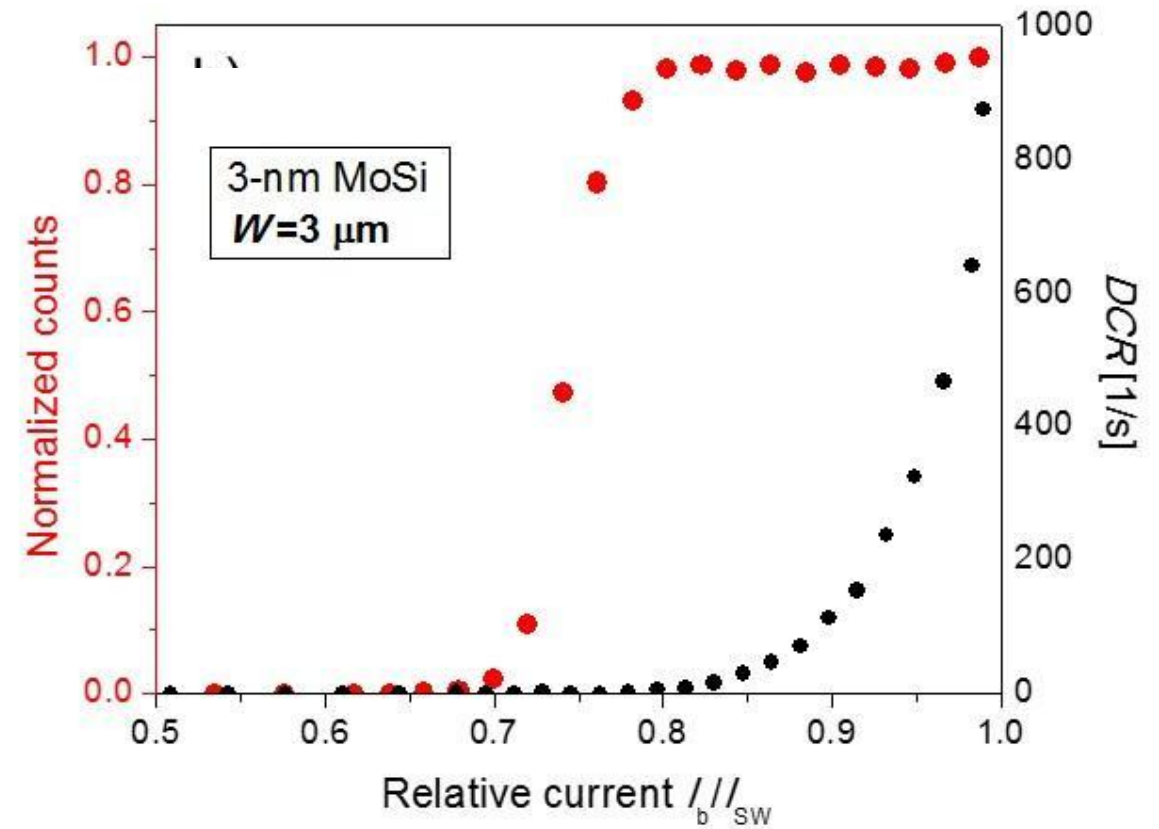
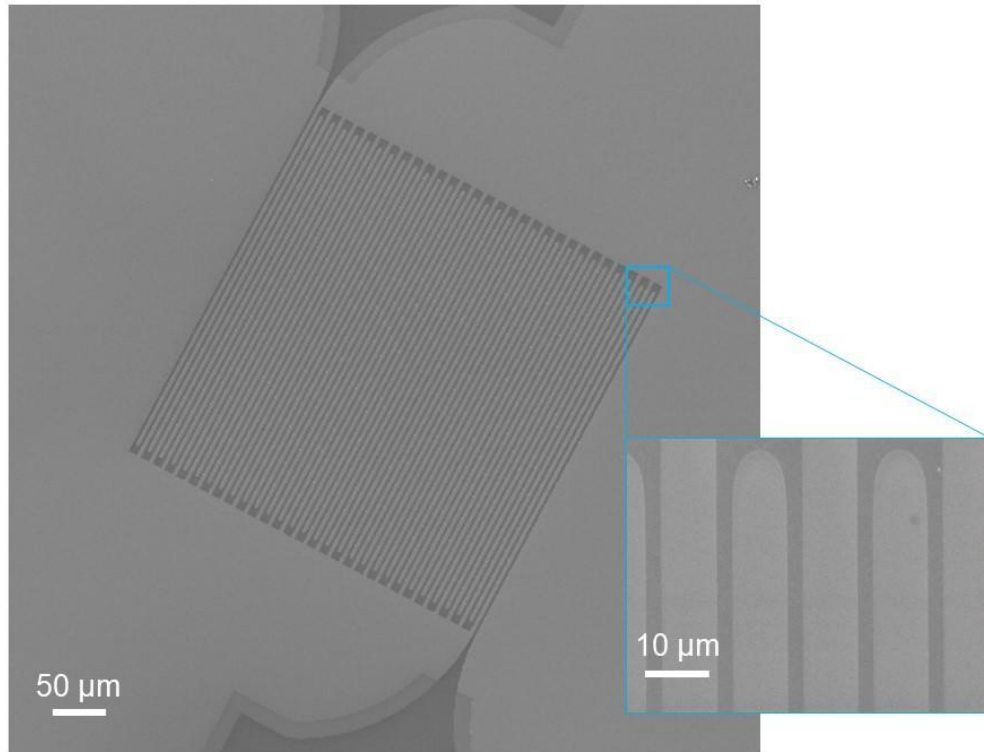

Thin 3-nm MoSi film, up to 3  $\mu\text{m}$ -wide, operating  $T = 0.3 \text{ K}$ ,  $\lambda = 1550 \text{ nm}$

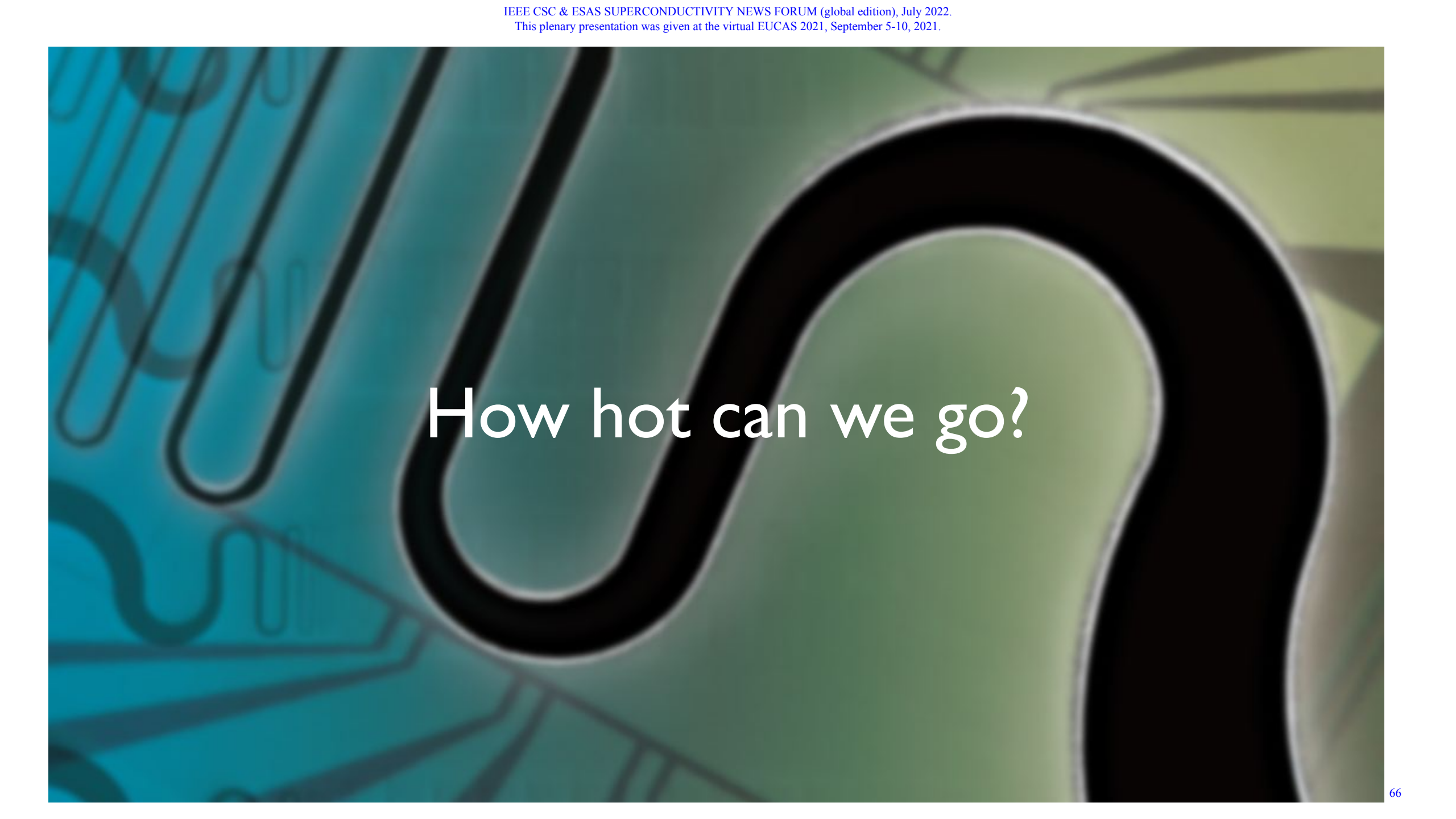

How hot can we go?

# Operating Temperature of Superconducting Detectors

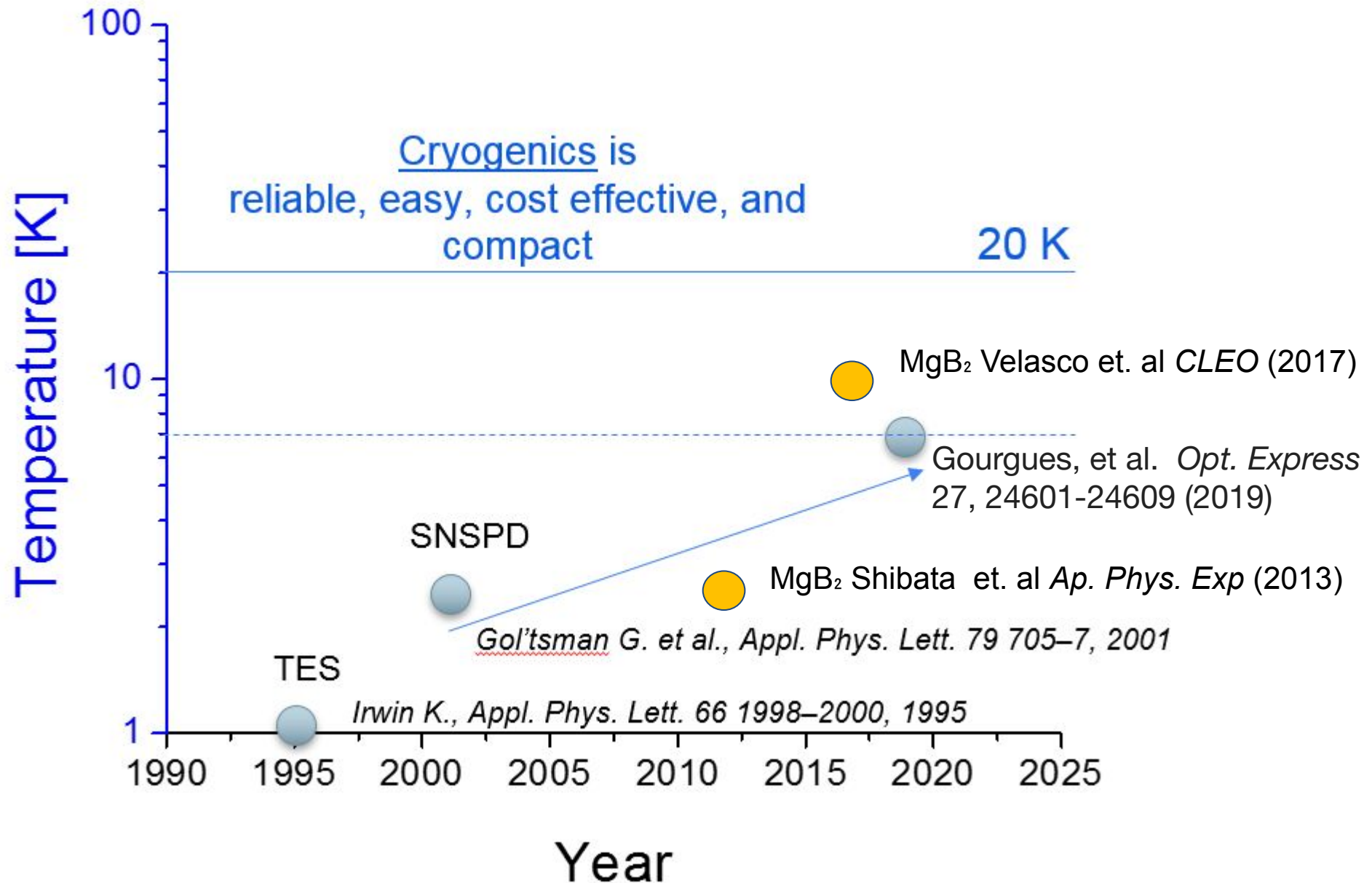

# Past Work on Single-Photon Detection with $\text{MgB}_2$

Hiroyuki Shibata et al  
2013 Appl. Phys. Express  
6 023101 (2012)

4.2K testing  
~ 225 nm wires  
1550 nm light  
 $T_c \sim 20$  K

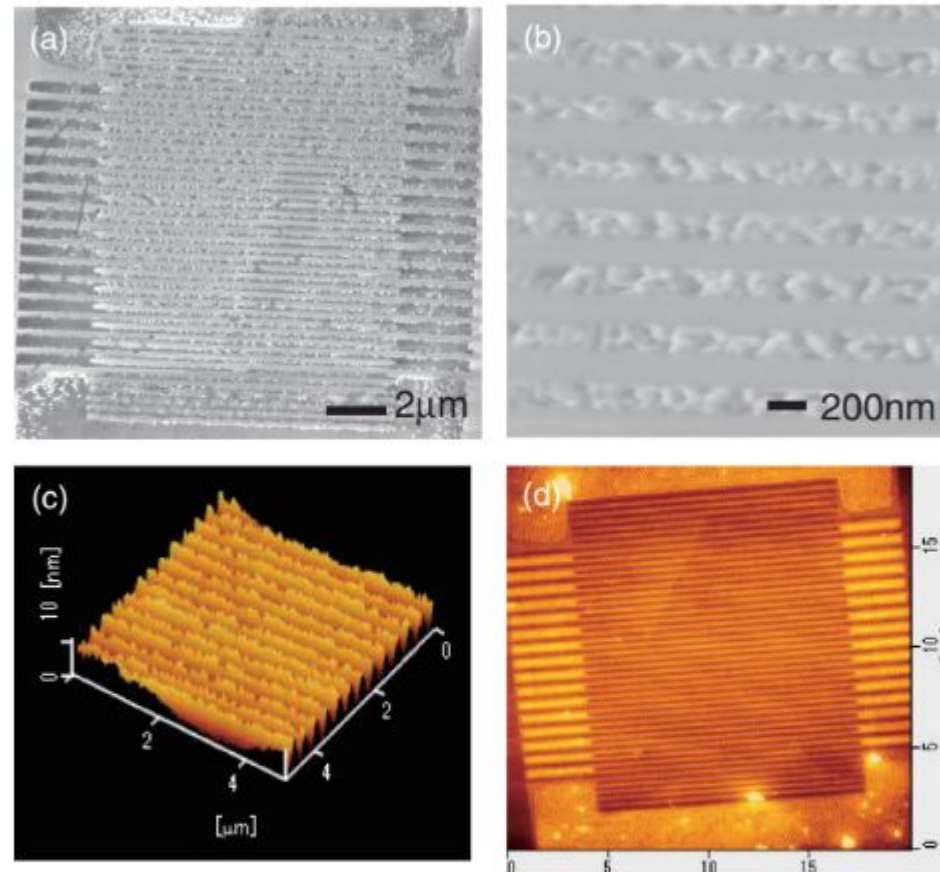

**Fig. 2.** (a) Scanning electron micrograph, (b) enlarged view, (c) atomic force microscopy 3D image, and (d) atomic force microscopy image of  $10 \times 10 \mu\text{m}^2$   $\text{MgB}_2$  meander pattern with the line width of 135 nm and the space width of 165 nm.

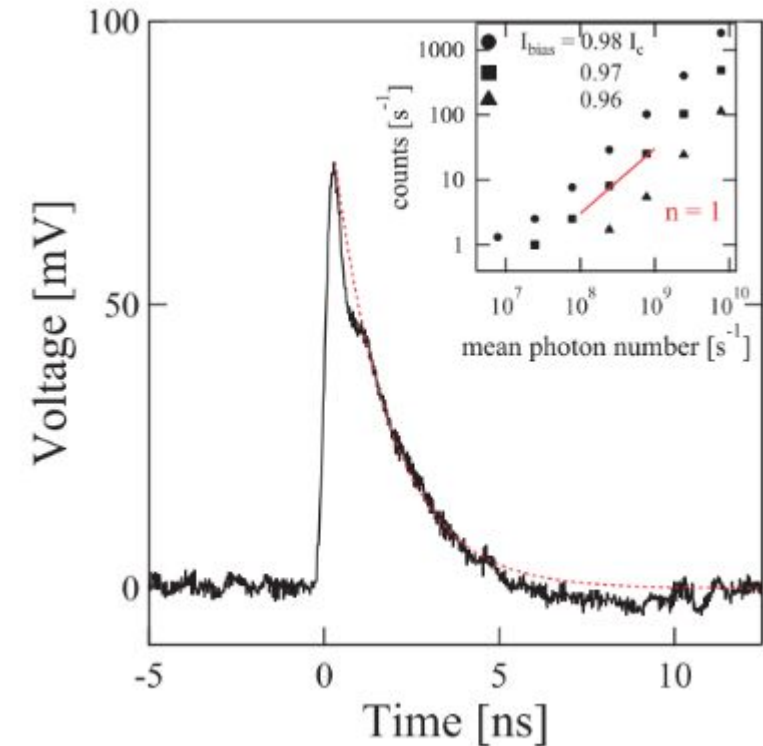

# MgB<sub>2</sub> films

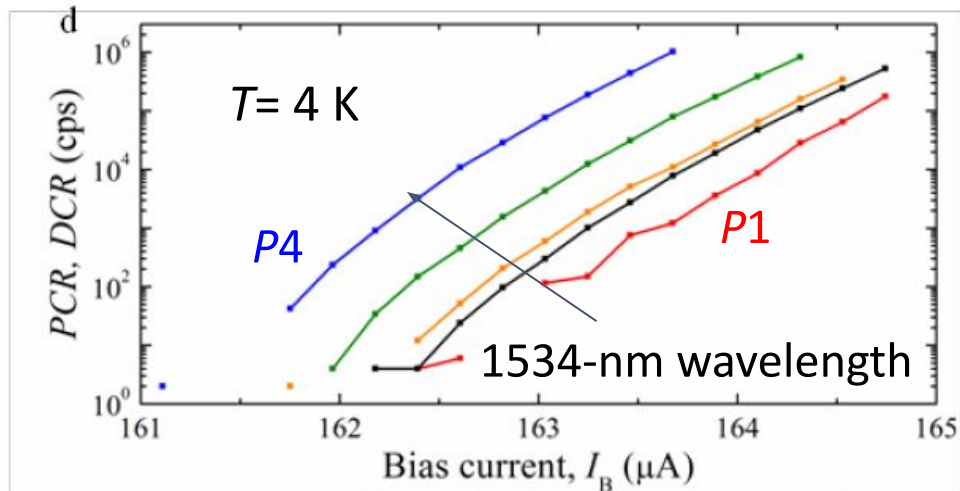

Roughness (RMS)       $T_C$       Thickness

Ideal	< 1 nm	40 K	5 nm
MBE	<0.35 nm	10 K	5 nm
HPCVD	2-4 nm	39 K	6 nm

F. Marsili, CLEO 2015, conference slides

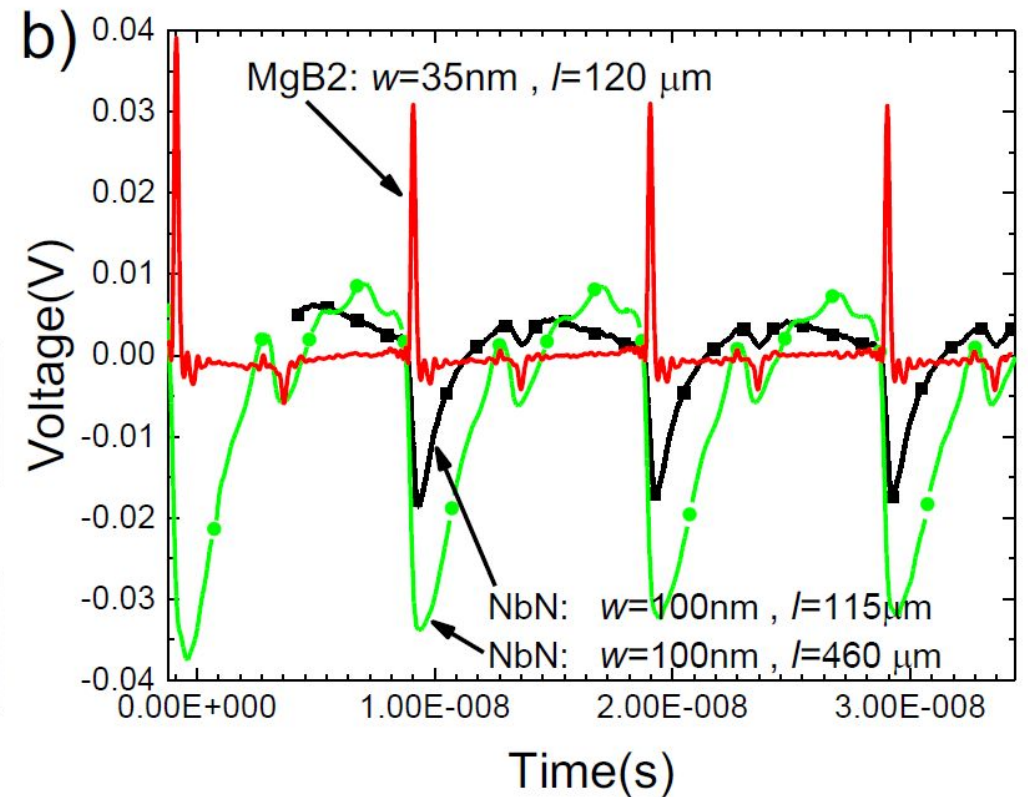

S. Cherednichenko, and *et.al.*, arXiv:1911.01652

- Sub-ns reset time
- $T_C \sim 40$  K

**Single-photon detection at 20 K never demonstrated**

# DC characterization

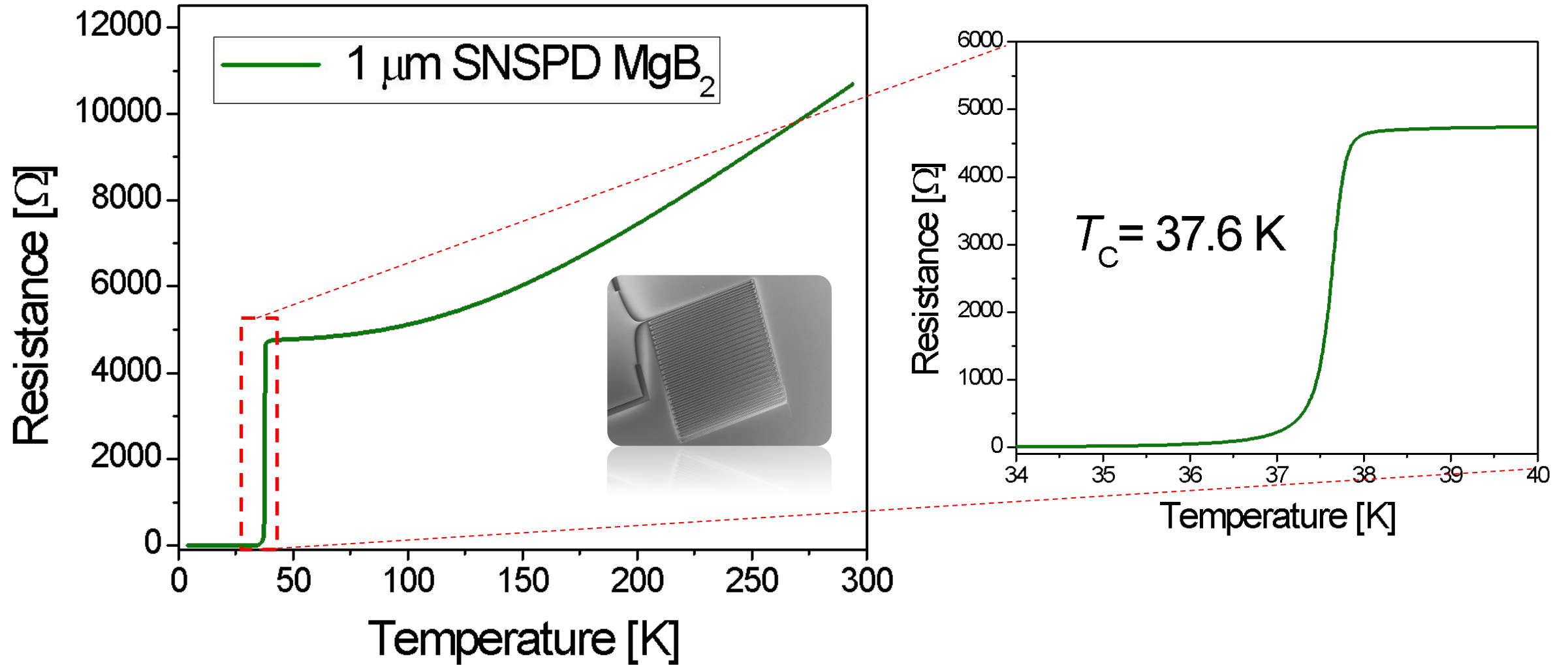

# Pulse, linearity, timing jitter

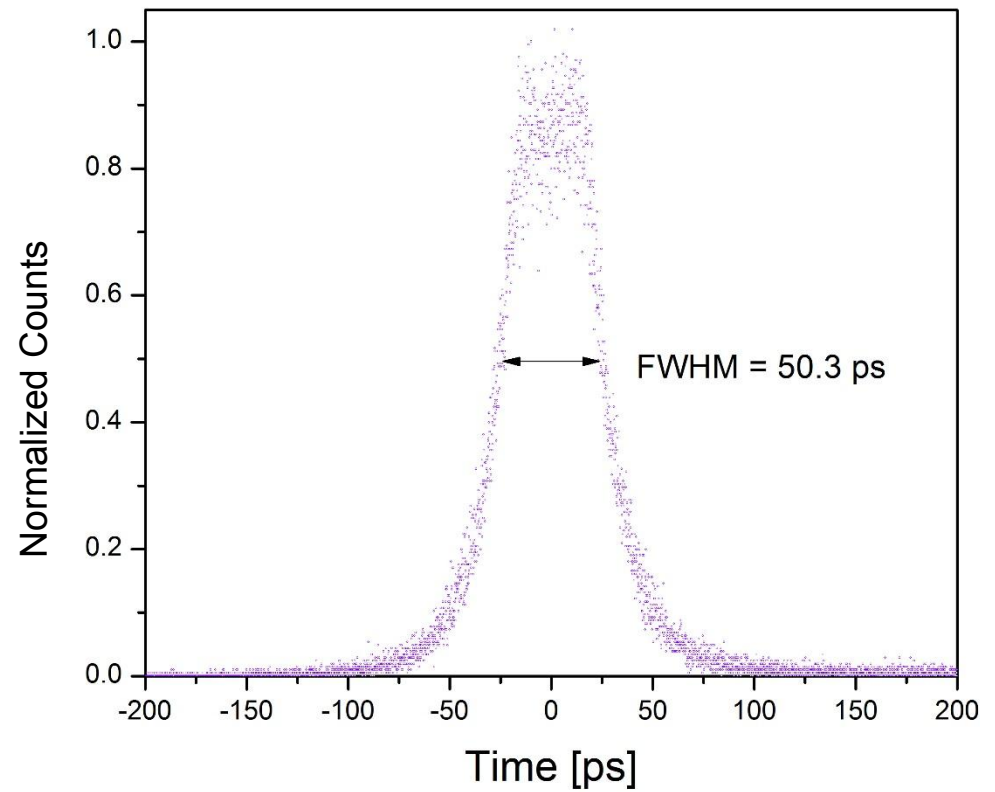
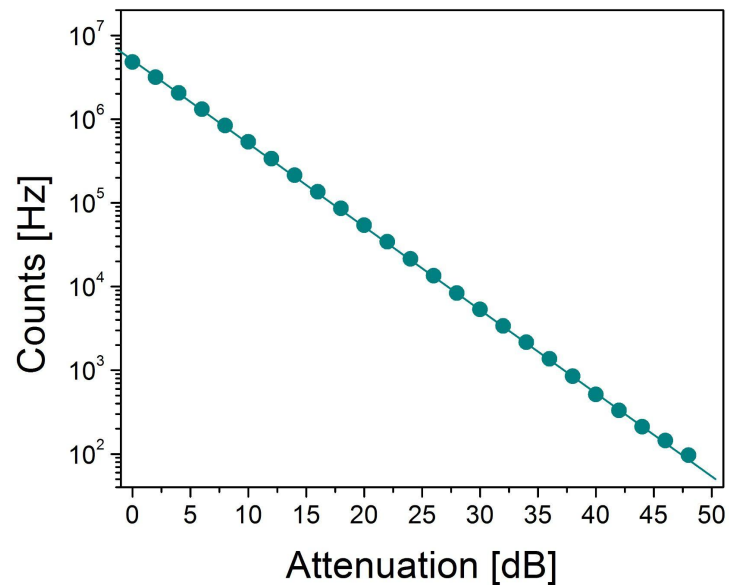
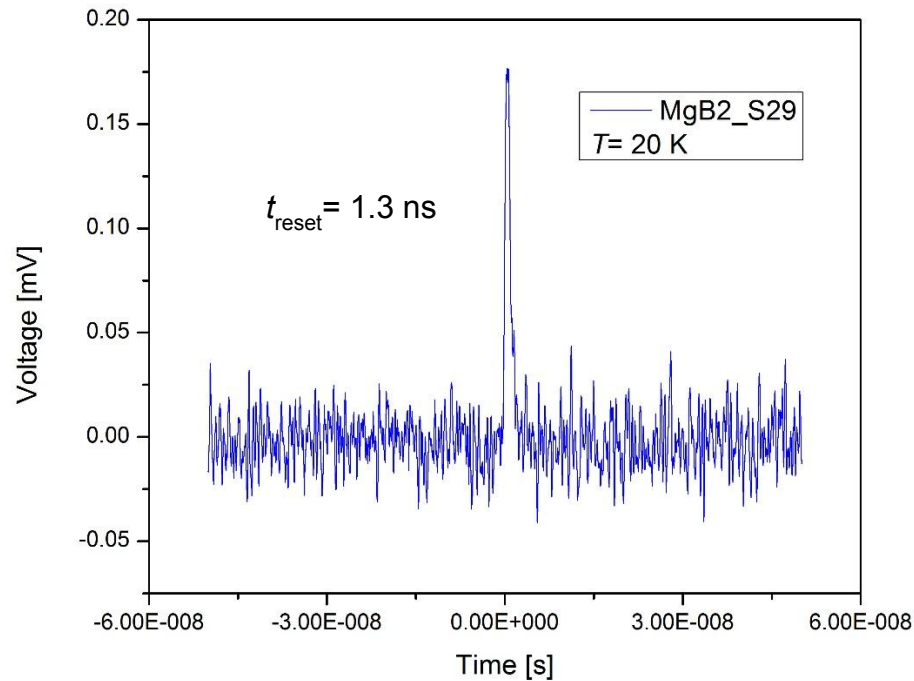

$T = 20 \text{ K}$

$W = 1 \mu\text{m}$

$\lambda = 1550 \text{ nm}$

# What Else Can a Nanowire Do for Us?



# Josephson Junctions: Solving most problems

- SQUID
  - Magnetic sensors
  - Qubits
- SFQ<sup>[1][2]</sup>
  - Ultrafast computing
  - Ultralow power

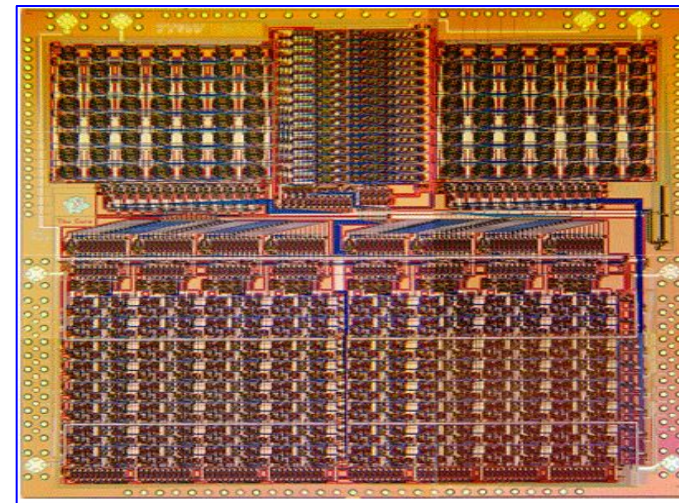
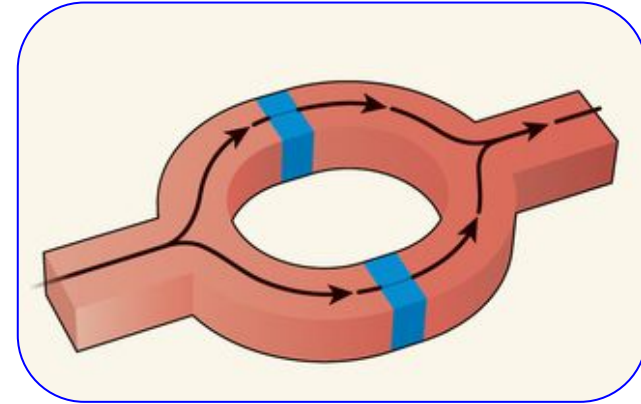

(NGST/SUNY-Stony Brook/JPL)

[1] Likharev, K. K. (2012). *Physica C: Superconductivity*, 482, 6–18

[2] Volkmann, M. H., et. al. (2013) *Superconductor Science and Technology*, 26(1), 015002.

# Some Challenges facing JJs

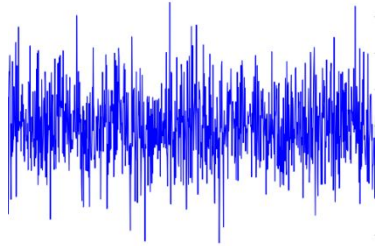
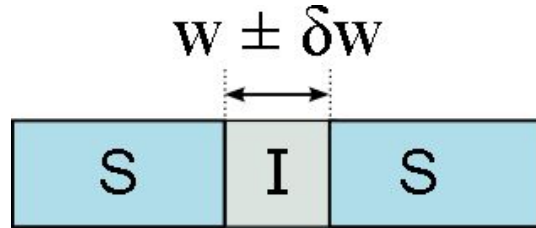

Tunnel  
barriers...

Magnetic noise

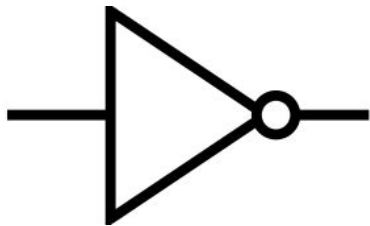

Selected applications (e.g.  
high-Z loads, fanout)

# The cryotron: magnetic suppression

- 1956, Dudley Buck at MIT
- Gate induces magnetic field
  - Suppresses channel  $I_c$

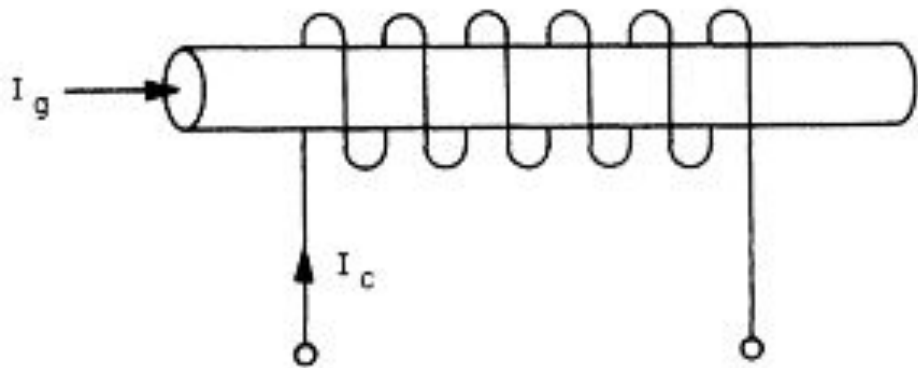

Buck, D. (1956). The Cryotron - A Superconductive Computer Component. Proceedings of the IRE, 44(4), 482–493. doi:10.1109/JRPROC.1956.274

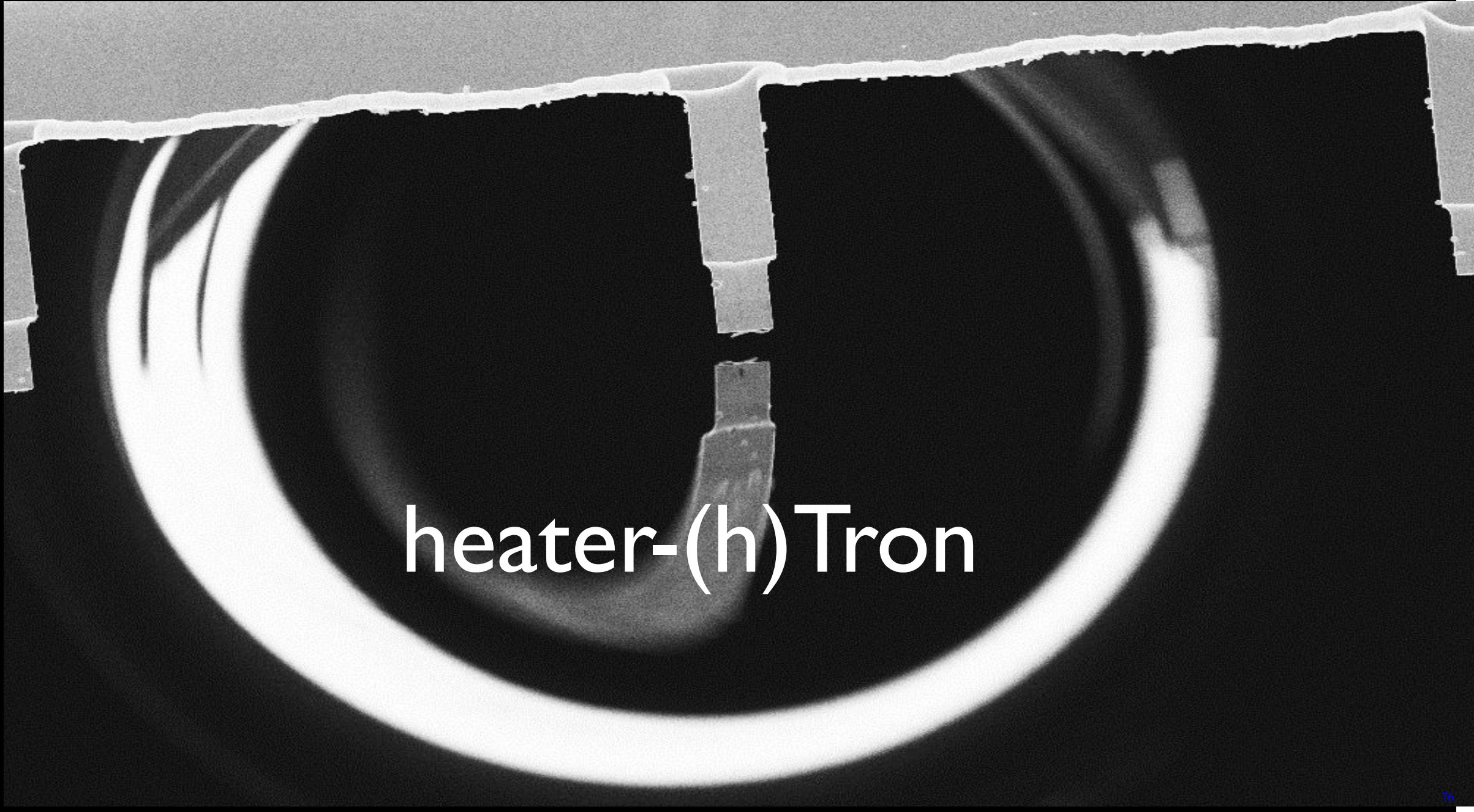

# heater-(h)Tron

# Thermo-Electric Switch

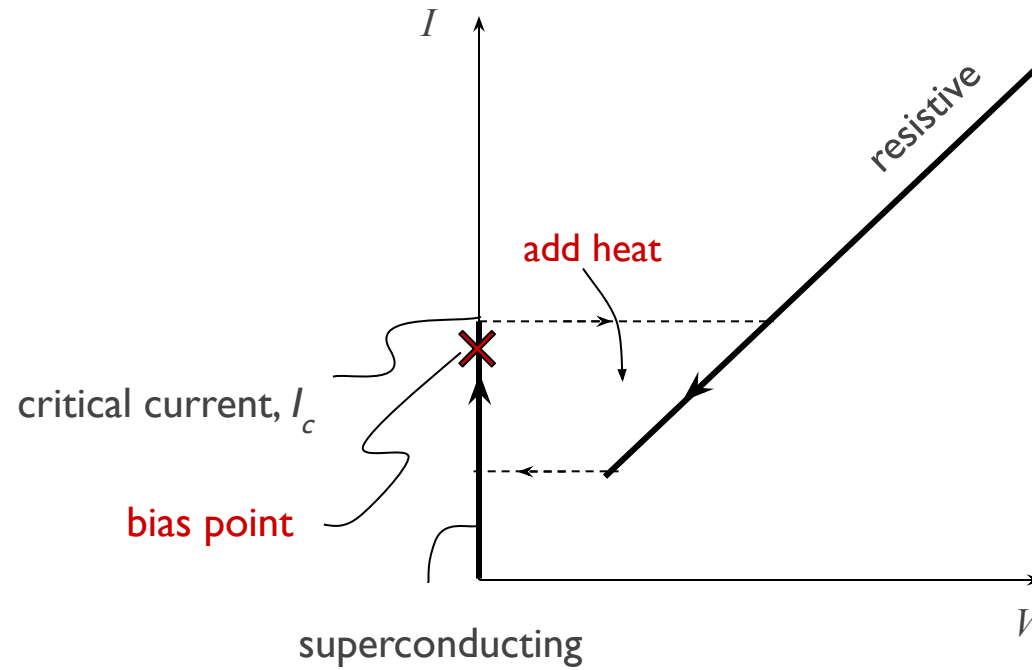

# Thermal Cryotron: heater (h)Tron

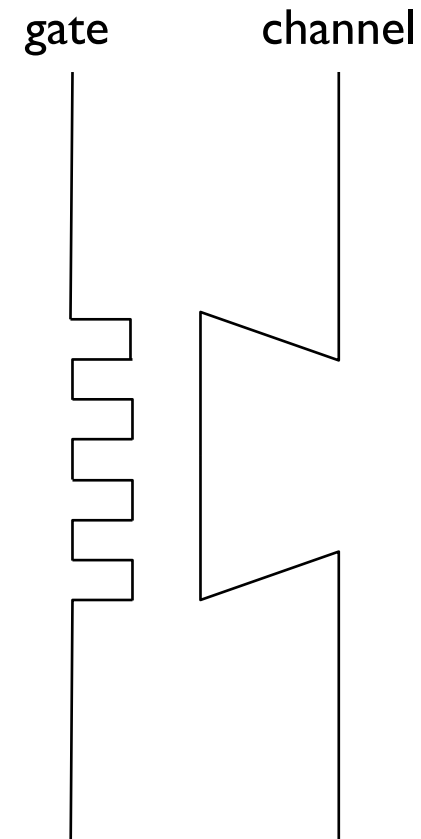
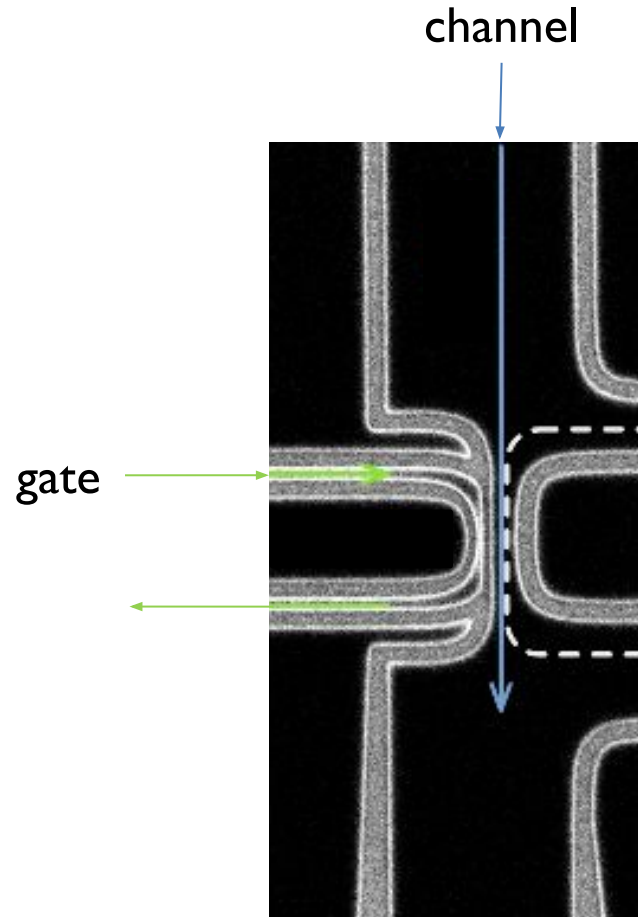

# hTron Switching Characteristics

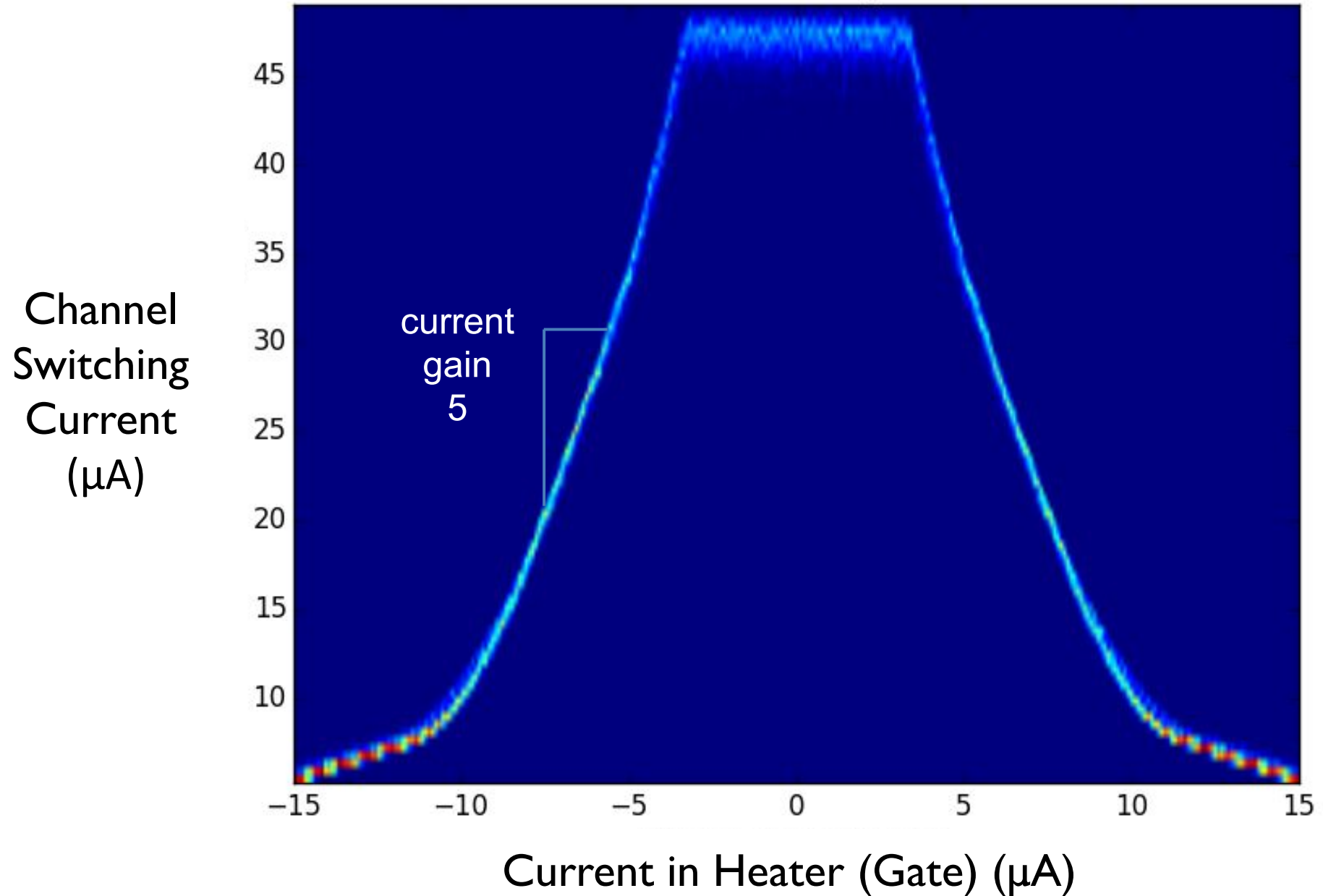

# nano-cryoTron

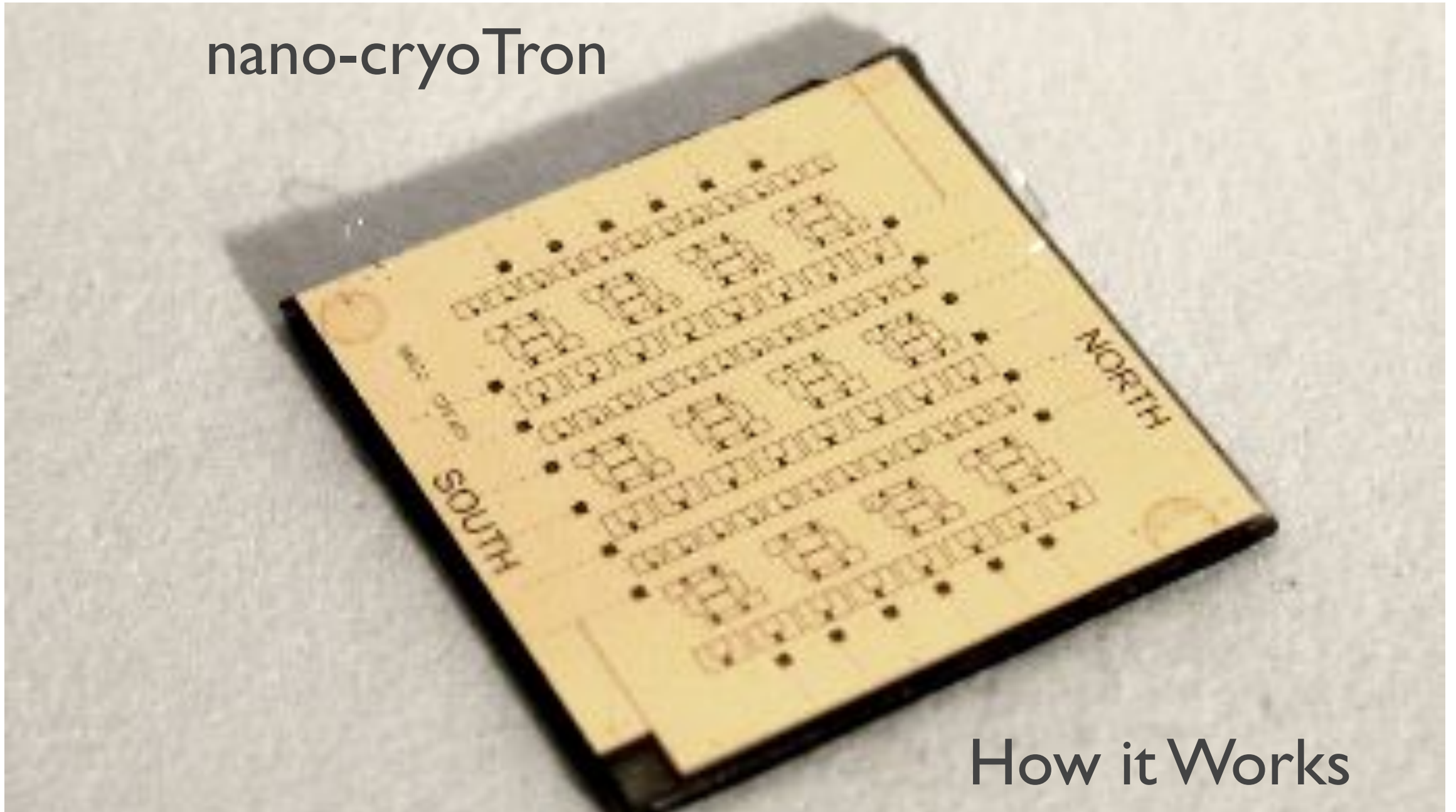

How it Works



# The nTron: Electrothermal suppression

- Suppression mechanism
  - Cryotron: Magnetic
  - nTron: Electrothermal
- Energy diffusion from hotspot
  - $L_D \approx 100$  nm for NbN
- Hotspot highly resistive, but speed limited by cooling

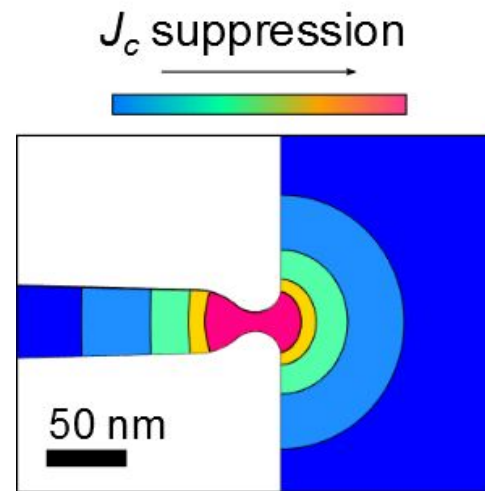
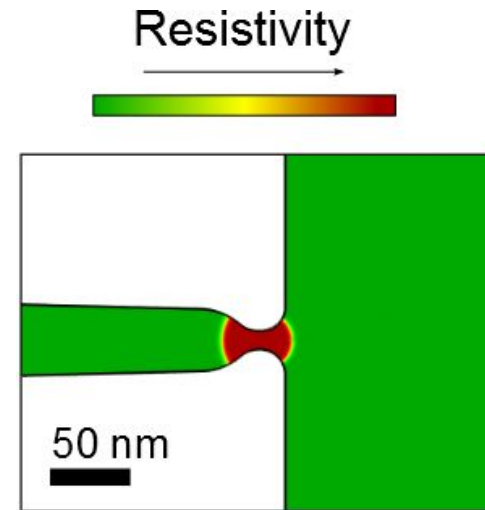

# nTron geometry

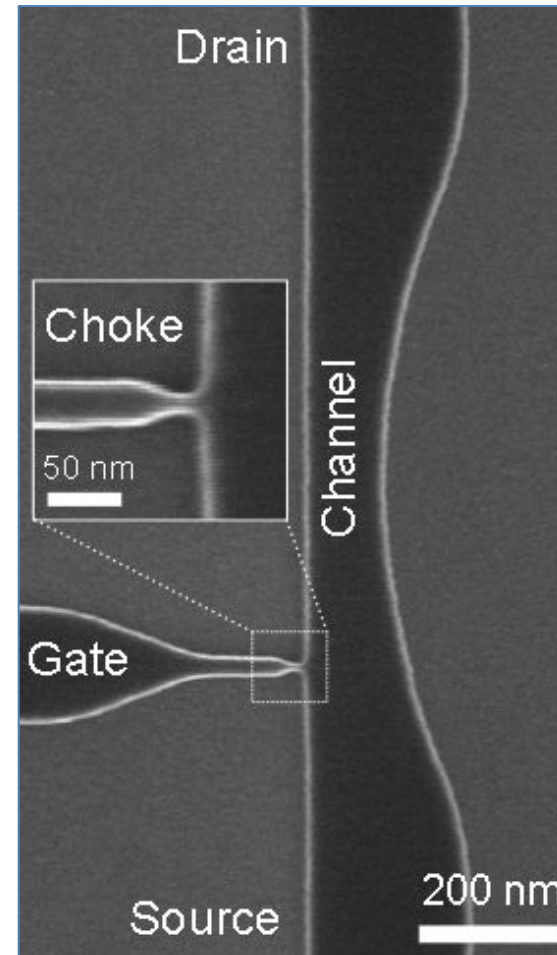
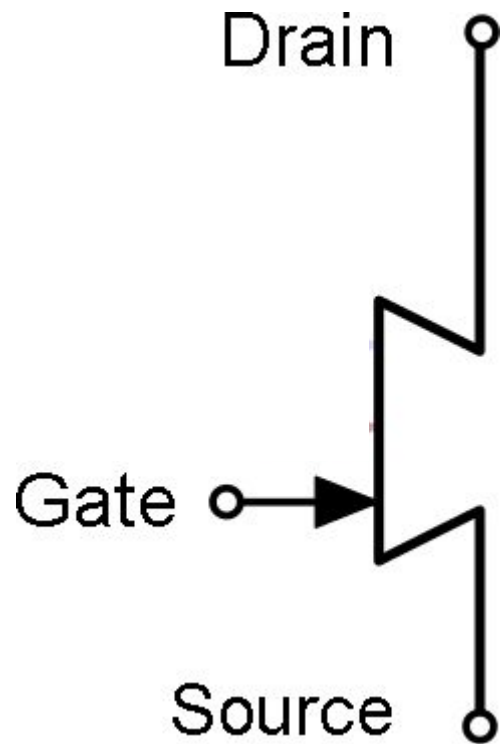

# Using the Nano-cryoTron

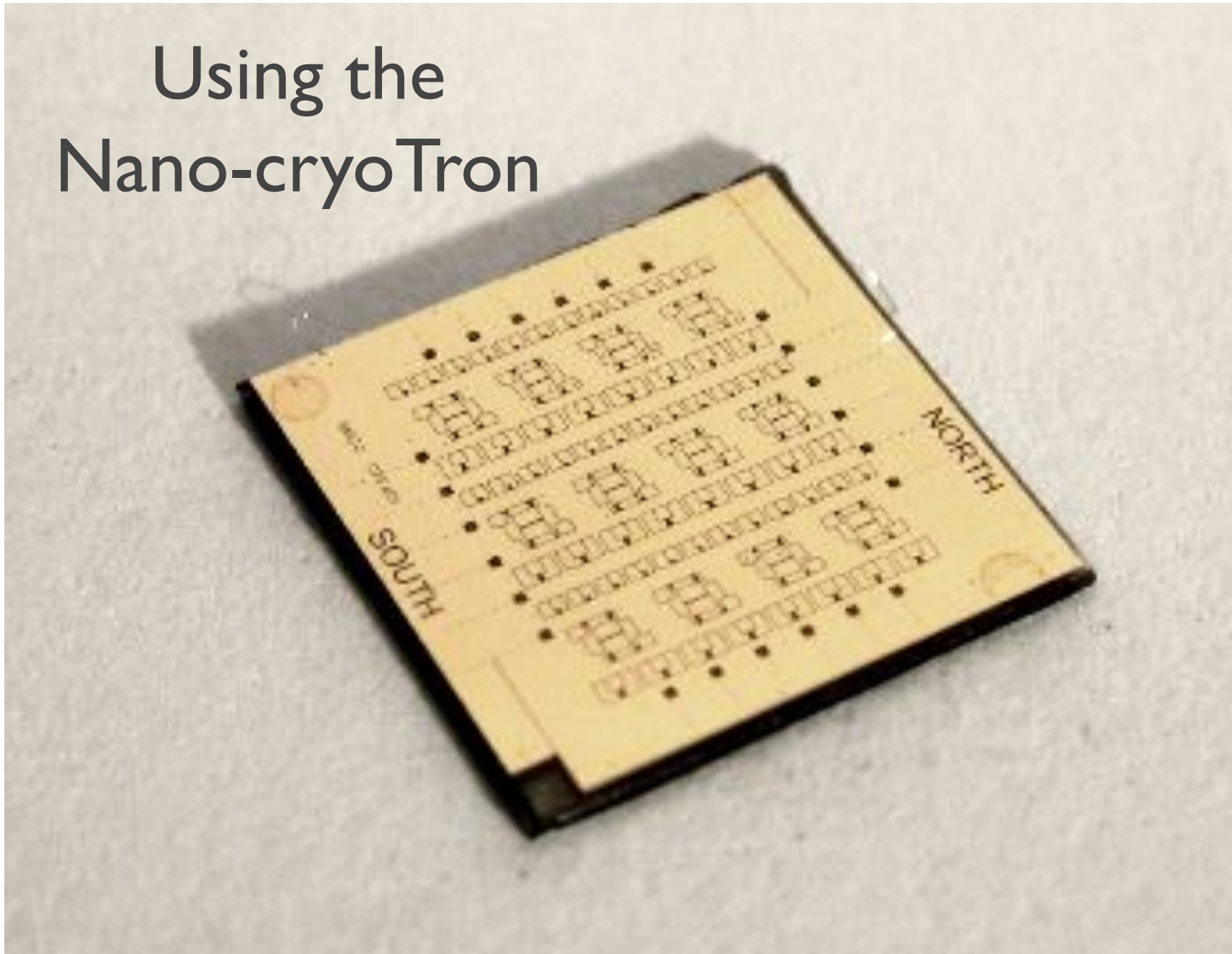

# Interface between RSFQ and Semiconductors

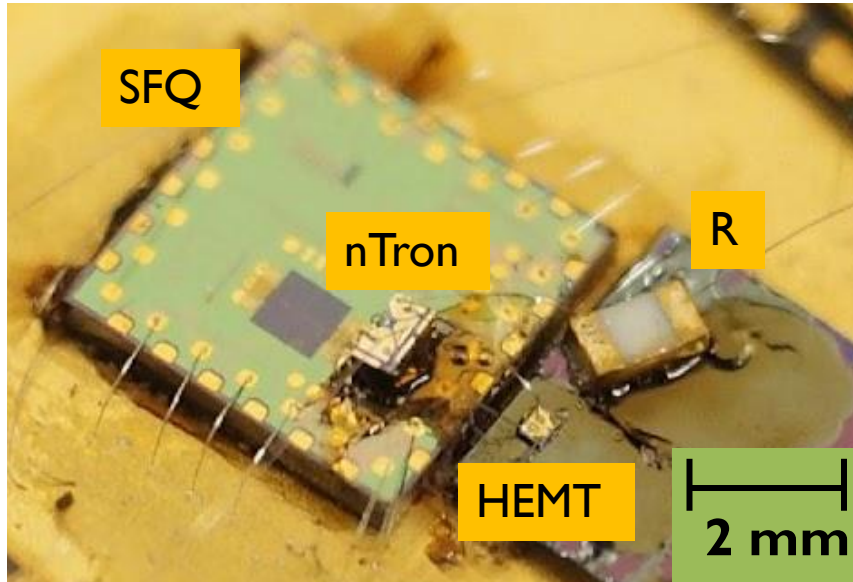

## Experimental demonstration

**SFQ  $\square$  nTron  $\square$  HEMT**

**Josephson junction  $\square$  nanowire  $\square$  transistor**

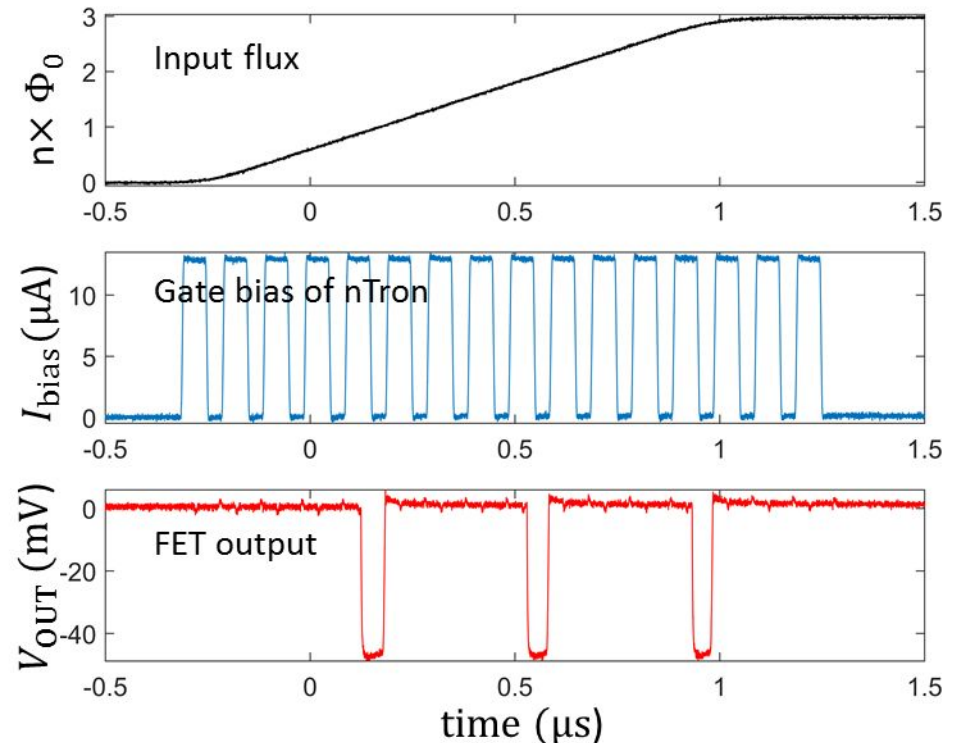
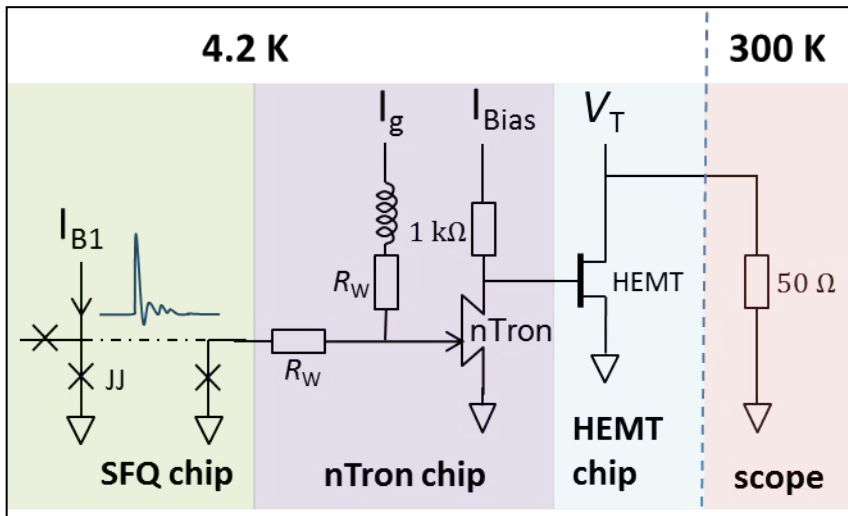

Collaborate with Thomas Ortlepp from CiS Research Institute for Microsensor Systems GmbH

# Half-adder results

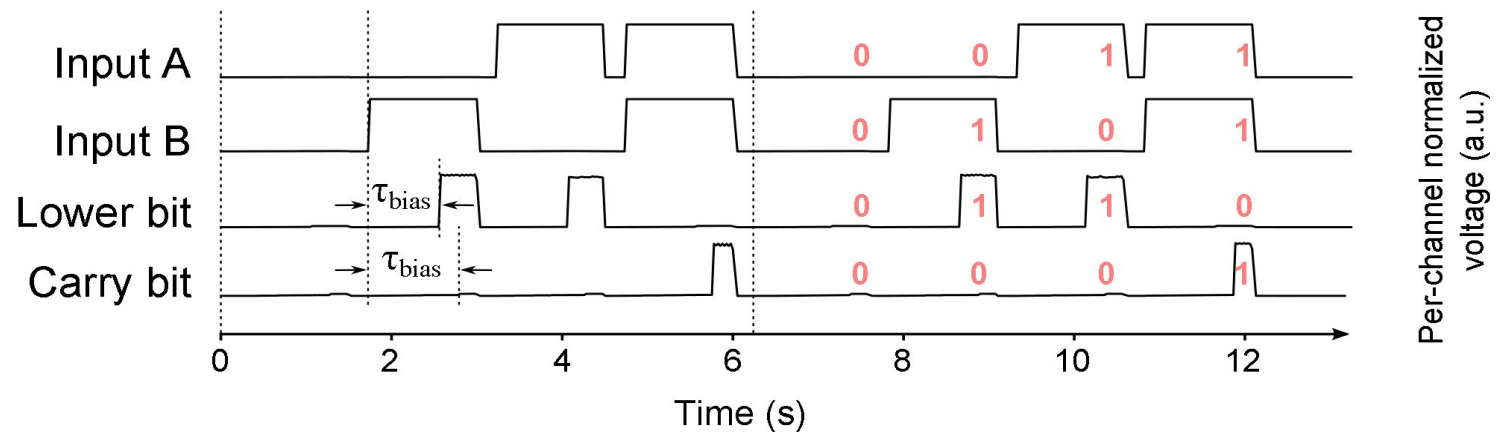
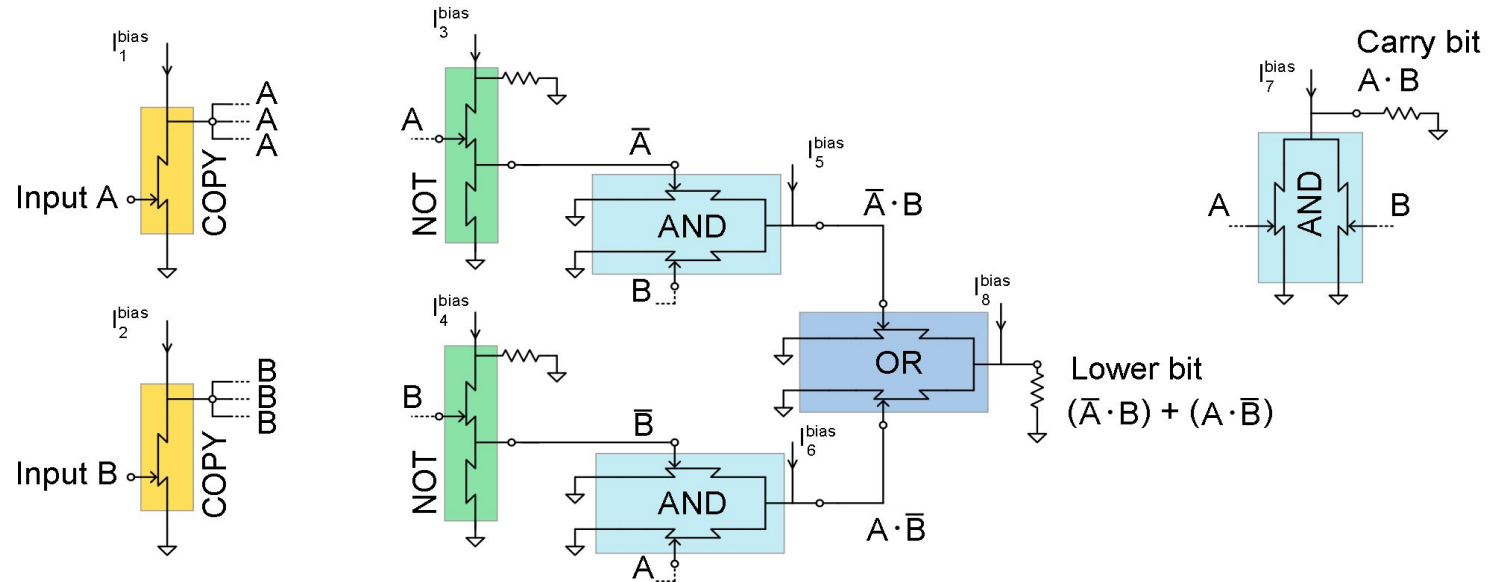
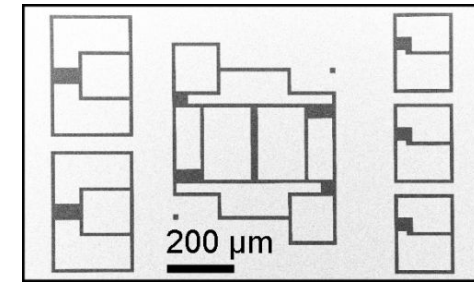
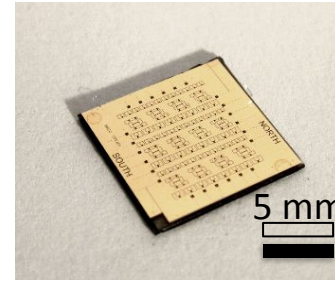

# Nanowire neuron: circuit

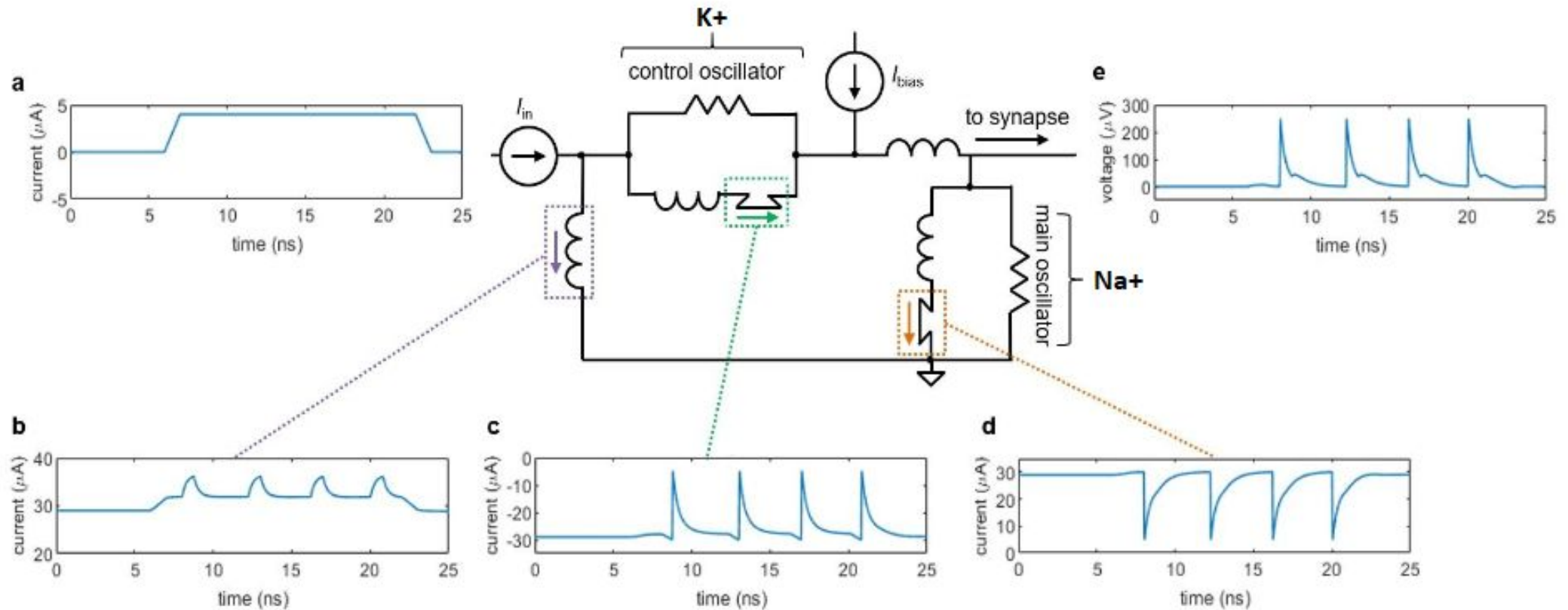

- Two nanowire relaxation oscillators act analogously to the two ion channels of a biological neuron
- Able to replicate biorealistic characteristics (e.g. refractory period, threshold response)
- Can use nanowire slow-wave transmission line as an axon  $\rightarrow$  preserve time-domain information

# Superconducting Nanowire Neuron

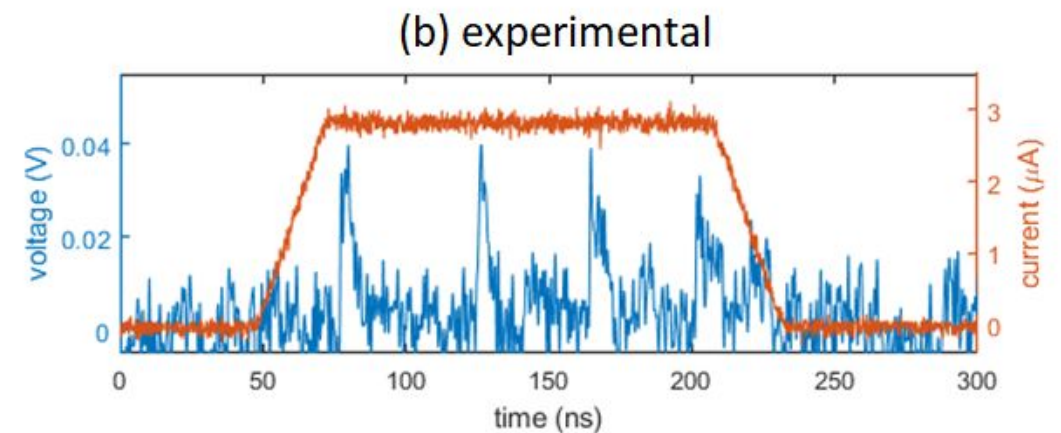
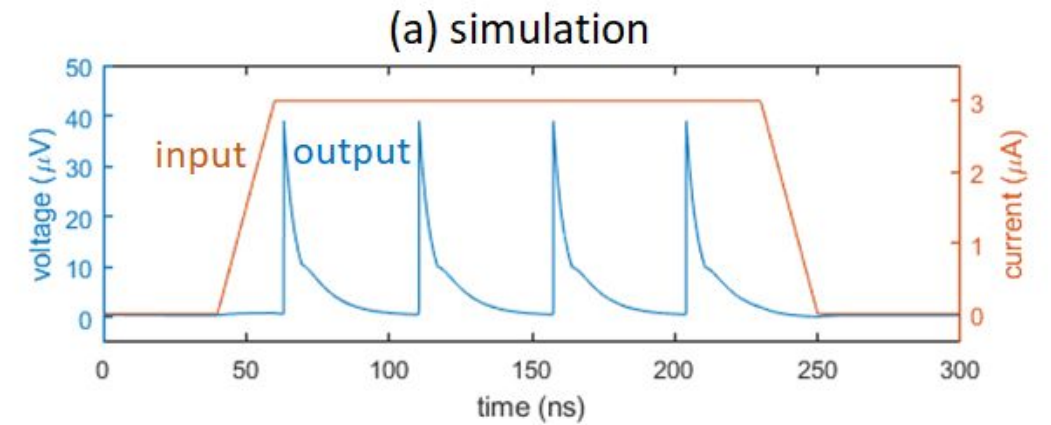
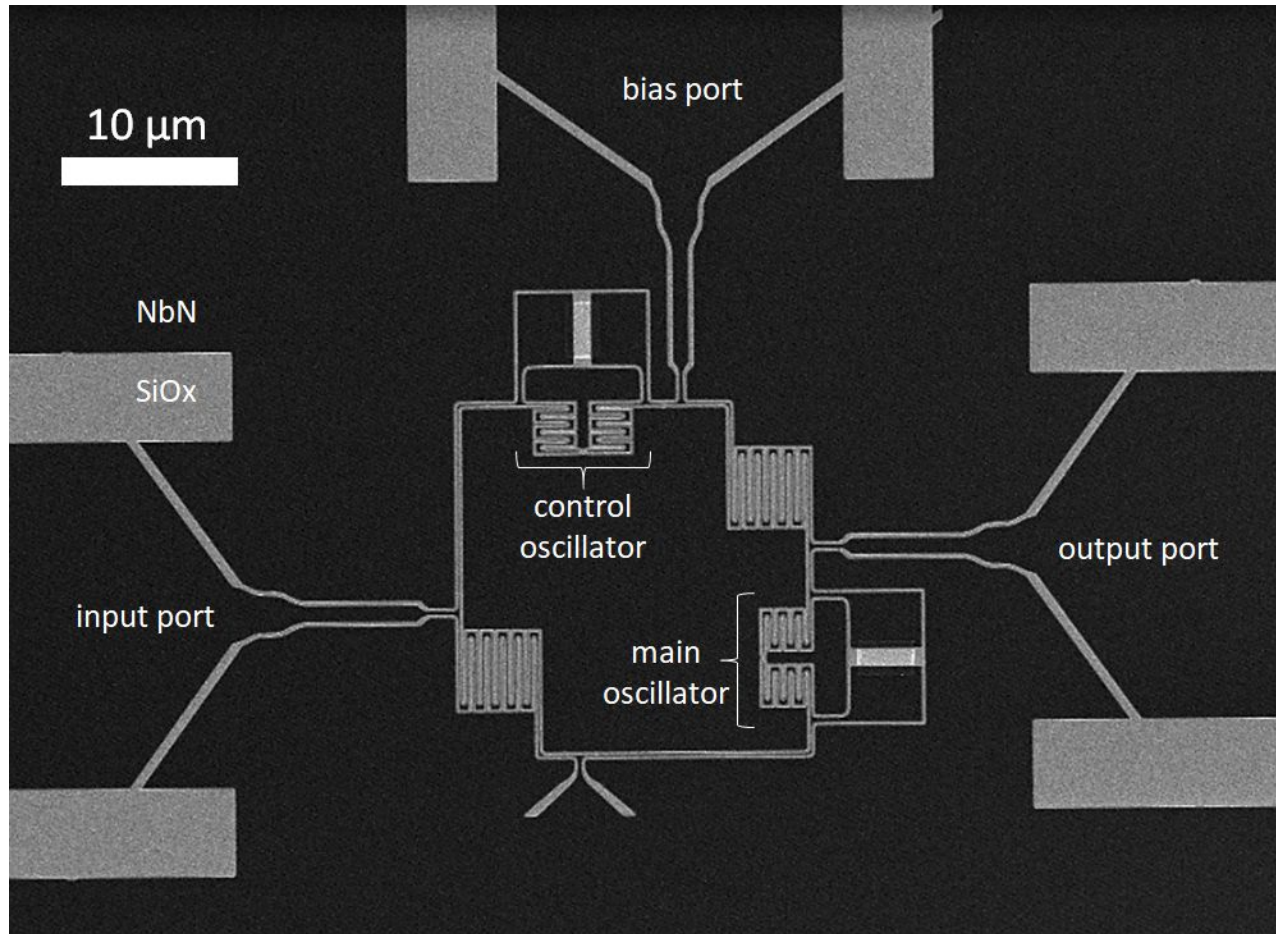

Emily Toomey, Ken Segall, Matteo Castellani, Marco Colangelo, Nancy Lynch, Karl K. Berggren  
“Superconducting Nanowire Spiking Element for Neural Networks” Nano Letters 20.11 (2020)

# “Pro”s and “Con”s of Nanowire-Based Electronics

## • “Pro”s

- Can drive high-impedance loads
- Fast turn-on ( $\sim 100$  ps) and excellent jitter ( $\sim 3$  ps)
- Low power consumption (tradeoff with output impedance)
- Simple materials and process

## • “Con”s

- Reset is slow ( $\sim$  ns)
- Electron-beam lithography is beneficial (maybe not required?)

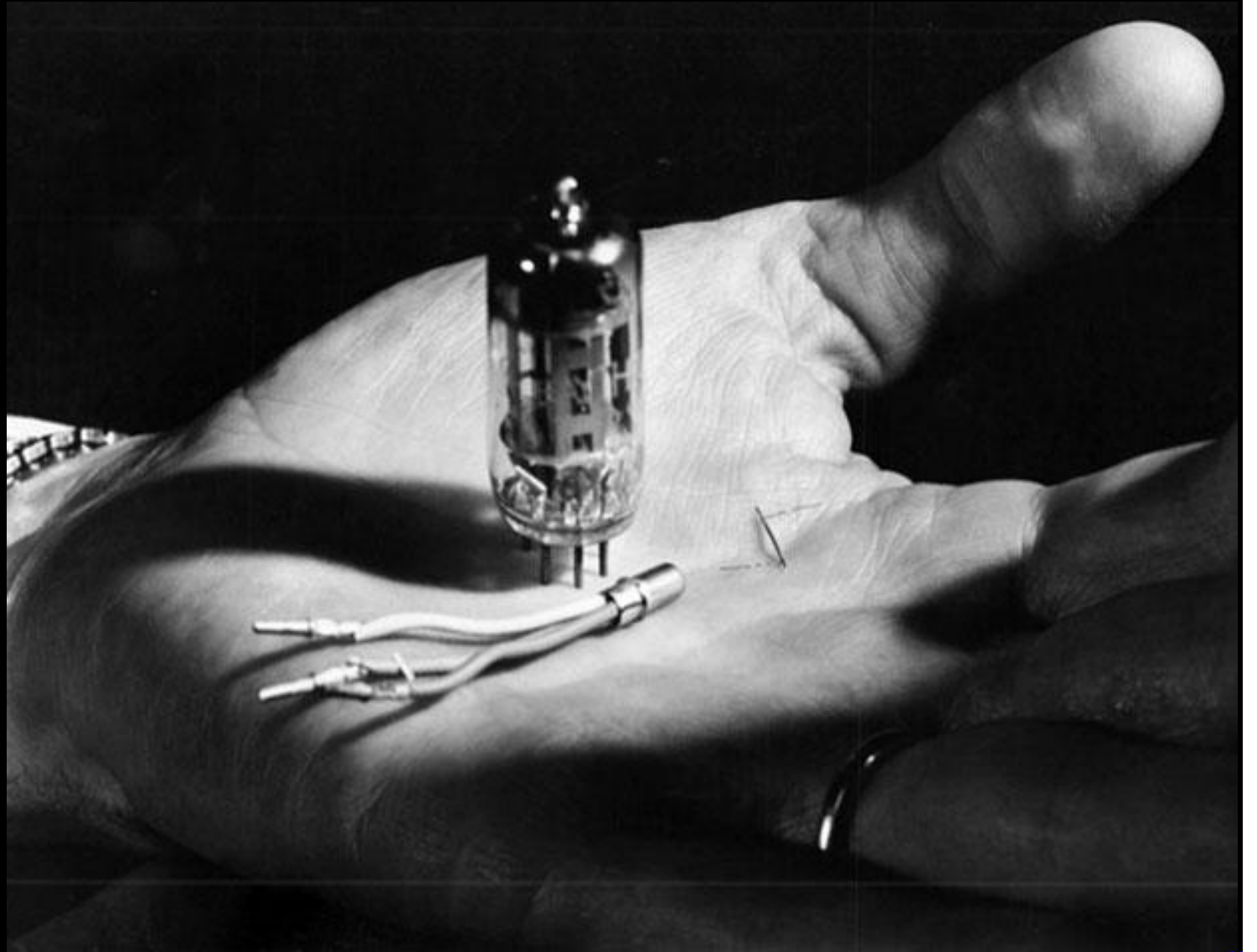



# Thank You!

- **To the hundreds (thousands?) of PIs, post-docs, students, technicians who have supported this field over decades, and the thousands of administrators/facilities workers/family members who have supported them.**
- **The major institutions that have been involved in this field include (in random order).**
  - **U. of Rochester, Moscow State Pedagogical University, Delft University of Technology, Karlsruhe Institute of Technology, National Institute of Standards and Technology, Yale University, University of Waterloo, University of British Columbia, Caltech Jet Propulsion Laboratory, EPFL Lausanne, MIT Lincoln Laboratory, Michigan State University, National Institute of Information and Communications Technology (NICT) in Kobe Japan, Nanjing University, Shanghai Institute of Microsystem and Information Technology (SIMIT), Heriot Watt University, Glasgow University, University of Roma TRE, Italian National Research Council (Rome, Naples)\*, KTH Royal Institute of Technology, Los Alamos National Lab, Chalmers University, EPFL, Eindhoven University of Technology, The Technion, and others that have slipped my mind...**

**Apologies in advance to anyone I neglected to mention.**

**berggren@mit.edu**

# Superconductivity Team in QNN Group



Emma Batson  
(Grad Student)



Brenden Butters  
(Grad Student)



Ilya Charaev  
(Post-Doc)



Marco Colangelo  
(Grad Student)



Glenn Martinez  
(Masters Student,  
BU)



Owen  
Medeiros  
(Grad Student)



Dip Joti Paul  
(Grad Student)

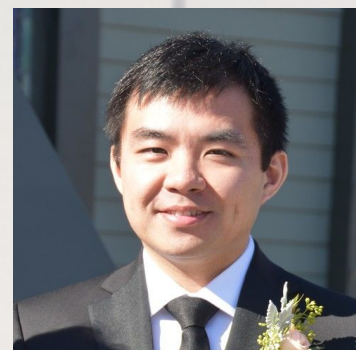

Tony Zhao  
(Post-Doc)

## Graduated/Former

Nathan Abebe  
Lucy Archer  
Reza Baghdadi  
Francesco Bellei  
Andrew Dane  
Ignacio Estay Forno  
Niccolo Calandri  
Yachin Ivry  
Adam McCaughan  
Faraz Najafi  
Murat Onen  
Ashley Qu  
Kristen Sunter  
Emily Toomey  
Hao-Zhu Wang  
Qing-Yuan Zhao  
Di Zhu

Andres Lombo (U. of Toronto, Undergraduate) Jesus Lares (MIT, Undergraduate)

Thank you to Lara Ranieri and Rinske Wijtmans for assistance in preparing these slides for presentation

# Collaborators



Boris Korzh  
(JPL)

- Emma Wollman (JPL)
- Angle Velasco (JPL)
- Andrew Beyer (JPL)
- Jason Allmaras (JPL)
- Edward Ramirez (JPL)

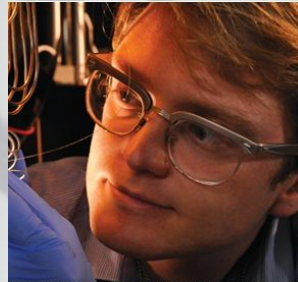

Matthew Shaw  
(JPL)



Daniel Santavicca  
(UNF)

- Brian Noble (UNF)
- William Strickland (UNF)



Ken Segall  
(Colgate)

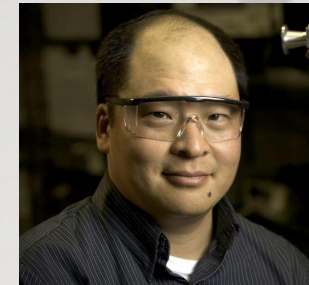

Sae Woo Nam



- Varun Verma (NIST)
- Jeff Chiles (NIST)
- Adriana Lita (NIST)



Joshua Bienfang  
(NIST)

# MIT's Graduate Engineering-Physics Program within Dept. of EECS

- <https://gradapply.mit.edu/eecs>
- Deadline December 15th

## My Group

- <https://www.rle.mit.edu/qnn>
- [berggren@mit.edu](mailto:berggren@mit.edu)

To see related videos, please visit our website,  
or look for us on YouTube

# SUPPORT

- Dept. of Energy
- U.S. Air force Office of Scientific Research
- U.S. Office of Naval Research
- DARPA
- IARPA
- NASA
- NSF
- Many U.S. and international fellowships including NSERC

A micrograph of a superconducting circuit, likely a Josephson junction array or a similar quantum device. The image shows a central rectangular region with a light beige background, surrounded by a complex network of dark, metallic lines. These lines form a series of parallel, slightly curved paths that converge towards the center, creating a fan-like or comb-like structure. The lines are interconnected, forming a grid-like pattern. The overall appearance is that of a highly precise, micro-fabricated device.

**END OF  
PRESENTATION**