



1-LO-PT.4 ***Implementation of a 2400-meter long HTS cable line project in the power system of St. Petersburg.***

Victor Sytnikov  
LLC "CryoPowerSystems"  
ROSSETI R&D Center

EUCAS 2025  
22.09.2025. Porto

## CONTENT

*Background*

*HTS DC Cable Line in St. Petersburg*

*Cable and cable fittings*

*Electrical diagram*

*Cryogenics*

*Tests in Moscow*

*Installation of the line in St. Petersburg*

*Acceptance tests*

The benefits of employing HTS materials are most evident in the context of direct current applications. HTS cable benefits.

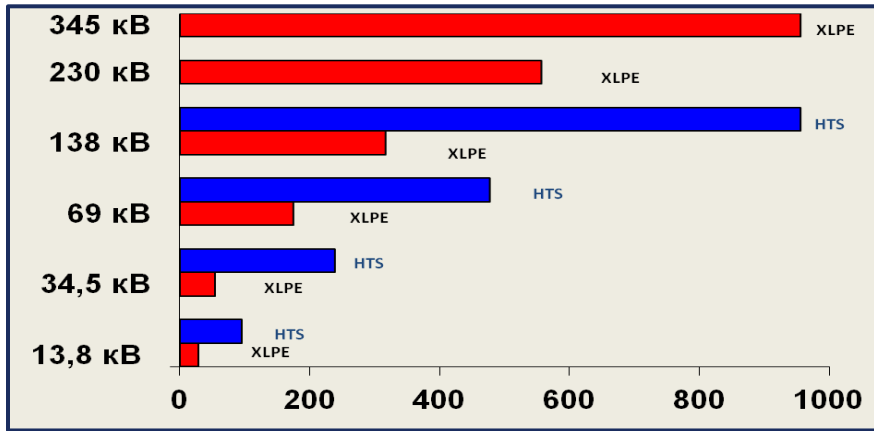

Energy transmission can be carried out on direct current and alternating current, however, there is little energy loss on alternating current and there is a limit on the maximum transmission length.

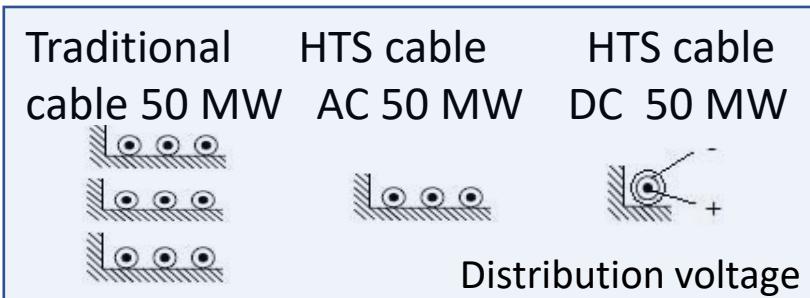

- 1 Loss reduction at electric power transmission
- 2 High power transmission at medium voltage
- 3 Cable line area reduction
- 4 Enhancement of electrical grid controllability
- 5 Limitation of short-circuit current
- 6 Mutual redundancy of grid sections
- 7 Environmental friendliness and fire safety

## Main purposes of the project:

- ❖ Making HTS DC link - 20kV, 50 MW for St. Petersburg network.
- ❖ Creation of scientific – production cooperation for manufacturing HTS cables, fittings, converters and cryogenic equipment
- ❖ Creation and demonstration replicated HTS DC link.
- ❖ During line operation to receive new experience and define real operating cost.

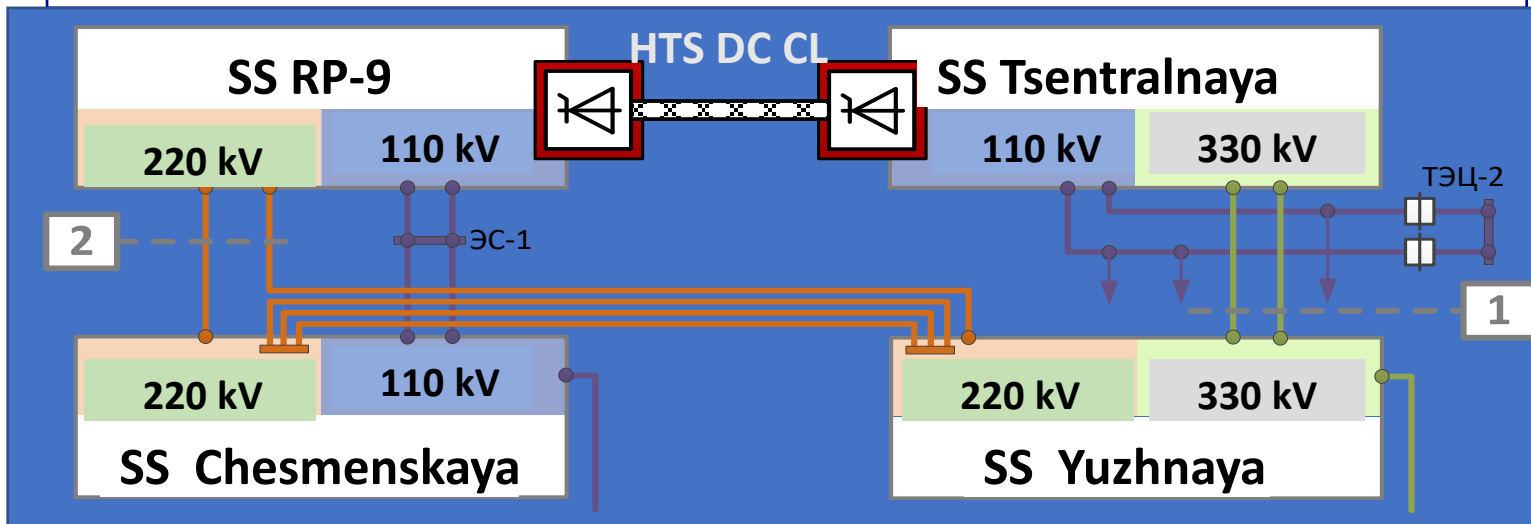

HTS DC line connects the RP-9 and Tsentralnaya substations, in normal mode, offloads adjacent lines and reduces energy losses in the network. In emergency or repair mode, it allows to maintain a stable energy supply to consumers.

## Specification

Transmission power	50 MW
Operating voltage	20 kV
Operating current	2500 A
Operating temperature	66-80K
Length	About 2400 meters
Converters type	Twelve pulsed
Transmission reverse mode	Exists
Cooling capacity	12 kW @ 70K
Pressure LN	up to 1.4MPa
Mass flow rate of LN	0.1 ÷ 0.6 kg / s

## DC line include:

- HTS cable and reverse cryostat
- Terminals and connecting couplings
- Cryogenic system
- Two converter substations
- Monitoring and control systems.

## Development and construction of HTS DC cable line

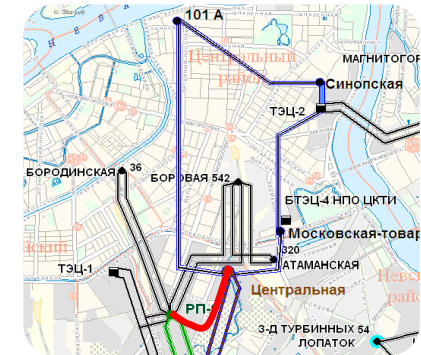
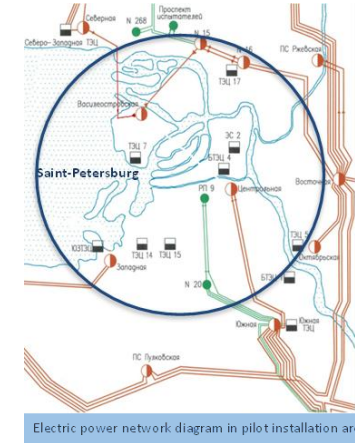
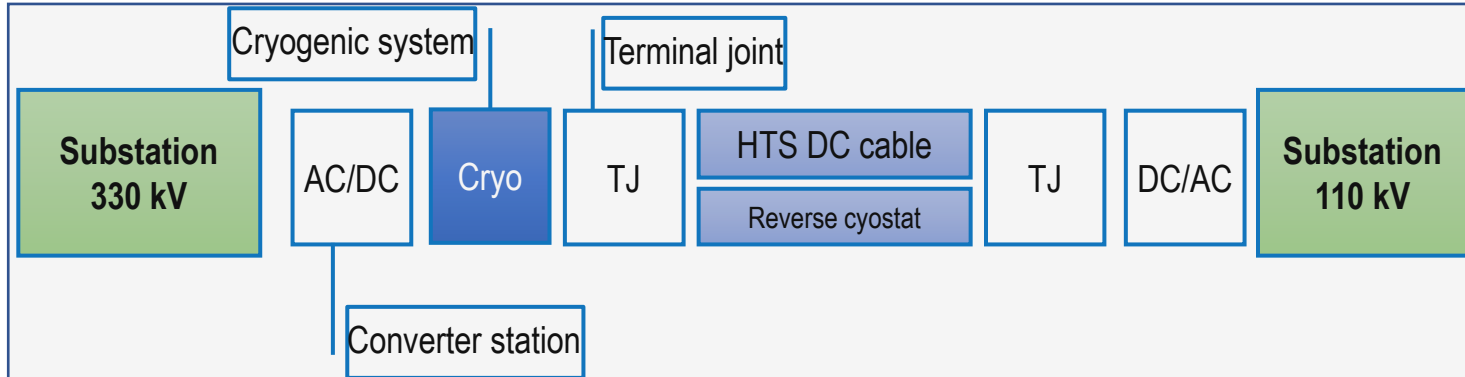

The line will connect two deep-laid electrical substations, thereby enhancing the power supply reliability for the Central and Admiralteysky districts, home to approximately 400 thousand people.

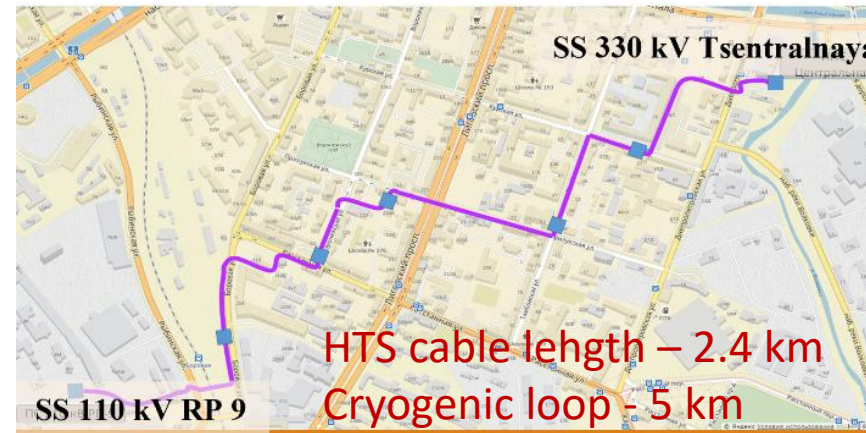

**Today, this HTS line is the longest in the world.**

## Superconducting Cable Design

### Unipolar Cable with Forward and Reverse Conductors

- Former and stabilizing element;
- superconducting direct conductor (22 SEI tapes with  $I_c=160A$ );
- high-voltage insulation;
- superconducting reverse conductor (19 SEI tapes with  $I_c=180A$ );
- external Cu stabilizer;
- external (screen) insulation;
- Nexans cryostat;
- protective coating.



Development of the HTS cabling technology was performed on “Irkutskcable” plant

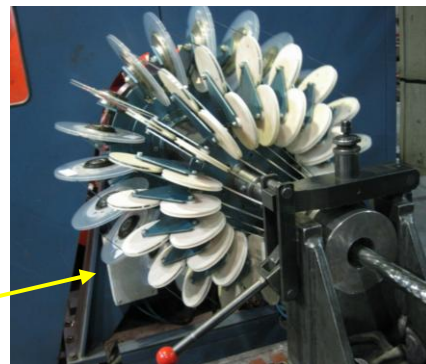
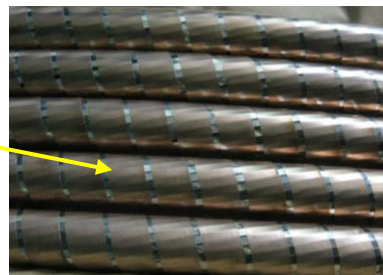

## Current leads



Material	Brass rod
Length	0.45 meter
Diameter	48 mm
Heat input @ $I=0$ A	58.5 W

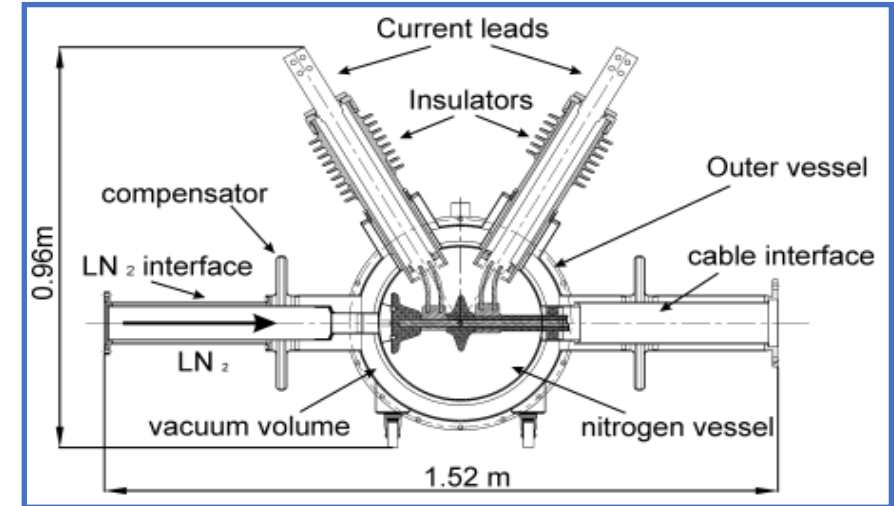

## Joints

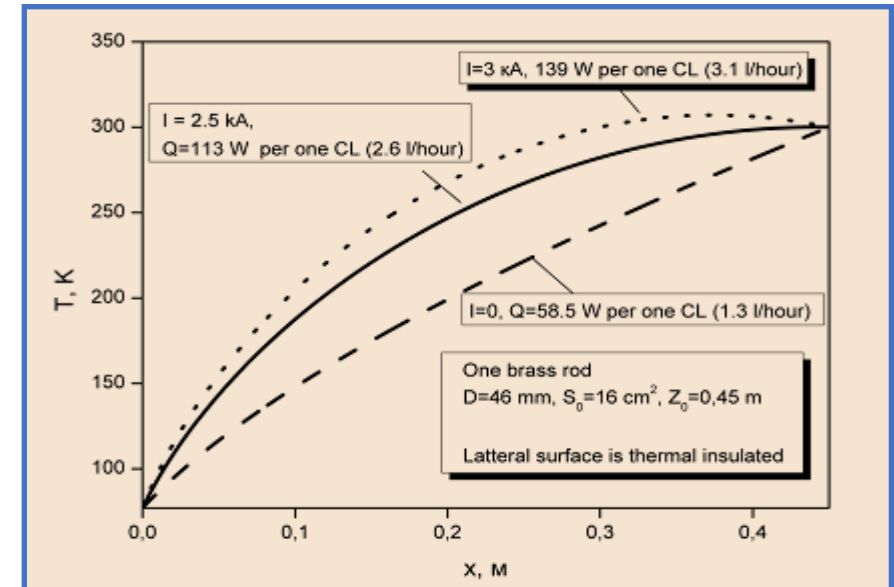
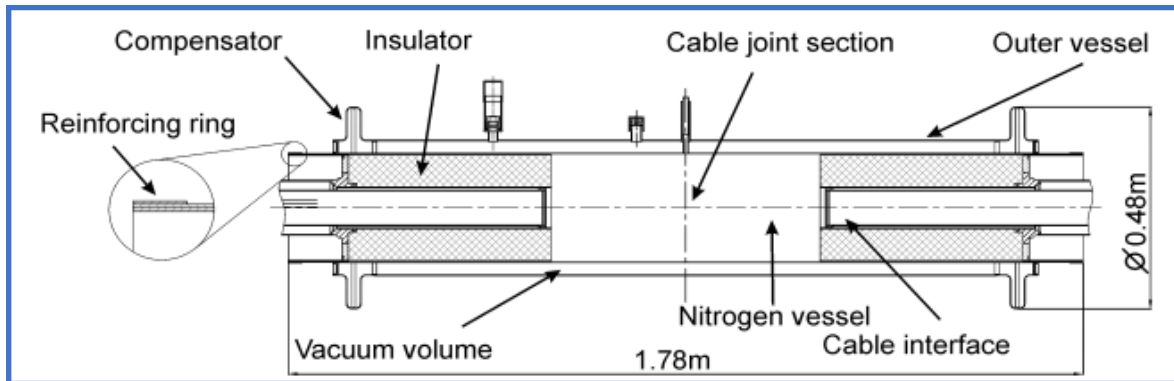

A. Naumov, et al., "Current leads and joints for HTS DC Cable of 2.5 kA 20 kV" *Adv. Cryog. Eng.* vol. 1573. p. 16922014.

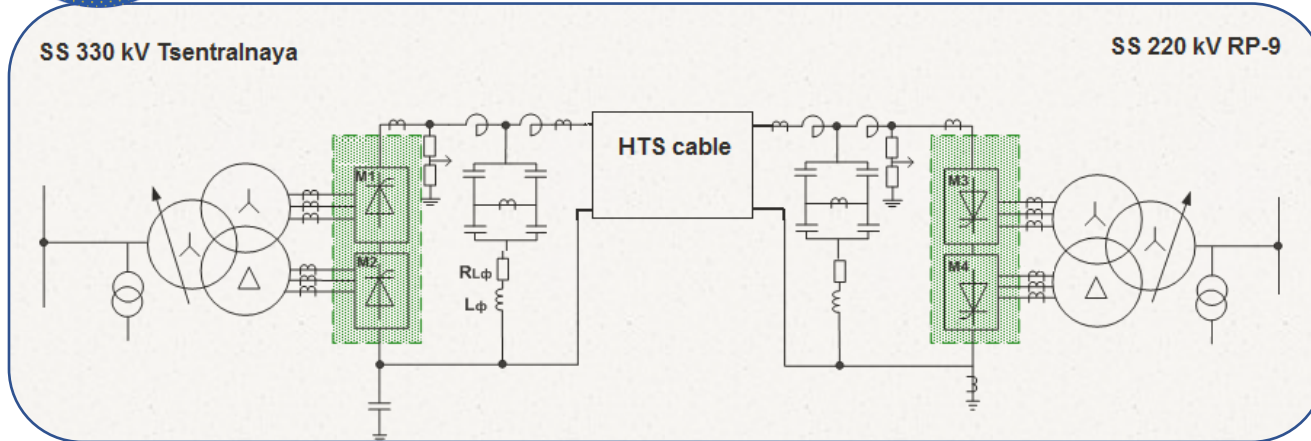

Specification of the rectifier – inverter circuit

Converter circuit	Twelve-pulsed
Matching transformer	65 MVA; 110/8.27/8.27 kV
DC voltage	20 kV
Rated current	2500 A
Rated power	50 MW
Reverse mode	present
Valve type	Thyristor
Filter setting	Twelfth harmonic

50MW AC-DC-AC substation



Control cabinet



Control module



L – C filter



## Cryogenic loop – 5 km

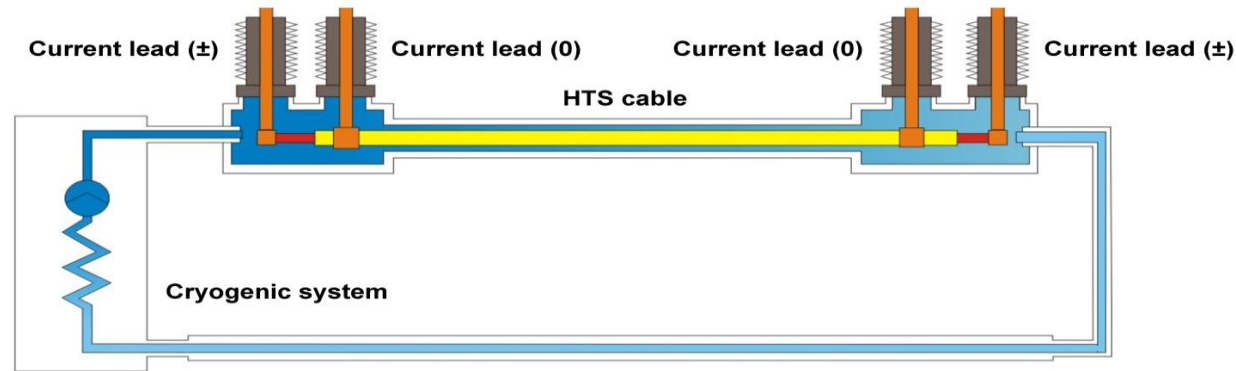

## Cryogenic System

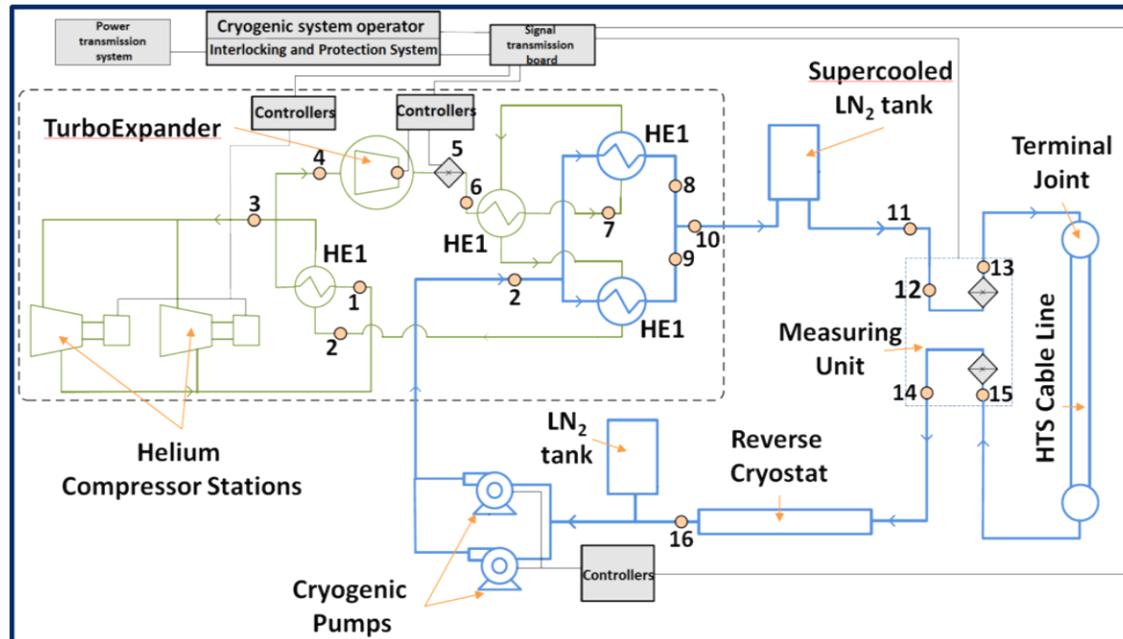

## Cryogenic system on the SS “Tsentralnaya”

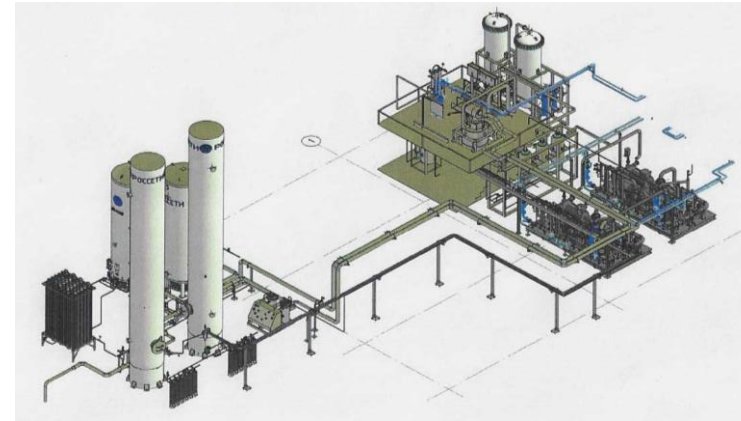

### The nitrogen circuit includes the following.

- ✓ Liquid nitrogen pumping unit includes two cryogenic pumps (one in operation, the second one is a backup).
- ✓ Two heat exchanger “gaseous helium – liquid nitrogen.”
- ✓ Supercooled nitrogen tank.
- ✓ Liquid nitrogen filling tank.
- ✓ HTS cable double-wall cryostat.
- ✓ Reverse cryostat.

### The helium circuit includes the following.

- ✓ Two modular helium compressor stations (one in operation, the second one is a backup).
- ✓ Valves for automatic switching between helium compressors in case of failure of the main compressor station.
- ✓ Helium turboexpander.
- ✓ Heat exchanger “gaseous helium - liquid nitrogen.”

## Tested in Moscow

- In the "Kurchatov Institute" 2x30 meters at 80K
- In "Rossety R&D Center" 2x30 meters at 68K – 78K
- -- 2x430 meters at 78K
- -- 2400-meter cable line with 2+5 couplings

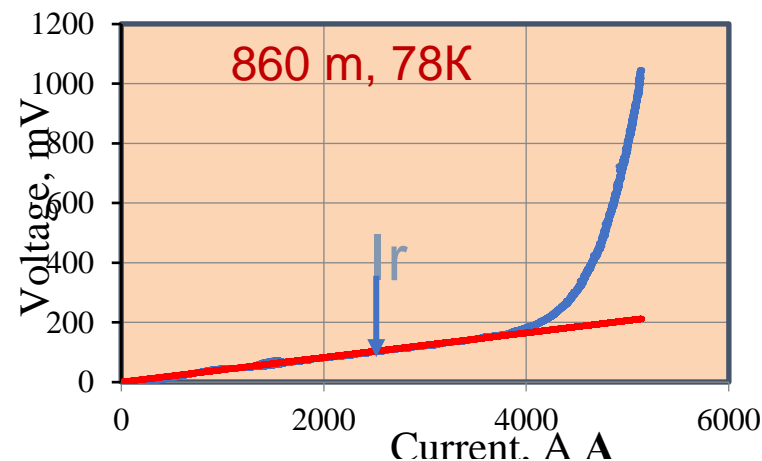
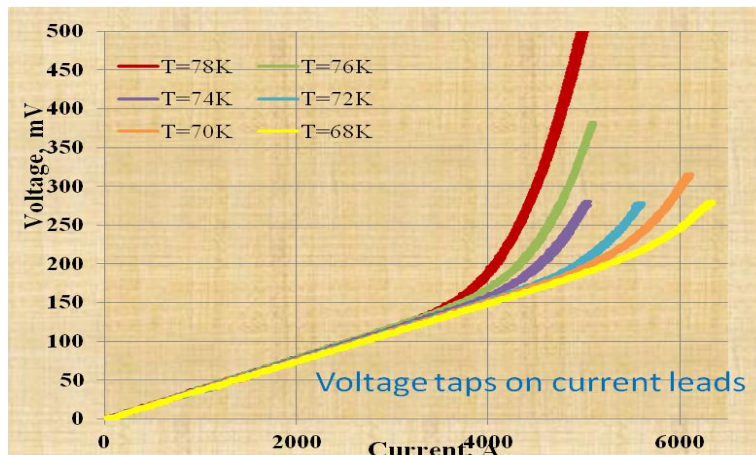
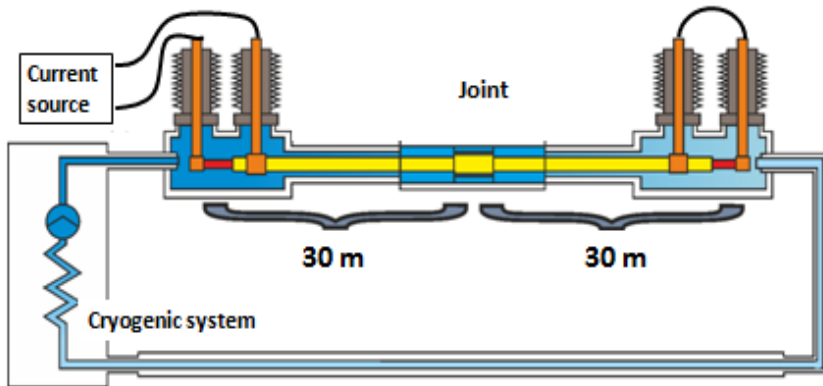

## HTS DC cable test program

Test items	Subject	T, K		Result
		300	78	
Visual inspection	All	x		ok
Vacuum tightness	Flow tract	x		ok
	Cryostat	x	x	ok
	Current lead box	x	x	ok
High pressure test	Cable in cryostat	x		ok
	Current leads box	x		ok
High voltage test	Current lead	x	x	ok
	Main insulation		x	ok
	Screen insulation		x	ok
Resistance	Conductor	x		ok
	Current leads	x	x	ok
	Joint	x	x	ok
Bending test		x		ok
Current distribution test	Direct conductor		x	ok
Critical current test	Direct conductor		x	ok
	Reverse conductor		x	ok
Overload test			x	ok
Short circuit test			x	ok
Pressure drop measurement			x	ok
Thermal cycle		x	x	ok
				11

## Voltage-current characteristics of forward and reverse conductors with a length of 2400 meters

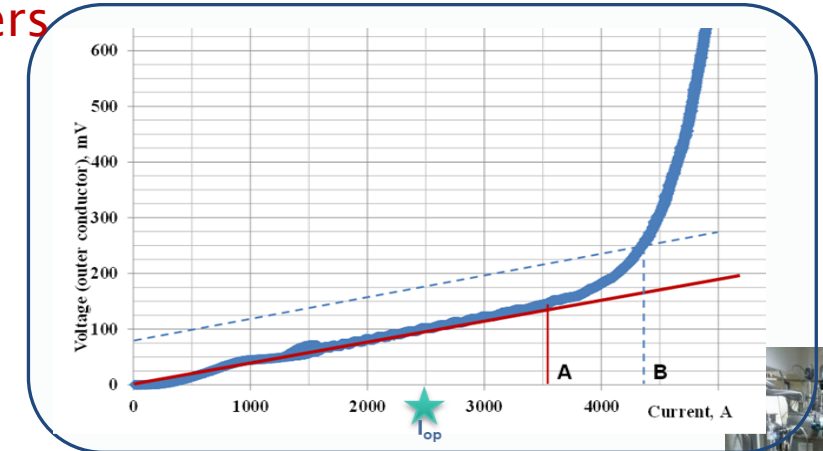
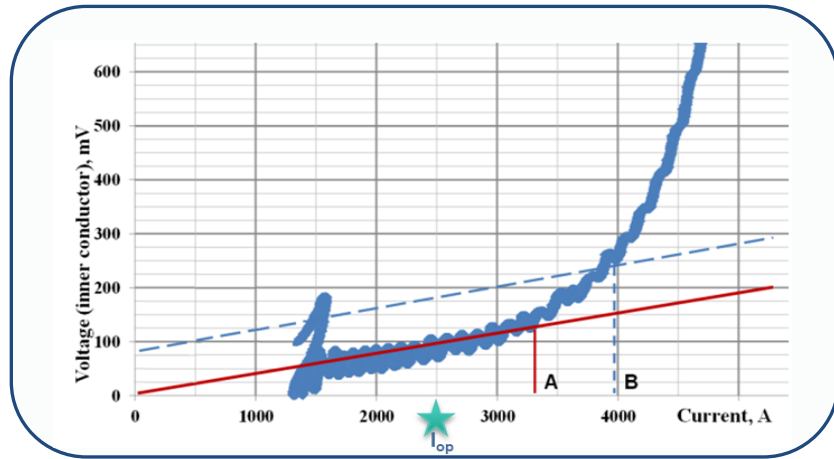

The pressure drop in the full length cryogenic loop as a function of flow rate

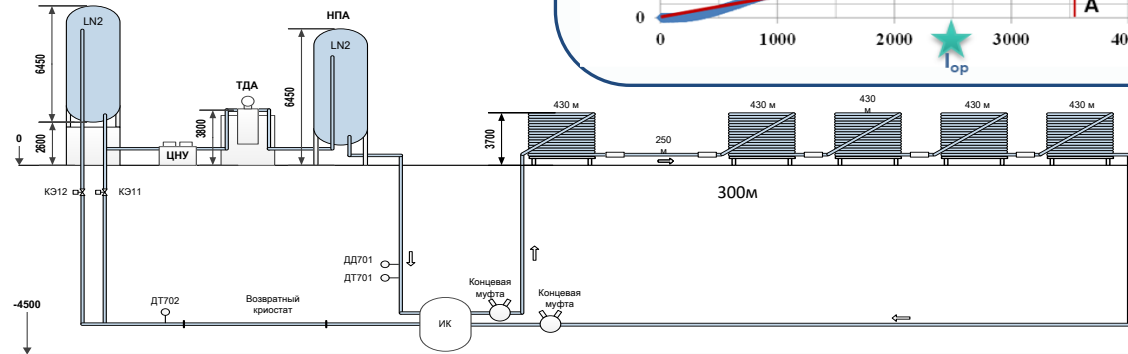
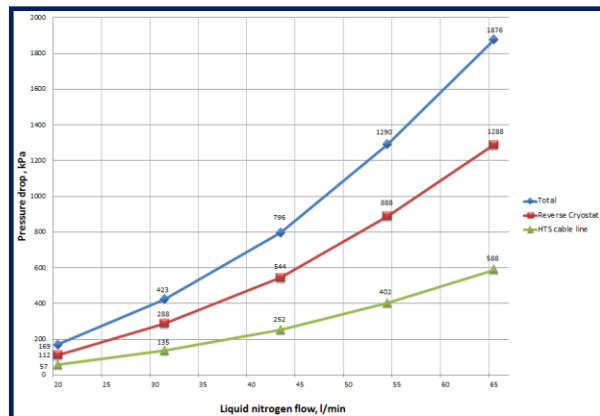

### Test Results

- The critical current of the cable is equal to the sum of the critical currents of the original HTS tapes.
- The resistance of the current leads and joints is stable up to 5000 amperes.
- All cable line parts were successfully tested with a high voltage of 50 kV, 30 minutes.
- The previously selected operating LN flow rate of 30-35 l/min provides acceptable operating parameters (temperature difference about 6.0 K and pressure drop 1.5-2.0 bar along the cable at total pressure drop about 4-5 bar).
- The temperature difference along the superconducting cable can be reduce to 3.0-3.5 K at 47 l/min flow rate.
- All calculated characteristics have been achieved or exceeded.

The cable line and technological equipment were dismantled, the HTS cables were rewound onto transport drums and taken to St. Petersburg.

## Laying of the cable route



The cable line route passes through residential and industrial areas of the city, crossing several busy highways and one railway line. There are 5 reinforced concrete cable manholes with connecting sleeves installed on the route.

Laying was carried out in a concrete tray in which the following elements were placed:

- HTS cable in a cryostat.
- Reverse cryostat without cable.
- 0.4 kV cable for power supply of equipment and signaling installed in cable manholes.
- Two fiber-optic communication lines for transmitting information between substations;
- Fiber-optic lines for diagnostics and temperature monitoring along the cable line route.

The cable was pulled from the middle connecting sleeve M-3 in the direction of the buildings of the SS "Tsentralnaya" and SS "RP-9", respectively.

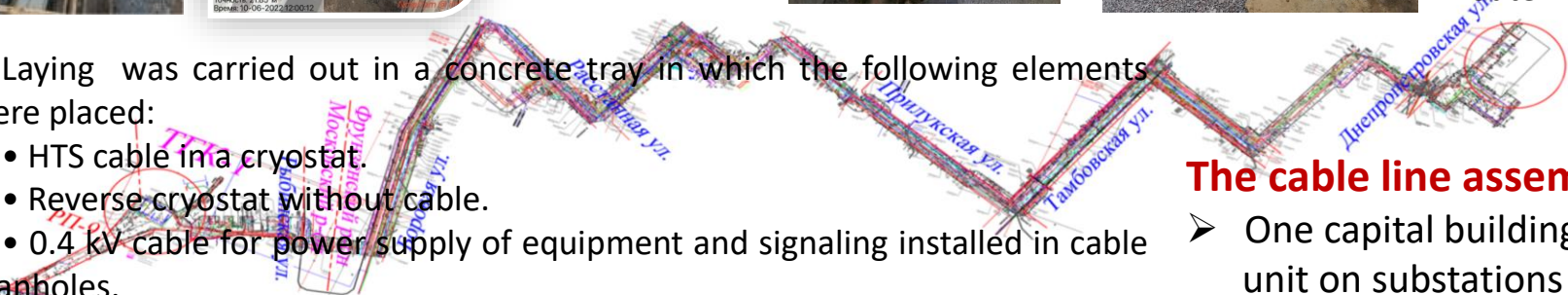

### The cable line assembly includes

- One capital building and one an integrated unit on substations RP-9.
- 2.4 km of HTS cable in cryostat.
- 2.5 km reverse cryostat.
- One 0.4 kV cable.
- Three fiber-optic lines.
- Five connecting couplings – cable manholes.
- Two cable terminations.
- Two converter AC-DC-AC substations.
- One cryogenic system.
- Monitoring and control systems.

At the intersections of the route with important highways, the cable was laid using the horizontal directional drilling (HDD) method. The total length of the four HDD sections is 437m.

The **cooling of the cable line** was carried out in two stages. At the first stage, gaseous nitrogen with a temperature of 90 K was used. At the second stage, the line was cooled by pumping supercooled LN with a feed temperature of 66 K. The total cooling time with liquid nitrogen was about 8 hours. The cable cooling process was controlled indirectly by measuring cable core electrical resistance.

Insulation resistance measurement in LN  
Main 2.11 GigaOhms, Screen 432 MegaOhms



## Nominal characteristics of the cryogenic supply system

Indicator name	Value
Cooling capacity at T=66K, kW	12
Mass flow rate of liquid nitrogen, kg/s, no more than	0,1 – 0,6
Nitrogen pressure at the input of the power cable, MPa, no more than	1,4 (excess.)
HTS conductor temperature, K	65 - 76
Power supply of the cryogenic system is carried out by	50 Hz,
alternating 3-phase current	220/380 V
Power consumption, kW, no more than	300



**Preliminary current tests** of the cable were carried out before connecting the line to the network. The cable was powered by low-voltage direct current source when the current leads at the far end were interconnected. The current increased stepwise from 1.0 kA to 4.5 kA. At the same time, the cable remained in a superconducting state, that mean, the critical current of the cable line was not less than 4.5 kA at 73 K

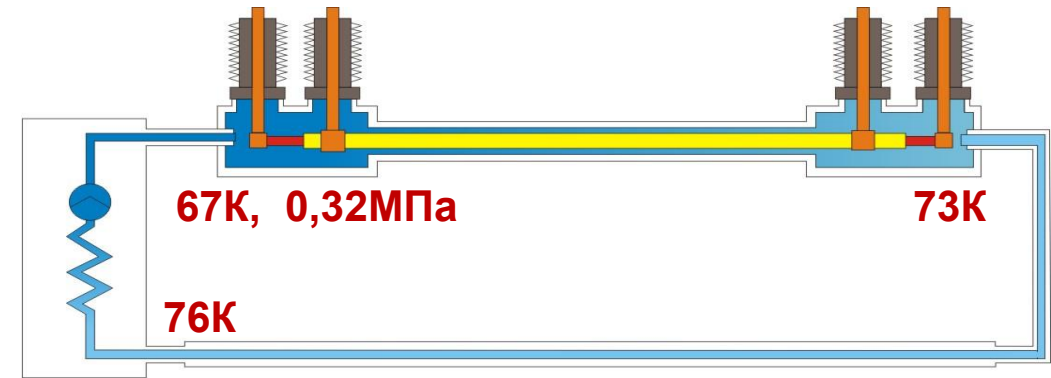

According to slide 11, the expected critical current at 73K is at the level of 4.5 - 5.0 kA

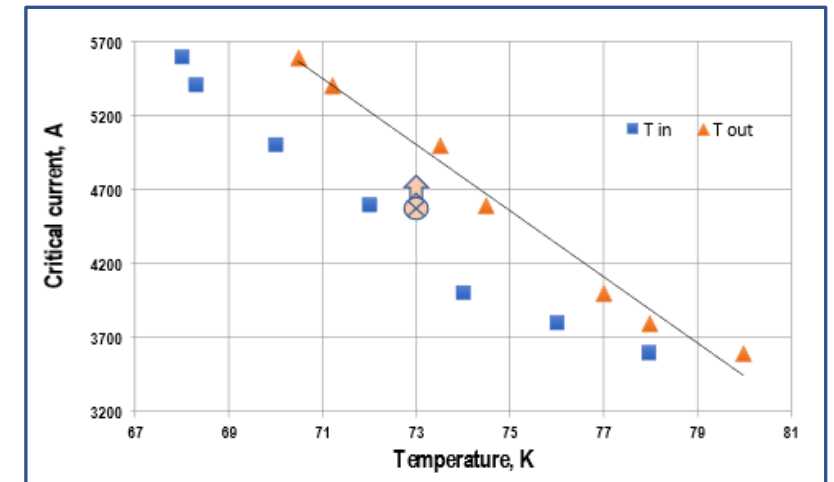
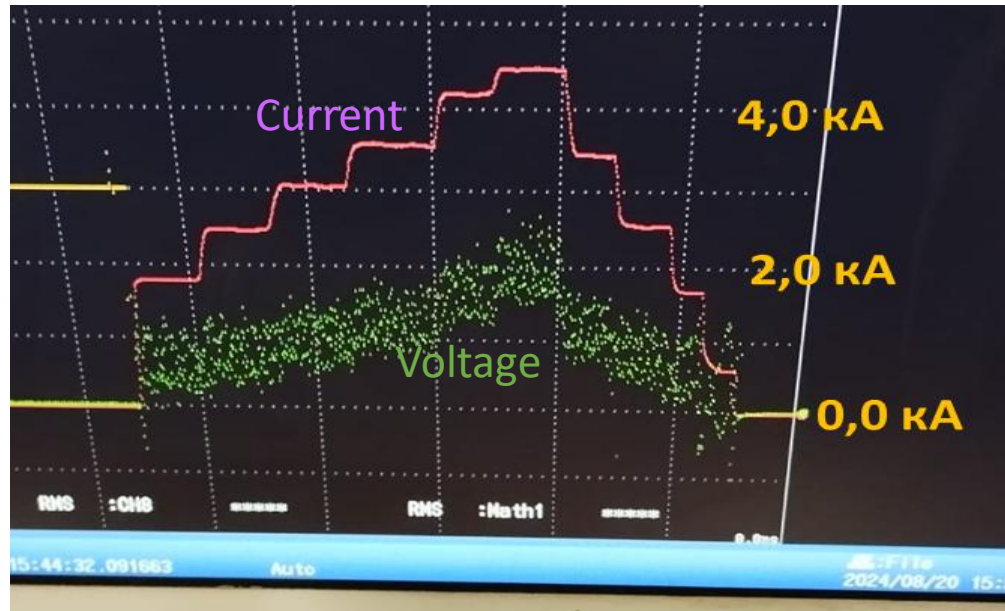

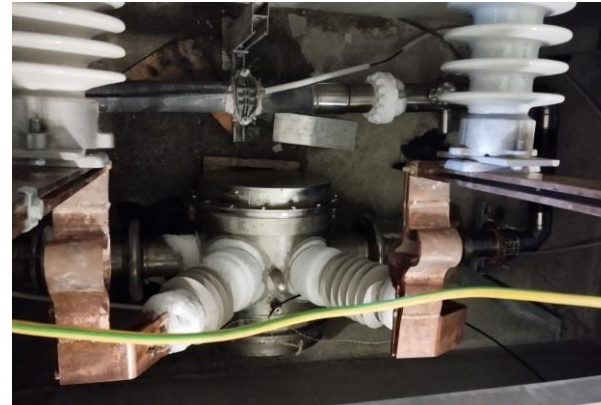

## CHARACTERISTICS OF DC TRANSMISSION DURING ACCEPTANCE TESTS OF THE HTS DC CABLE LINE

Transmission direction	Transmission via HTS cable	Active power	Reactive power	Inverter	Transmission to the grid
From SS "RP 9" to SS "Tsentralnaya"	U= 20 kV I=2496 A	49 MW	26 MVar	Angles: On - 35 Off - 20	$U_f=110\text{kV}$ $I_f= 290 \text{ A}$

The operability of the HTS CL assembled with the cryogenic system and the correctness of the design data of the project have been confirmed. All design characteristics have been achieved. A full range of competencies has been formed for the implementation of projects for the creation of superconducting cable lines.

## Acceptance tests of the HTS DC line

In accordance with the POSSETI current regulatory documents, the new network equipment should be tested over a period of three days under nominal load conditions. HTS cable line was connected to the St. Petersburg power grid in the mode of transmitting rated power from 110 kV "RP-9" substation to 330 kV "Tsentralnaya" substation. The transmission of the rated power lasted for 72 hours. The table on the left showcase the performance characteristics of the transmission. Acceptance tests were successful.

Thus, Implementation of the St. Petersburg pilot project for the creation of a 2.4 km long superconducting DC cable line with a transmitted power of 50 MW and its testing as part of the St. Petersburg power system have been successfully completed.

In 2025, the developed HTS DC cable line with a transmitted power of 50 MW at 20 kV will be put into pilot-scale operation.

*Thank you for your attention*

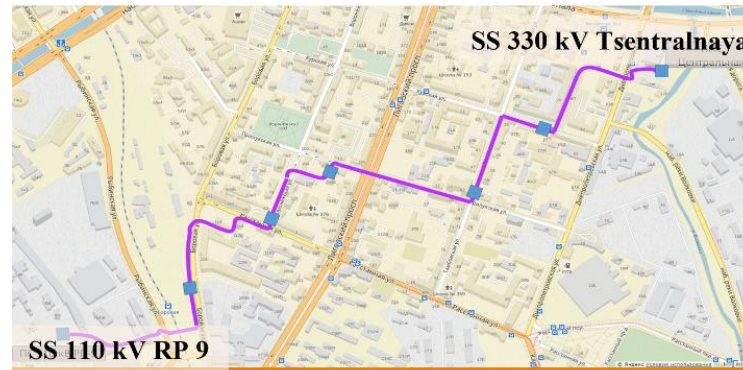

Detailed description in: V. Sytnikov, *et al.*, "The HTS Cable Line Project in St. Petersburg, History and Implementation", *IEEE TAS*, vol. 35, no. 7, Oct. 2025, Art no. 3800809, doi: 10.1109/TASC.2025.3591689.