

HTS cable design and evaluation in YOKOHAMA Project

H. Yumura¹, M. Ohya¹, Y. Ashibe¹, M. Watanabe¹, T. Minamino¹, T. Masuda¹,
S. Honjo², T. Mimura², Y. Kitoh² and Y. Noguchi²

¹Sumitomo Electric Industries, Ltd., 1-1-3 Shimaya, Konohana-ku, Osaka, 554-0024 Japan

²Tokyo Electric Power Company, 4-1 Egasaki-cho, Tsurumi-ku, Yokohama, 230-8510 Japan

E-mail : yumura-hiroyasu@sei.co.jp

Abstract. HTS cable demonstration project supported by Ministry of Economy, Trade and Industry (METI) and New Energy and Industrial Technology Development Organization (NEDO) has started since FY 2007 in Japan. The target of this project is to operate a 66 kV, 200 MVA HTS cable in the live network of Tokyo Electric Power Company (TEPCO) in order to demonstrate its reliability and stable operation. Various preliminary tests with the short core samples were conducted to confirm the HTS cable design. One of the technical targets in this project is to reduce the AC losses of HTS cable cores. For this purpose, a new type DI-BSCCO wire with twisted superconducting filaments which is named TypeAC is applied in the cable core. A short cable core made with TypeAC wires shows its AC loss is 0.8 W/m/ph at 2 kArms, which is about 1/4 of the one with standard DI-BSCCO wires. Another important target is to manage a fault current. At a preliminary test with the short cable cores, it showed that the cable could manage the through-fault of 10 kA at 2 sec and survived at 31.5 kA at 2 sec. As the electric insulation tests, AC 90 kV for 3 hours and lightning impulse at ± 385 kV, 3 shots for each were applied to a cable core, successfully. The results of tensile and bending tests showed the cable core has good mechanical properties. The design of the HTS cable for YOKOHAMA project has been completed as well as those of a termination and a joint. A 30-meter HTS cable was manufactured and a 30-meter HTS cable system was installed in SEI facility. The cable system was cooled down and tested to verify its performance before constructing the HTS cable system in YOKOHAMA. This paper describes the design and test results of the 30-meter HTS cable, and also performance test results of the 30-meter cable system.

1. Introduction

High Temperature Superconducting (HTS) cables can achieve larger power transmission capacity and lower power loss with a compact size. This is effective in reducing the costs of cable system construction and operation. As the environmental features, HTS cables are able to reduce energy consumption because of lower transmission loss. In addition, because HTS cables are cooled with liquid nitrogen that is used as an insulating material, the HTS cables are non-flammable and non-explosive in nature. Moreover, superconducting shield layers led to no leakage of the magnetic fields at the outside of the cable. Therefore, HTS cables don't effect any electro-magnetic influence to their outside. The reliability is one of the most important factors for the power cables which work for a long-term as a component of the infrastructure. The primary factor of degradation in conventional cables is considered to repeated expansion and contraction of the cable itself due to temperature change caused by load fluctuation and/or ambient temperature change throughout a day or a year. On the other hand, HTS cables are operated at the almost constant temperature in liquid nitrogen so that they are not expected to have any damage due to thermo-mechanical motion during their operation.

Due to these advantages, several HTS cable demonstration projects for commercialization have been undertaken around the world [1][2][3][4][5].

In Japan, a new HTS cable project, (YOKOHAMA Project) supported by Ministry of Economy, Trade and Industry and New Energy and Industrial Technology Development Organization started in 2007. This project is the Japanese first HTS cable demonstration project in live grid [6].

2. Outline of Yokohama Project

The target of this project is to operate a 66kV, 200MVA HTS cable in the live power network in order to demonstrate its reliability and stable operation. Tokyo Electric Power Company (TEPCO) provides the real grid and studies the impacts of connecting the HTS cable to the existing conventional facilities. Sumitomo Electric Industries, Ltd. (SEI) designs and manufactures the HTS cable, terminations and a joint. Mayekawa Mfg. Co., Ltd. develops and provides a cooling system.

A demonstration site has been decided to ASAHI substation which is located in YOKOHAMA, Kanagawa prefecture. In this substation, a HTS cable system will be installed and connected to a 66 kV bus-line. A 66 kV line is the major transmission one in TEPCO's power network.

Other system components such as a monitoring system, an alarm system and a switching system will be also built and customized to operate the HTS cable system. The project team will perform the failure mode analysis, studies of the network protection and alarm method of the HTS cable system. The influences of the fault current and the surge voltage to the HTS cable have been already studied and considered to the HTS cable specifications [6].

The specifications of a HTS cable system installed in Asahi substation and the final targets in this project are shown in Table 1. The schematic configuration of the demonstration system in Asahi substation is shown in Figure 1. The HTS cable has a compact 3-in-One cable structure to install into a 150 mm conduit and the total cable length is expected to be between 200 and 300-meters depending on the detailed site configuration. The rated voltage, current and transmission capacity are 66 kV, 1.75 kA_{rms} and 200 MVA, respectively. The HTS cable cores shall have lower AC loss property which is less than 1 W/m/core at 2 kA_{rms}. And also, the HTS cable has to manage the through fault up to 10 kA_{rms} for 2 sec and survive at the maximum fault current of 31.5 kA_{rms} for 2 sec. Two HTS cables are installed along the layout and connected each other in a joint. The HTS cable system is connected to the conventional 66 kV power cables at the both terminations. In the normal mode, a 66kV bus-line is connected with the HTS cable system. If any issues will be happened in the HTS cable system, a 66kV bus-line is switched to connect with the bypass line.

The final targets in this project are to develop a 66 kV, 3 kA_{rms} and 340 MVA class HTS cable with lower AC loss which is less than 1 W/m/core at 3 kA_{rms}, 3 kA_{rms}-class cable-to-cable joint and termination. They are being demonstrated on the short samples by the end of fiscal 2012.

Table 1. Specifications of HTS cable system for Asahi substation and final target in this project

Items	Specifications of HTS cable system	Final targets in the project (2012)
Cable structure	Three cores-in-one cryostat ("3-in-One")	←
Rated voltage, current, capacity	66 kV, 1.75 kA _{rms} , 200 MVA	66kV, 3 kA _{rms} , 340 MVA
Total cable length	200 ~ 300 m	Demonstrated by short sample
AC loss of core	less than 1 W/m/core at 2kA _{rms}	less than 1 W/m/core at 3 kA _{rms}
Accessories	Cable termination boxes (both ends) Cable-to-cable joint	3kA _{rms} -class termination 3kA _{rms} -class cable-to-cable joint
Laying condition	150 mm conduit, details are TBD	To install into 150 mm conduit
Fault current condition	Maximum through fault :10 kA _{rms} -2 sec Maximum fault current :31.5 kA _{rms} -2 sec	Maximum : 31.5 kA _{rms} -2 sec

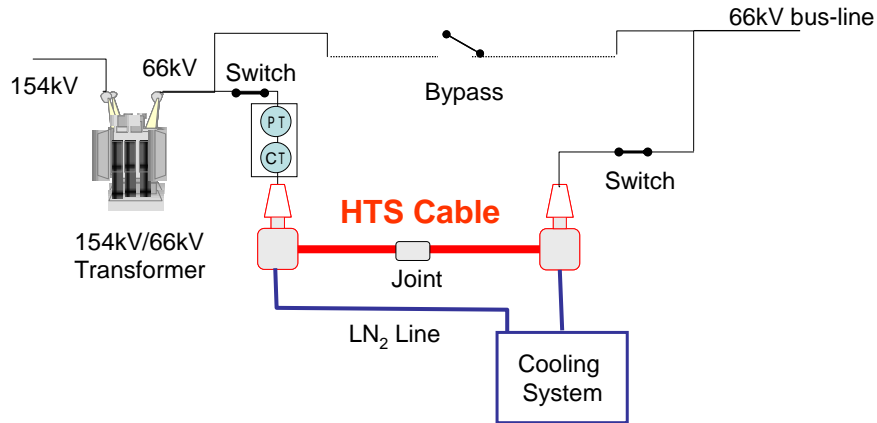

Figure 1. Schematic configuration of the demonstration system in ASAHI substation.

The total project period is planned to be 6 years. The project schedule is shown in Table 2. In the fiscal 2007 and 2008, the components of HTS cable system such as HTS cable, joint and termination were designed and tested to be confirmed their design. In the fiscal 2009, the pre-system with a 30-meter HTS cable has been installed in SEI facility to demonstrate the basic performance of the HTS cable and its accessories. Then the manufacture of the actual HTS cable to install in Asahi substation will be started in 2009 and completed in 2010. The HTS cable system will be installed in Asahi substation and energized in 2011. The long-term operation in the live grid is scheduled for one year through 2012.

Table 2. Schedule of YOKOHAMA Project

	FY 2007	FY 2008	FY 2009	FY 2010	FY 2011	FY 2012
Cable system development	Design - Cable, Joint, Termination Preliminary tests - AC loss, Fault current test, Mechanical test, etc.		Pre-performance test with 30m cable system			
Field test	Analysis of the grid condition		Cable manufacturing Cooling system manufacturing	Install	Long term test	

3. Preliminary tests results

The various preliminary tests and studies were conducted to design a HTS cable, a joint and termination [6][7]. The results of various preliminary tests and studies for the cable design are summarized in Table 3.

The combined core design with two types of DI-BSCCO, typeACT and TypeHT, showed good electrical and mechanical properties. It achieved the larger current capacity of 3 kA_{rms} and lower AC loss property of 0.8 W/m/core at 2 kA_{rms}. The results of electrical insulation tests for the core sample with dielectric thickness of 6 mm showed good performance and satisfied the required specifications. The cable core could manage the through fault of 10 kA_{rms} for 2 sec and survive at 31.5 kA_{rms} for 2 sec. The 3-cores sample had no damage in the condition of up to 0.6 % tensile strain in liquid nitrogen and 0.3 % compressive strain at ambient temperature, and also at several heat-cycles. The tensile forces caused by 0.3 % heat contraction of the 3-cores was approximately 2,500 kgf. The 3-cores sample had no damage at bending test with the bending diameter of 2.4-meter. According to these preliminary tests, it was confirmed that the cable has been designed to meet the required specifications.

Table 3. Summary of various preliminary test results for the cable design

Items		Required specifications at Asahi-substation	Results
Cable structure		3-in-One HTS cable	Design : complete
Electrical properties	Current	Rated : 1.75 kA _{rms} (maximum : 2.5 kA _{rms})	Confirmed up to 3 kA _{rms}
	AC loss	< 1W/m/core at 2 kA _{rms}	0.8 W/m/core at 2 kA _{rms}
	Electrical insulation	Rated : 66 kV (phase-to-phase) Test voltage : AC 90 kV to the ground / 3 hrs : Imp ± 385 kV, 3 shots / each	AC 90 kV/ 3 hrs : good Imp ± 385 kV : good DC 152 kV / 10 min : good
	Fault current	To survive at 31.5kA _{rms} - 2sec To manage the through-fault of 10kA _{rms} - 2sec	Survived at 31.5 kA _{rms} – 2 sec Managed the through fault
Mechanical properties	Thermo-mechanical	No damage at heat-contraction of 0.3 % caused by cool-down and also by heat-cycles	No damage at up to 0.6 % tensile strain, 0.3 % compressive strain and also at heat cycles
	Bending	No damage at bending diameter of 18 D (D: cable outer diameter)	No damage at bending diameter of 2.4 m (16.7D)

4. 30-meter HTS cable

A 30-meter HTS cable was designed based on the results of various preliminary tests and manufactured under the condition which had been confirmed by the trial manufacture.

4.1. HTS cable design

The HTS cable has a 3-in-One cable structure as shown in Figure 2. The specifications of a 30-meter HTS cable are shown in Table 4. The cable has 3-cores which consist of two HTS cores and one dummy core. All cores consist of same copper stranded former, but two HTS cores have the electric insulation of 7 mm thickness and meanwhile, a dummy core has one of 6 mm thickness. According to withstanding voltage test conducted on a short core sample with electric insulation of 6 mm, it was confirmed that the sample passed the test voltage specifications of AC 90 kV for 3 hours and lightning impulse at ±385kV, 3 shots for each, successfully [7]. However, from the viewpoint of experience in long-term energization, the electric insulation for two HTS cores were made choice of 7 mm thickness.

For two HTS cores, to reduce the AC losses, the lower AC loss type of DI-BSCCO named TypeACT wires [8] are used in the 3rd and 4th conductor layer which are applied the higher magnetic fields. The standard DI-BSCCO named TypeHT wires are used in 1st and 2nd conductor layer and 2 shield layers, because they are applied relatively smaller magnetic fields. This core design can achieve both of the lower AC loss property less than 1 W/m/core at 2kA_{rms} and the larger current capacity [7].

To manage the fault current at Asahi substation, the cable cores have the copper stranded former and copper shield which cross-sectional area are 140 mm² and 80 mm², respectively. According to preliminary tests conducted on a short core sample, it was confirmed that this cable core design could manage the through fault of 10 kA for 2sec, and survive at 31.5 kA for 2sec.

**Figure 2.** 30-meter HTS cable structure.

Table 4. Specifications of a 30-meter HTS cable

Item	Specifications	
	Core-A, Core-B	Core-C
Former	Copper stranded with surface insulation (140mm ²)	
HTS conductor	4 layer HTS wires : HT/HT/ACT/ACT Designed Ic : 6100A (dc)	4 layer HTS wires: dummy tapes
Electrical dielectric	PPLP / thickness of 7 mm	PPLP/ thickness of 6 mm
HTS shield	2 layer HTS wires : HT/HT Designed Ic : 7000A (dc)	2 layer HTS wires: dummy tapes
Protection layer for core	Copper tapes (80mm ²), craft tape and fabric tape	
Cable cryostat	Coaxial stainless steel double corrugated pipes	
Outer sheath	polyvinyl chloride, thickness of 3.5 mm	
Cable Outer diameter	144 mm	

4.2. HTS cable manufacture and shipping tests

A 30-meter HTS cable was manufactured under the condition which had been confirmed by trial manufacture. The 30-meter cable wound on a drum is shown in Figure 3.

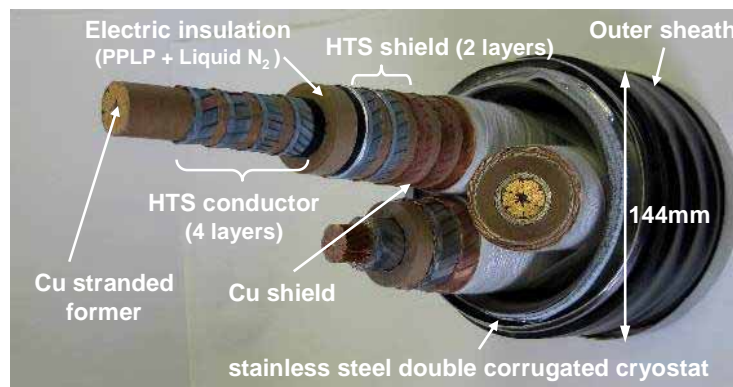
The results of the various shipping tests conducted after the completion of cable manufacture are summarized in Table 5. The I-E characteristics of the HTS conductors and shields, the AC loss test results are shown in Figure 4 and 5, respectively. The measured Ic and AC losses of the cable sample are same values as the designed ones. The results of these tests confirmed that the 30-meter cable demonstrated good properties as designed and satisfied the required specifications.

**Figure 3.** 30-meter HTS cable wound on a drum after manufacture.**Table 5.** Summary of various shipping tests (Sample tests)

Test items	Test conditions and design values	Test results
Critical current measurement (77K, defined by 1 μ V/cm criterion)	Design : 6.1 kA _{dc} (conductor) 7.0 kA _{dc} (shield)	Conductor : 6.1 kA _{dc} (core-1, 2) Shield : 7.1 kA _{dc} (core-1, 2)
AC loss measurement (77K)	Design : 0.8 W/m/core at 2 kA _{rms}	0.83 W/m/core at 2 kA _{rms}
Inductance measurement	Design : 0.12 μ H/m/core	0.12 μ H/m/core
Withstand voltage test (Test condition : 77K, 0.2MPaG)	AC : 90 kV for 3 hours Imp : \pm 385 kV, 3 shots/each DC : 152 kV for 10 minutes	Good, no PD detected Good Good
Cable bending test (bending dia. of 2.4 m (16.7D : D=cable diameter))	To check critical current after test Dismantling inspection after test	No Ic degradation No defect in electrical insulation
Construction test	Dismantling inspection for cable	Same structure and size as designed

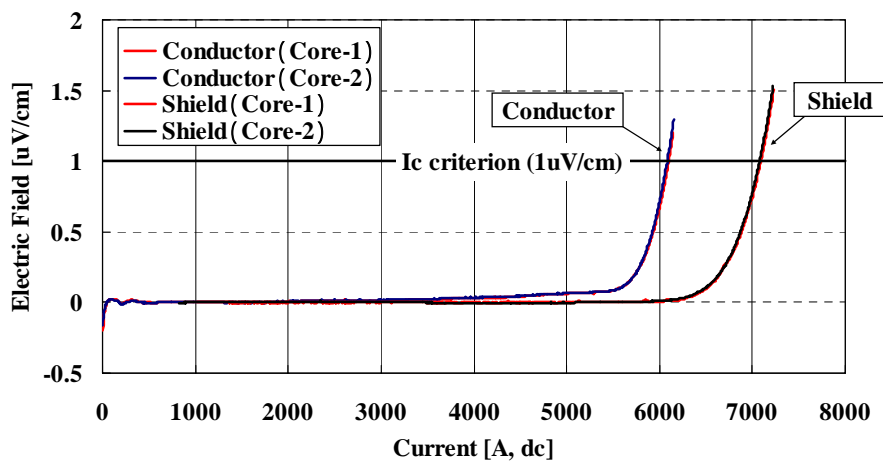

Figure 4. I-E characteristics of HTS conductors and shields for a test sample.

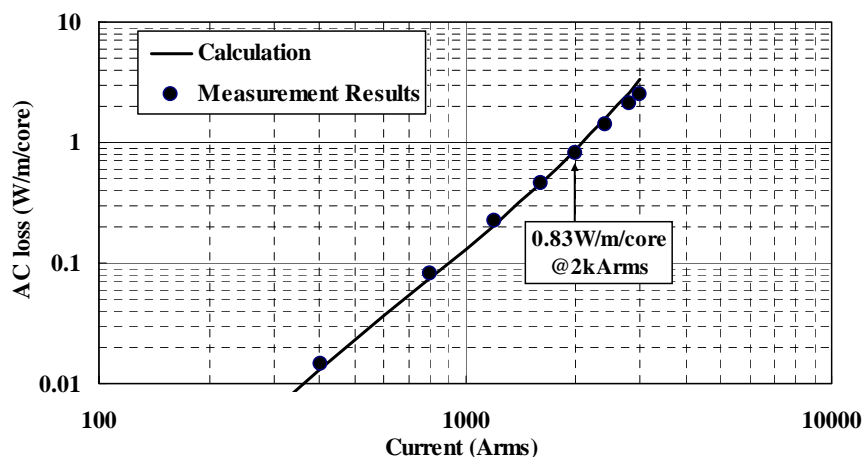

Figure 5. AC loss test results for a test sample.

5. 30-meter HTS cable system installation

The schematic configuration of a 30-meter cable system is shown in Figure 6. It consists of two cable section, a joint, two termination vessels and the cooling system which has the cooling capacity of 1.6 kW at 77 K. The installation layout has a 90 degree bending section with 5-meter radius which consists of 150 mm conduit.

Two HTS cable were installed along the layout, then a cable-to-cable joint and two terminations were assembled. A cable-to-cable joint was assembled in the mock-space of 7-meter vault. After being assembled the terminations, the termination vessels were fixed to the ground. The HTS cable cryostats had been vacuumed and sealed at the factory. So, the vacuum processes at the site were conducted just for the joint case and termination vessels.

After the completion of the HTS cable system installation, the cable system was connected with the cooling system by LN₂ piping. The cover shot of the 30-meter HTS cable system after construction is shown in Figure 7.

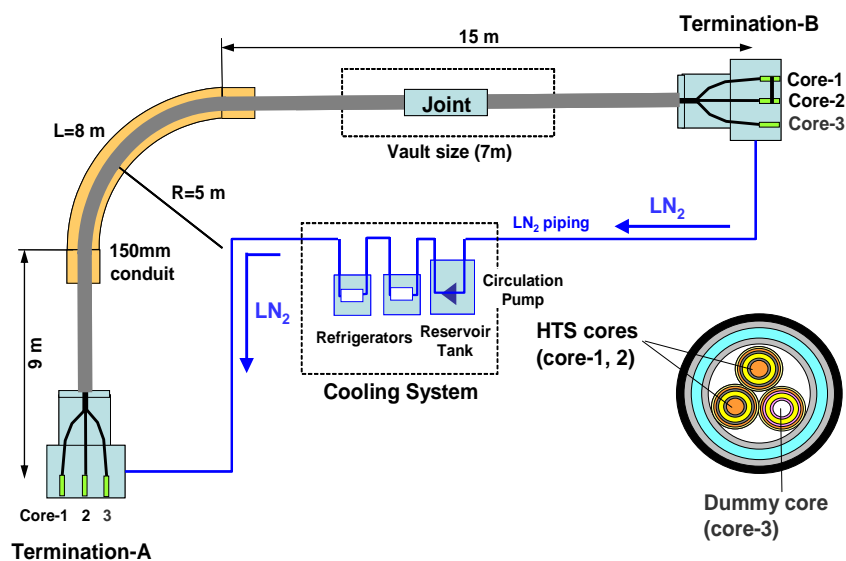

Figure 6. Schematic view of the 30-meter HTS cable system configuration.



Figure 7. Cover shot of the 30-meter HTS cable system.

6. Verification tests on 30-meter HTS cable system

After completion of the 30-meter HTS cable system installation, the verification tests have been conducted to confirm its performance. The verification tests are planned to be conducted by three steps as shown in Table 6. In the 1st cool, the initial performance of the HTS cable such as electric, thermo-mechanical and thermal properties are checked and then the long-term operation test for 30 days is conducted. In the 2nd cool, the cable properties after a heat-cycle are confirmed by the same tests as ones in the 1st cool. In the 3rd cool, the tolerance for current capacity of the HTS cable system is confirmed by the over-current test and the fault current tests are conducted. In addition to these tests, the trial examinations for the troubles of cooling system are conducted in the 3rd cool.

Now, the 1st cool test is going on, the current test results are described as follows.

Table 6. Test items and schedule of the verification tests for 30-meter HTS cable system

Test No.	Test items	Schedule	Detailed test items	
1st cool	Initial test	July – Sept, 2009	Electrical tests	Critical current measurement Shielding current measurement Electrical insulation tests Rated load test (40 kV to the ground, 2 kA _{rms})
			Thermo-mechanical tests	Tension produced during initial cooling Movement of the core-to-core joints by X-ray
			Thermal tests	Heat loss measurement on no load condition Ac loss measurement (2 kA _{rms})
			Long-term operation (30 days)	AC 51 kV to the ground : continuous 2 kA _{rms} loading : 8 hours-ON/16 hours-OFF
2nd cool	Heat-cycle test	Sept – Oct, 2009	To confirm the cable properties after the heat-cycles by electrical, thermo-mechanical and thermal tests.	
3rd cool	Tolerance confirmation test	Nov – Jan, 2010	To confirm the cable properties after the heat-cycles by electrical, thermo-mechanical and thermal tests. Over-current tests (~ 3 kA _{rms}) Fault current tests (~10 kA _{rms}) Trial examination for the troubles of cooling system	

6.1. System withstand pressure test

After the construction of the 30-meter HTS cable system, a withstanding pressure test was conducted under the condition of 0.6 MPaG in accordance to the Japanese high pressure gas safety law. The test results showed no leakage and proved the HTS cable system satisfactory under this test condition.

6.2. Initial cooling test in 1st cool

In the 1st cool, the initial cooling for the HTS cable system was conducted with controlling the temperature in the length-wise direction of the cable, and monitoring the vacuum level in each section, the cable tension. The temperature profiles obtained by an optical fiber in the cable during the initial cooling process are shown in Figure 8. The cable system was cooled gradually for the entire length using nitrogen gas which temperature was -100 degrees Celsius, and then the temperature of nitrogen gas being fed into the cable system was gradually lowered to -150 degrees Celsius. When the temperature gradient for entire length of the cable system had become sufficiently small, liquid nitrogen was injected into the cable system. The entire cable system was cooled to the liquid nitrogen temperature in about 2 days.

After initial cooling process, the tension at the both terminations which produced by the heat contraction of 3-cores was approximately 2,500 kgf. This tension value was same as the assumption from the result of thermo-mechanical test with a short sample. The vacuum level in each section showed no leakage. By X-ray inspection, it was confirmed that the 3-cores inside the joint case didn't move by cooling process.

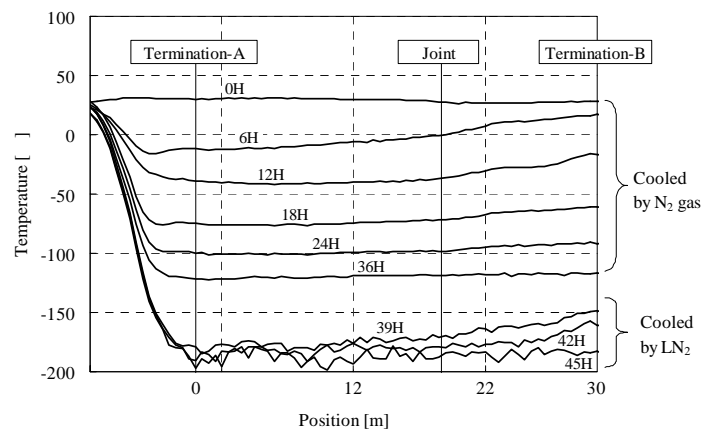
**Figure 8.** Temperature profiles along the cable length in initial cooling process

6.3. Heat loss measurements

The heat invasion into the cable system in no-load condition was measured. The heat loss in the HTS cable section including the joint is approximately 160 W. And the total heat loss in the cable system including the joint, both terminations and LN2 piping are approximately 1.0 kW, which was almost same as the designed value.

The heat loss measurements in the condition of current loading are now on going.

6.4. Critical current measurement

The critical current (I_c) measurements were conducted for the conductors of two HTS cores. The current was loaded to two cores serially and the voltages of the conductors were measured by the voltage taps attached to the top of the current leads. The measured and analyzed I-V characteristics of HTS conductors at 77.4 K are shown in Figure 9. The normal resistive voltage component such as the current leads, connecting sections and so on, was dominant in the measured voltage, because the cable length is relatively short. In consequence, the S/N ratio between the I_c criterion of 1 $\mu\text{V}/\text{cm}$ (= 6.3 mV) and the voltage of estimated normal resistive component (= 210 mV) is just only 3 %. So, the determination of the exact I_c values in these measurements were very difficult. However, on the assumption that the all background voltage components were linear to the current, the I-E characteristics of the HTS conductors at the temperature of 77.4 K, 74.3K and 73.5 K were determined as shown in Figure 10. The I_c values were slightly low compared to the expectation from the results of sample tests, but it was confirmed the cable cores had enough I_c to load the rated current of 2kA_{rms} .

In the 3rd cool, the I_c measurements with the voltage taps which will be attached to the HTS conductors directly are planned to be conducted in order to determine the exact I_c values.

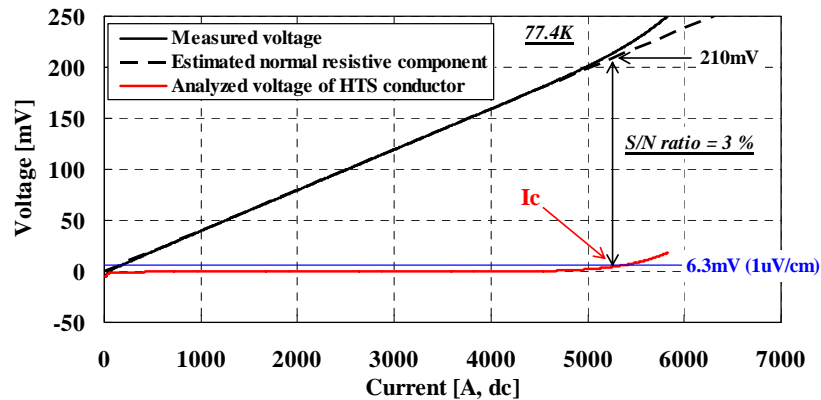

Figure 9. Measured and analyzed I-V characteristic of HTS conductors at 77.4 K.

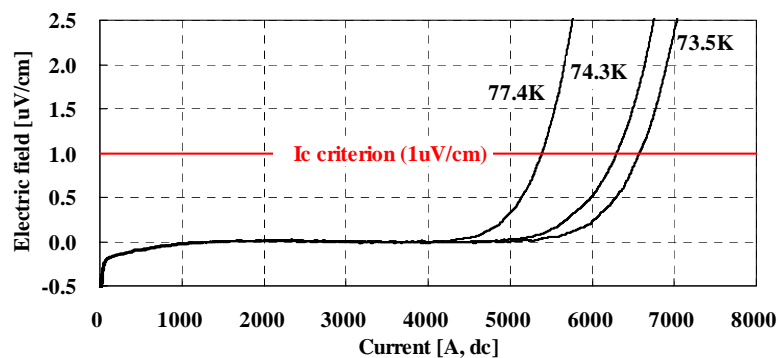

Figure 10. Analyzed I-E characteristic of 30-meter HTS cable conductors.

6.5. AC current loading tests

The AC current loading tests were conducted successfully at the maximum current of $2 \text{ kA}_{\text{rms}}$ for 12 hours. The shielding currents were measured by the Logowski coils attached to the HTS shield connections. The measured shielding current wave-form at the loading current of $2 \text{ kA}_{\text{rms}}$ is shown in Figure 11. The ratio between the shielding current and the loading current was approximately 92 % and the phase-contrast between them was almost 180 degrees.

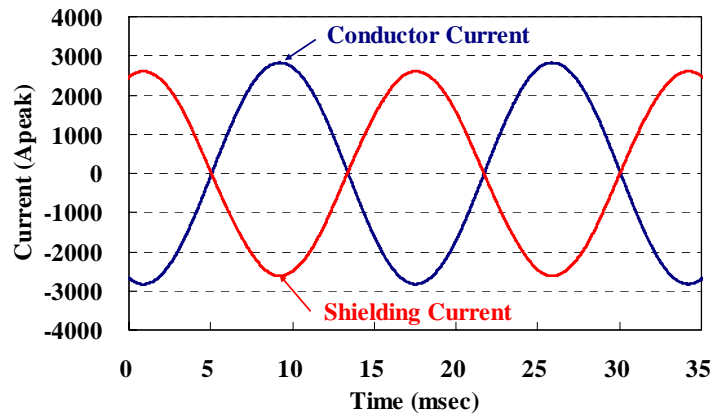

Figure 11. Wave-form of the HTS shielding current at the loading current of $2 \text{ kA}_{\text{rms}}$.

6.6. Withstand voltage tests

As a final test prior to the long-term operation test, the AC withstand voltage test was conducted. This test is equivalent to the withstand voltage test of a 66-kV class cable after site installation. An AC voltage of 76 kV to the ground was applied for 10 minutes, successfully and no PD was observed. In addition to this test, an AC voltage of 42 kV to the ground which is equivalent to the maximum voltage at Asahi substation was applied for 8 hours, successfully and no PD was observed.

6.7. Long-term operation test

After various verification tests, the long-term operation test for 30 days began on August 9th, 2009. An AC voltage of 51 kV to the ground has been applied to all three cores continuously; the current was loaded $2 \text{ kA}_{\text{rms}}$ for 8 hours and 0 A_{rms} for 16 hours per one day during one month. The voltage of 51 kV is equivalent to the accelerated test voltage for 66-kV class cable which demonstrates the 30 years operation in 30 days.

The status of cable inlet and outlet temperature, applied voltage and loaded current during the long-term operation test are shown in Figure 12. The test conditions are the cable outlet temperature of about 77 K and liquid nitrogen pressure of 0.2 MPaG. The long-term operation test has been just completed successfully without any issues on September 7th, 2009.

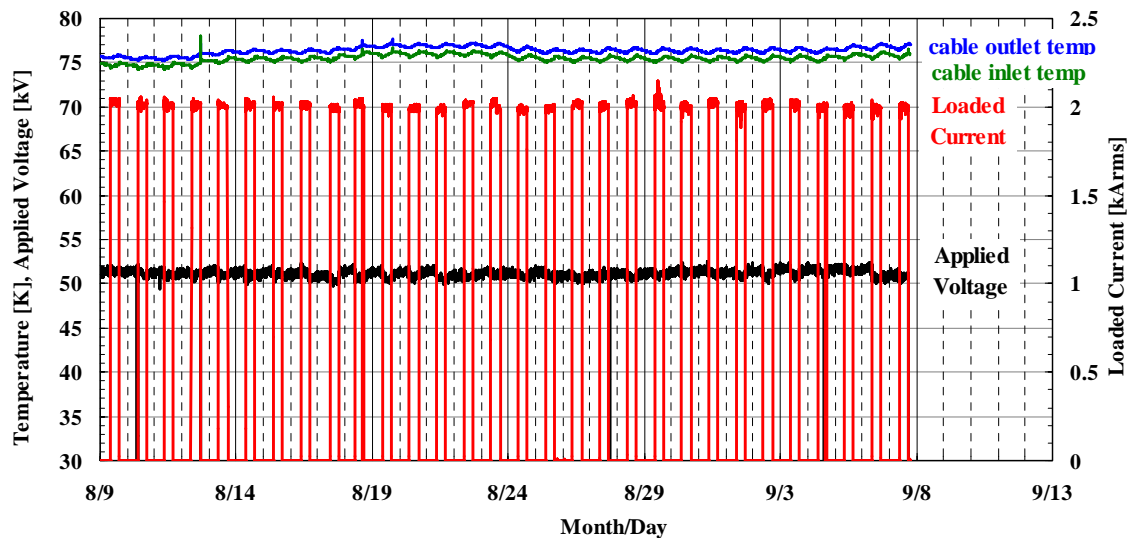

Figure 12. Status of long-term operation test in 1st cool.

7. Conclusion

The design of the HTS cable for YOKOHAMA project has been almost completed as well as those of a termination and a joint. According to their design, a 30-meter HTS cable was manufactured and a 30-meter HTS cable system was installed in SEI facility. The cable system was cooled down and checked the initial properties to verify its performance before constructing the HTS cable system in YOKOHAMA. The verification tests are planned to be three steps (three cooling tests) and now the 1st cooling test is going on. At this point, it has been confirmed that the 30-meter cable system has good properties as designed and the long-term operation test for 30 days has been completed, successfully.

From this time, the heat-cycle test and the tolerance confirmation test are being conducted in the 2nd and 3rd cool for the 30-meter HTS cable system. The HTS cable for Asahi substation will be begun to manufacture in this year by reflecting the various test results of the 30-meter cable system.

Acknowledgments

This work was supported in part by the Japanese Ministry of Economy, Trade and Industry (METI) and the New Energy and Industrial Technology Development Organization (NEDO).

References

- [1] Yumura H, et.al., *SEI Technical Review*, 2009, No.68, pp 69-79
- [2] Maguires J, et.al., *IEEE Trans. Applied Superconductivity*, 2009, Vol.19, No.3, pp 1692-1697
- [3] Lindsay D, et.al., *JICABLE 2007*
- [4] Sytnikov V, et.al., *IEEE Trans. Applied Superconductivity*, 2009, Vol.19, No.3, pp 1702-1705
- [5] Yang H, et.al., *IEEE Trans. Applied Superconductivity*, 2009, Vol.19, No.3, pp 1782-1784
- [6] Yumura H, et.al., *IEEE Trans. Applied Superconductivity*, 2009, Vol.19, No.3, pp 1735-1739
- [7] Masuda T, et.al., *ISS 2008 (21st International Symposium on Superconductivity)*, 2008, to be published
- [8] Ayai N, et.al., *Physica C*, 2008, Vol.468, pp 1747-1752